

**PHILIPPINE BIDDING DOCUMENTS**

**Procurement of  
INFRASTRUCTURE  
PROJECTS**

Government of the Republic of the Philippines

**PROPOSED REHABILITATION OF ELECTRICAL SYSTEM  
AT DEMETRIO TUAZON ELEMENTARY SCHOOL**

**Project number:**

**21-00042**

**Sixth Edition  
July 2020**

# Preface

These Philippine Bidding Documents (PBDs) for the procurement of Infrastructure Projects (hereinafter referred to also as the “Works”) through Competitive Bidding have been prepared by the Government of the Philippines for use by all branches, agencies, departments, bureaus, offices, or instrumentalities of the government, including government-owned and/or -controlled corporations, government financial institutions, state universities and colleges, local government units, and autonomous regional government. The procedures and practices presented in this document have been developed through broad experience, and are for mandatory use in projects that are financed in whole or in part by the Government of the Philippines or any foreign government/foreign or international financing institution in accordance with the provisions of the 2016 revised Implementing Rules and Regulations (IRR) of Republic Act (RA) No. 9184.

The PBDs are intended as a model for admeasurements (unit prices or unit rates in a bill of quantities) types of contract, which are the most common in Works contracting.

The Bidding Documents shall clearly and adequately define, among others: (i) the objectives, scope, and expected outputs and/or results of the proposed contract; (ii) the eligibility requirements of Bidders; (iii) the expected contract duration; and (iv) the obligations, duties, and/or functions of the winning Bidder.

Care should be taken to check the relevance of the provisions of the PBDs against the requirements of the specific Works to be procured. If duplication of a subject is inevitable in other sections of the document prepared by the Procuring Entity, care must be exercised to avoid contradictions between clauses dealing with the same matter.

Moreover, each section is prepared with notes intended only as information for the Procuring Entity or the person drafting the Bidding Documents. They shall not be included in the final documents. The following general directions should be observed when using the documents:

- a. All the documents listed in the Table of Contents are normally required for the procurement of Infrastructure Projects. However, they should be adapted as necessary to the circumstances of the particular Project.
- b. Specific details, such as the “*name of the Procuring Entity*” and “*address for bid submission*,” should be furnished in the Instructions to Bidders, Bid Data Sheet, and Special Conditions of Contract. The final documents should contain neither blank spaces nor options.
- c. This Preface and the footnotes or notes in italics included in the Invitation to Bid, BDS, General Conditions of Contract, Special Conditions of Contract, Specifications, Drawings, and Bill of Quantities are not part of the text of the final document, although they contain instructions that the Procuring Entity should strictly follow.
- d. The cover should be modified as required to identify the Bidding Documents as to the names of the Project, Contract, and Procuring Entity, in addition to date of issue.

- e. Modifications for specific Procurement Project details should be provided in the Special Conditions of Contract as amendments to the Conditions of Contract. For easy completion, whenever reference has to be made to specific clauses in the Bid Data Sheet or Special Conditions of Contract, these terms shall be printed in bold typeface on Sections I (Instructions to Bidders) and III (General Conditions of Contract), respectively.
- f. For guidelines on the use of Bidding Forms and the procurement of Foreign-Assisted Projects, these will be covered by a separate issuance of the Government Procurement Policy Board.

# TABLE OF CONTENTS

<b>Glossary of Terms, Abbreviations, and Acronyms.....</b>	<b>5</b>
<b>Section I. Invitation to Bid .....</b>	<b>8</b>
<b>Section II. Instructions to Bidders.....</b>	<b>9</b>
1. Scope of Bid.....	10
2. Funding Information .....	10
3. Bidding Requirements.....	10
4. Corrupt, Fraudulent, Collusive, Coercive, and Obstructive Practices .....	10
5. Eligible Bidders.....	11
6. Origin of Associated Goods .....	11
7. Subcontracts .....	11
8. Pre-Bid Conference.....	12
9. Clarification and Amendment of Bidding Documents.....	12
10. Documents Comprising the Bid: Eligibility and Technical Components.....	12
11. Documents Comprising the Bid: Financial Component .....	13
12. Alternative Bids .....	13
13. Bid Prices .....	13
14. Bid and Payment Currencies.....	13
15. Bid Security.....	14
16. Sealing and Marking of Bids.....	14
17. Deadline for Submission of Bids .....	14
18. Opening and Preliminary Examination of Bids .....	14
19. Detailed Evaluation and Comparison of Bids.....	14
20. Post Qualification.....	15
21. Signing of the Contract .....	15
<b>Section III. Bid Data Sheet.....</b>	<b>16</b>
<b>Section IV. General Conditions of Contract .....</b>	<b>19</b>
1. Scope of Contract.....	20
2. Sectional Completion of Works.....	20
3. Possession of Site.....	20
4. The Contractor’s Obligations.....	20
5. Performance Security .....	20
6. Site Investigation Reports .....	21

7.	Warranty.....	21
8.	Liability of the Contractor.....	21
9.	Termination for Other Causes.....	21
10.	Dayworks.....	21
11.	Program of Work.....	22
12.	Instructions, Inspections and Audits.....	22
13.	Advance Payment.....	22
14.	Progress Payments.....	22
15.	Operating and Maintenance Manuals.....	22
	<b>Section V. Special Conditions of Contract.....</b>	<b>24</b>
	<b>Section VI. Specifications.....</b>	<b>26</b>
	<b>Section VII. Drawings.....</b>	<b>28</b>
	<b>Section VIII. Bill of Quantities.....</b>	<b>29</b>
	<b>Section IX. Checklist of Technical and Financial Documents.....</b>	<b>31</b>

# *Glossary of Terms, Abbreviations, and Acronyms*

**ABC** – Approved Budget for the Contract.

**ARCC** – Allowable Range of Contract Cost.

**BAC** – Bids and Awards Committee.

**Bid** – A signed offer or proposal to undertake a contract submitted by a bidder in response to and in consonance with the requirements of the bidding documents. Also referred to as *Proposal* and *Tender*. (2016 revised IRR, Section 5[c])

**Bidder** – Refers to a contractor, manufacturer, supplier, distributor and/or consultant who submits a bid in response to the requirements of the Bidding Documents. (2016 revised IRR, Section 5[d])

**Bidding Documents** – The documents issued by the Procuring Entity as the bases for bids, furnishing all information necessary for a prospective bidder to prepare a bid for the Goods, Infrastructure Projects, and/or Consulting Services required by the Procuring Entity. (2016 revised IRR, Section 5[e])

**BIR** – Bureau of Internal Revenue.

**BSP** – Bangko Sentral ng Pilipinas.

**CDA** – Cooperative Development Authority.

**Consulting Services** – Refer to services for Infrastructure Projects and other types of projects or activities of the GOP requiring adequate external technical and professional expertise that are beyond the capability and/or capacity of the GOP to undertake such as, but not limited to: (i) advisory and review services; (ii) pre-investment or feasibility studies; (iii) design; (iv) construction supervision; (v) management and related services; and (vi) other technical services or special studies. (2016 revised IRR, Section 5[i])

**Contract** – Refers to the agreement entered into between the Procuring Entity and the Supplier or Manufacturer or Distributor or Service Provider for procurement of Goods and Services; Contractor for Procurement of Infrastructure Projects; or Consultant or Consulting Firm for Procurement of Consulting Services; as the case may be, as recorded in the Contract Form signed by the parties, including all attachments and appendices thereto and all documents incorporated by reference therein.

**Contractor** – is a natural or juridical entity whose proposal was accepted by the Procuring Entity and to whom the Contract to execute the Work was awarded. Contractor as used in these Bidding Documents may likewise refer to a supplier, distributor, manufacturer, or consultant.

**CPI** – Consumer Price Index.

**DOLE** – Department of Labor and Employment.

**DTI** – Department of Trade and Industry.

**Foreign-funded Procurement or Foreign-Assisted Project** – Refers to procurement whose funding source is from a foreign government, foreign or international financing institution as specified in the Treaty or International or Executive Agreement. (2016 revised IRR, Section 5[b]).

**GFI** – Government Financial Institution.

**GOCC** – Government-owned and/or –controlled corporation.

**Goods** – Refer to all items, supplies, materials and general support services, except Consulting Services and Infrastructure Projects, which may be needed in the transaction of public businesses or in the pursuit of any government undertaking, project or activity, whether in the nature of equipment, furniture, stationery, materials for construction, or personal property of any kind, including non-personal or contractual services such as the repair and maintenance of equipment and furniture, as well as trucking, hauling, janitorial, security, and related or analogous services, as well as procurement of materials and supplies provided by the Procuring Entity for such services. The term “related” or “analogous services” shall include, but is not limited to, lease or purchase of office space, media advertisements, health maintenance services, and other services essential to the operation of the Procuring Entity. (2016 revised IRR, Section 5[r])

**GOP** – Government of the Philippines.

**Infrastructure Projects** – Include the construction, improvement, rehabilitation, demolition, repair, restoration or maintenance of roads and bridges, railways, airports, seaports, communication facilities, civil works components of information technology projects, irrigation, flood control and drainage, water supply, sanitation, sewerage and solid waste management systems, shore protection, energy/power and electrification facilities, national buildings, school buildings, hospital buildings, and other related construction projects of the government. Also referred to as *civil works or works*. (2016 revised IRR, Section 5[u])

**LGUs** – Local Government Units.

**NFCC** – Net Financial Contracting Capacity.

**NGA** – National Government Agency.

**PCAB** – Philippine Contractors Accreditation Board.

**PhilGEPS** - Philippine Government Electronic Procurement System.

**Procurement Project** – refers to a specific or identified procurement covering goods, infrastructure project or consulting services. A Procurement Project shall be described, detailed, and scheduled in the Project Procurement Management Plan prepared by the agency which shall be consolidated in the procuring entity's Annual Procurement Plan. (GPPB Circular No. 06-2019 dated 17 July 2019)

**PSA** – Philippine Statistics Authority.

**SEC** – Securities and Exchange Commission.

**SLCC** – Single Largest Completed Contract.

**UN** – United Nations.



## ***Section I. Invitation to Bid***

### **Notes on the Invitation to Bid**

The Invitation to Bid (IB) provides information that enables potential Bidders to decide whether to participate in the procurement at hand. The IB shall be posted in accordance with Section 21.2 of the 2016 revised IRR of RA No. 9184.

Apart from the essential items listed in the Bidding Documents, the IB should also indicate the following:

- a. The date of availability of the Bidding Documents, which shall be from the time the IB is first advertised/posted until the deadline for the submission and receipt of bids;
- b. The place where the Bidding Documents may be acquired or the website where it may be downloaded;
- c. The deadline for the submission and receipt of bids; and
- d. Any important bid evaluation criteria.

The IB should be incorporated into the Bidding Documents. The information contained in the IB must conform to the Bidding Documents and in particular to the relevant information in the Bid Data Sheet.



**REPUBLIC OF THE PHILIPPINES**  
**QUEZON CITY GOVERNMENT**  
**BIDS AND AWARDS COMMITTEE FOR INFRASTRUCTURE &**  
**CONSULTANCY**



2<sup>nd</sup> floor, Finance Building, Procurement Department, Quezon City Hall Complex, Elliptical Road, Quezon City

May 25, 2021

## Invitation to Bid

No.	Project No.	Project Name	Location	Amount	Duration Cal. Days	Office	Source Fund
<b><u>Buildings – Small B</u></b>							
1	21-00039	Proposed Upgrading of Service Entrance at Payatas B Annex Elementary School	Payatas	1,015,592.29	30	City Engineering Department	Special Education Fund
2	21-00040	Proposed Upgrading of Service Entrance at Carlos P. Garcia High School	E. Rodriguez	1,677,689.20	60	City Engineering Department	Special Education Fund
3	21-00041	Proposed Construction of Vending Site at Mangga Street	Katipunan	2,077,798.42	60	City Engineering Department	Engineering Department
4	21-00042	Proposed Rehabilitation of Electrical System at Demetrio Tuazon Elementary School	Lourdes	2,554,487.62	90	City Engineering Department	Special Education Fund
5	21-00043	Proposed Rehabilitation of Old Barangay Hall at Barangay Libis (Phase 2)	Libis	3,282,450.73	90	City Engineering Department	Engineering Department
6	21-00044	Proposed Construction of Stage at San Francisco Elementary School	Del Monte	3,299,250.05	90	City Engineering Department	Engineering Department-Continuing
7	21-00045	Proposed Rehabilitation of Electrical System at Police Station 5	Fairview	3,330,404.77	90	City Engineering Department	Engineering Department
<b><u>Buildings – Medium A</u></b>							
8	21-00046	Proposed Construction of Sto. Domingo Multi-Purpose Building (Phase 1)	Sto. Domingo	122,645,062.03	420	City Engineering Department	OCM-20% Community Development Fund
<b><u>Buildings – Medium B</u></b>							
9	21-00047	Proposed Construction of Seven (7) Storey Academic Building at QCU Main Campus (Phase 2)	San Bartolome	167,209,016.04	420	City Engineering Department	Trust Fund
10	20-00150B	Proposed Construction of New Kamuning Public Market (Phase 1)	Kamuning	173,882,714.62	510	City Engineering Department	Engineering Department
<b><u>Roads – Small B</u></b>							

11	21-00048	Proposed Rehabilitation (Surface Improvement) of Makabayan Street	Obrero	1,394,478.44	20	City Engineering Department	OCM-20% Community Development Fund
12	21-00049	Proposed Rehabilitation (Surface Improvement) of Parkway Street	Obrero	1,470,652.26	20	City Engineering Department	OCM-20% Community Development Fund
13	21-00050	Proposed Rehabilitation (Surface Improvement) of Rolling Road	Obrero	1,764,985.43	25	City Engineering Department	OCM-20% Community Development Fund
14	21-00051	Proposed Rehabilitation (Surface Improvement) of Mabilis Street	Pinyahan	2,570,503.04	25	City Engineering Department	OCM-20% Community Development Fund
15	21-00052	Proposed Rehabilitation (Surface Improvement) of Dasmariñas Street	Damar	3,056,767.14	20	City Engineering Department	OCM-20% Community Development Fund
16	21-00053	Proposed Rehabilitation of Road and Drainage at Ilang-Ilang Street (St. Andrew Subdivision)	Nagkaisang Nayon	4,217,010.66	90	City Engineering Department	OCM-20% Community Development Fund
17	21-00054	Proposed Rehabilitation (Surface Improvement) of Corumi Street	Masambong	5,754,890.03	40	City Engineering Department	OCM-20% Community Development Fund
18	21-00055	Proposed Rehabilitation of Road and Drainage at Batangas Street	Alicia	6,645,595.96	120	City Engineering Department	OCM-20% Community Development Fund
19	21-00056	Proposed Rehabilitation of Road and Drainage at Actuarial Street	Bahay Toro	8,773,209.77	150	City Engineering Department	OCM-20% Community Development Fund
20	21-00057	Proposed Rehabilitation of Road and Drainage at Linaw Street	Sienna	10,884,632.54	180	City Engineering Department	OCM-20% Community Development Fund
21	21-00058	Proposed Rehabilitation of Road and Drainage at Road 23	Bahay Toro	14,841,163.26	180	City Engineering Department	OCM-20% Community Development Fund
22	21-00059	Proposed Rehabilitation of Road and Drainage at Zamora Street	Paltok	17,526,621.80	180	City Engineering Department	OCM-20% Community Development Fund

1. The **QUEZON CITY LOCAL GOVERNMENT**, through *funding source of various years* intends to apply the sum stated above being the Approved Budget for the Contract (ABC) to payments under the contract *for the above stated Projects*. Bids received in excess of the ABC shall be automatically rejected at bid opening.
2. The **QUEZON CITY LOCAL GOVERNMENT** now invites bids for the above Procurement Project. Completion of the Works is required *as stated above*. Bidders should have completed a contract similar to the Project. The description of an eligible bidder is contained in the Bidding Documents, particularly, in Section II (Instructions to Bidders).
3. Bidding will be conducted through open competitive bidding procedures using non-discretionary "*pass/fail*" criterion as specified in the 2016 revised Implementing Rules and Regulations (IRR) of Republic Act (RA) No. 9184.



10. The *Quezon City Local Government* reserves the right to reject any and all bids, declare a failure of bidding, or not award the contract at any time prior to contract award in accordance with Sections 35.6 and 41 of the 2016 revised Implementing Rules and Regulations (IRR) of RA No. 9184, without thereby incurring any liability to the affected bidder or bidders.
11. For further information, please refer to:

**ATTY. DOMINIC B. GARCIA**  
OIC, Procurement Department  
2<sup>nd</sup> Floor, Procurement Department,  
Finance Building, Quezon City Hall Compound  
Elliptical Road, Barangay Central Diliman, Quezon City.  
Tel. No. (02)8988-4242 loc. 8506/8710  
Email Add: bacinfra.procurement@quezoncity.gov.ph  
Website: [www.quezoncity.gov.ph](http://www.quezoncity.gov.ph)

12. You may visit the following websites:

For downloading of Bidding Documents: <https://quezoncity.gov.ph/public-notices/procurement/>

By:

  
**ATTY. MARK DALE DIAMOND P. PERRAL**  
Chairman BAC-Infra and Consultancy

## ***Section II. Instructions to Bidders***

### **Notes on the Instructions to Bidders**

This Section on the Instruction to Bidders (ITB) provides the information necessary for bidders to prepare responsive bids, in accordance with the requirements of the Procuring Entity. It also provides information on bid submission, eligibility check, opening and evaluation of bids, post-qualification, and on the award of contract.

## 1. Scope of Bid

The Procuring Entity, **Quezon City Government** invites Bids for the **PROPOSED REHABILITATION OF ELECTRICAL SYSTEM AT DEMETRIO TUAZON ELEMENTARY SCHOOL**, with Project Identification Number **21-00042**.

*[Note: The Project Identification Number is assigned by the Procuring Entity based on its own coding scheme and is not the same as the PhilGEPS reference number, which is generated after the posting of the bid opportunity on the PhilGEPS website.]*

The Procurement Project (referred to herein as “Project”) is for the construction of Works, as described in Section VI (Specifications).

## 2. Funding Information

2.1. The GOP through the source of funding as indicated below for **2021** in the amount of **Two Million Five Hundred Fifty-Four Thousand Four Hundred Eighty-Seven Pesos & 62/100 Cts. (P 2,554,487.62)**.

2.2. The source of funding is:

a. LGUs, the Annual or Supplemental Budget, as approved by the Sanggunian.

## 3. Bidding Requirements

The Bidding for the Project shall be governed by all the provisions of RA No. 9184 and its 2016 revised IRR, including its Generic Procurement Manual and associated policies, rules and regulations as the primary source thereof, while the herein clauses shall serve as the secondary source thereof.

Any amendments made to the IRR and other GPPB issuances shall be applicable only to the ongoing posting, advertisement, or invitation to bid by the BAC through the issuance of a supplemental or bid bulletin.

The Bidder, by the act of submitting its Bid, shall be deemed to have inspected the site, determined the general characteristics of the contracted Works and the conditions for this Project, such as the location and the nature of the work; (b) climatic conditions; (c) transportation facilities; (c) nature and condition of the terrain, geological conditions at the site communication facilities, requirements, location and availability of construction aggregates and other materials, labor, water, electric power and access roads; and (d) other factors that may affect the cost, duration and execution or implementation of the contract, project, or work and examine all instructions, forms, terms, and project requirements in the Bidding Documents.

## 4. Corrupt, Fraudulent, Collusive, Coercive, and Obstructive Practices

The Procuring Entity, as well as the Bidders and Contractors, shall observe the highest standard of ethics during the procurement and execution of the contract. They or through an agent shall not engage in corrupt, fraudulent, collusive, coercive, and

obstructive practices defined under Annex “P” of the 2016 revised IRR of RA No. 9184 or other integrity violations in competing for the Project.

## 5. Eligible Bidders

- 5.1. Only Bids of Bidders found to be legally, technically, and financially capable will be evaluated.
- 5.2. The Bidder must have an experience of having completed a Single Largest Completed Contract (SLCC) that is similar to this Project, equivalent to at least fifty percent (50%) of the ABC adjusted, if necessary, by the Bidder to current prices using the PSA’s CPI, except under conditions provided for in Section 23.4.2.4 of the 2016 revised IRR of RA No. 9184.  
  
A contract is considered to be “similar” to the contract to be bid if it has the major categories of work stated in the **BDS**.
- 5.3. For Foreign-funded Procurement, the Procuring Entity and the foreign government/foreign or international financing institution may agree on another track record requirement, as specified in the Bidding Document prepared for this purpose.
- 5.4. The Bidders shall comply with the eligibility criteria under Section 23.4.2 of the 2016 IRR of RA No. 9184.

## 6. Origin of Associated Goods

There is no restriction on the origin of Goods other than those prohibited by a decision of the UN Security Council taken under Chapter VII of the Charter of the UN.

## 7. Subcontracts

- 7.1. The Bidder may subcontract portions of the Project to the extent allowed by the Procuring Entity as stated herein, but in no case more than fifty percent (50%) of the Project.

The Procuring Entity has prescribed that:

- a. **Subcontracting is not allowed.**

- 7.1. *[If Procuring Entity has determined that subcontracting is allowed during the bidding , state:]* The Bidder must submit together with its Bid the documentary requirements of the subcontractor(s) complying with the eligibility criterial stated in **ITB** Clause 5 in accordance with Section 23.4 of the 2016 revised IRR of RA No. 9184 pursuant to Section 23.1 thereof.
- 7.2. *[If subcontracting is allowed during the contract implementation stage, state:]* The Supplier may identify its subcontractor during the contract implementation stage. Subcontractors identified during the bidding may be changed during the implementation of this Contract. Subcontractors must submit the documentary



requirements under Section 23.1 of the 2016 revised IRR of RA No. 9184 and comply with the eligibility criteria specified in **ITB** Clause 5 to the implementing or end-user unit.

- 7.3. Subcontracting of any portion of the Project does not relieve the Contractor of any liability or obligation under the Contract. The Supplier will be responsible for the acts, defaults, and negligence of any subcontractor, its agents, servants, or workmen as fully as if these were the Contractor's own acts, defaults, or negligence, or those of its agents, servants, or workmen.

## **8. Pre-Bid Conference**

The Procuring Entity will hold a pre-bid conference for this Project on the specified date and time and either at its physical address on **June 3, 2021 10:00 A.M. at 2nd Floor, Procurement Department-Bidding Room, Finance Building, Quezon City Hall Compound** and/or we encourage the prospective bidders to join through our **Virtual Conference (ZOOM APP) Meeting ID: 854 9489 0133 Password: 273320**

## **9. Clarification and Amendment of Bidding Documents**

Prospective bidders may request for clarification on and/or interpretation of any part of the Bidding Documents. Such requests must be in writing and received by the Procuring Entity, either at its given address or through electronic mail indicated in the **IB**, at least ten (10) calendar days before the deadline set for the submission and receipt of Bids.

## **10. Documents Comprising the Bid: Eligibility and Technical Components**

- 10.1. The first envelope shall contain the eligibility and technical documents of the Bid as specified in **Section IX. Checklist of Technical and Financial Documents**.
- 10.2. If the eligibility requirements or statements, the bids, and all other documents for submission to the BAC are in foreign language other than English, it must be accompanied by a translation in English, which shall be authenticated by the appropriate Philippine foreign service establishment, post, or the equivalent office having jurisdiction over the foreign bidder's affairs in the Philippines. For Contracting Parties to the Apostille Convention, only the translated documents shall be authenticated through an apostille pursuant to GPPB Resolution No. 13-2019 dated 23 May 2019. The English translation shall govern, for purposes of interpretation of the bid.
- 10.3. A valid PCAB License is required, and in case of joint ventures, a valid special PCAB License, and registration for the type and cost of the contract for this Project. Any additional type of Contractor license or permit shall be indicated in the **BDS**.
- 10.4. A List of Contractor's key personnel (e.g., Project Manager, Project Engineers, Materials Engineers, and Foremen) assigned to the contract to be bid, with their

complete qualification and experience data shall be provided. These key personnel must meet the required minimum years of experience set in the **BDS**.

- 10.5. A List of Contractor's major equipment units, which are owned, leased, and/or under purchase agreements, supported by proof of ownership, certification of availability of equipment from the equipment lessor/vendor for the duration of the project, as the case may be, must meet the minimum requirements for the contract set in the **BDS**.

## **11. Documents Comprising the Bid: Financial Component**

- 11.1. The second bid envelope shall contain the financial documents for the Bid as specified in **Section IX. Checklist of Technical and Financial Documents**.
- 11.2. Any bid exceeding the ABC indicated in paragraph 1 of the **IB** shall not be accepted.
- 11.3. For Foreign-funded procurement, a ceiling may be applied to bid prices provided the conditions are met under Section 31.2 of the 2016 revised IRR of RA No. 9184.

## **12. Alternative Bids**

Bidders shall submit offers that comply with the requirements of the Bidding Documents, including the basic technical design as indicated in the drawings and specifications. Unless there is a value engineering clause in the **BDS**, alternative Bids shall not be accepted.

## **13. Bid Prices**

All bid prices for the given scope of work in the Project as awarded shall be considered as fixed prices, and therefore not subject to price escalation during contract implementation, except under extraordinary circumstances as determined by the NEDA and approved by the GPPB pursuant to the revised Guidelines for Contract Price Escalation guidelines.

## **14. Bid and Payment Currencies**

- 14.1. Bid prices may be quoted in the local currency or tradeable currency accepted by the BSP at the discretion of the Bidder. However, for purposes of bid evaluation, Bids denominated in foreign currencies shall be converted to Philippine currency based on the exchange rate as published in the BSP reference rate bulletin on the day of the bid opening.
- 14.2. *Payment of the contract price shall be made in:*
  - a. Philippine Pesos.

## **15. Bid Security**

- 15.1. The Bidder shall submit a Bid Securing Declaration or any form of Bid Security in the amount indicated in the **BDS**, which shall be not less than the percentage of the ABC in accordance with the schedule in the **BDS**.
- 15.2. The Bid and bid security **in no case shall exceed One Hundred Twenty (120) calendar days from the date of opening of bids, unless duly extended by the bidder upon the request of the Head of the Procuring Entity (HoPE) of the Quezon City Local Government**. Any bid not accompanied by an acceptable bid security shall be rejected by the Procuring Entity as non-responsive.

## **16. Sealing and Marking of Bids**

Each Bidder shall submit one copy of the first and second components of its Bid.

The Procuring Entity may request additional hard copies and/or electronic copies of the Bid. However, failure of the Bidders to comply with the said request shall not be a ground for disqualification.

If the Procuring Entity allows the submission of bids through online submission to the given website or any other electronic means, the Bidder shall submit an electronic copy of its Bid, which must be digitally signed. An electronic copy that cannot be opened or is corrupted shall be considered non-responsive and, thus, automatically disqualified.

## **17. Deadline for Submission of Bids**

The Bidders shall submit on the specified date and time and either at its physical address or through online submission as indicated in paragraph 5 of the **IB**.

## **18. Opening and Preliminary Examination of Bids**

- 18.1. The BAC shall open the Bids in public at the time, on the date, and at the place specified in paragraph 9 of the **IB**. The Bidders' representatives who are present shall sign a register evidencing their attendance. In case videoconferencing, webcasting or other similar technologies will be used, attendance of participants shall likewise be recorded by the BAC Secretariat.

In case the Bids cannot be opened as scheduled due to justifiable reasons, the rescheduling requirements under Section 29 of the 2016 revised IRR of RA No. 9184 shall prevail.

- 18.2. The preliminary examination of Bids shall be governed by Section 30 of the 2016 revised IRR of RA No. 9184.

## **19. Detailed Evaluation and Comparison of Bids**

- 19.1. The Procuring Entity's BAC shall immediately conduct a detailed evaluation of all Bids rated "*passed*" using non-discretionary pass/fail criteria. The BAC

shall consider the conditions in the evaluation of Bids under Section 32.2 of 2016 revised IRR of RA No. 9184.

- 19.2. If the Project allows partial bids, all Bids and combinations of Bids as indicated in the **BDS** shall be received by the same deadline and opened and evaluated simultaneously so as to determine the Bid or combination of Bids offering the lowest calculated cost to the Procuring Entity. Bid Security as required by **ITB** Clause 15 shall be submitted for each contract (lot) separately.
- 19.3. In all cases, the NFCC computation pursuant to Section 23.4.2.6 of the 2016 revised IRR of RA No. 9184 must be sufficient for the total of the ABCs for all the lots participated in by the prospective Bidder.

## **20. Post Qualification**

Within a non-extendible period of five (5) calendar days from receipt by the Bidder of the notice from the BAC that it submitted the Lowest Calculated Bid, the Bidder shall submit its latest income and business tax returns filed and paid through the BIR Electronic Filing and Payment System (eFPS), and other appropriate licenses and permits required by law and stated in the **BDS**.

## **21. Signing of the Contract**

The documents required in Section 37.2 of the 2016 revised IRR of RA No. 9184 shall form part of the Contract. Additional Contract documents are indicated in the **BDS**.

## ***Section III. Bid Data Sheet***

### **Notes on the Bid Data Sheet (BDS)**

The Bid Data Sheet (BDS) consists of provisions that supplement, amend, or specify in detail, information, or requirements included in the ITB found in Section II, which are specific to each procurement.

This Section is intended to assist the Procuring Entity in providing the specific information in relation to corresponding clauses in the ITB and has to be prepared for each specific procurement.

The Procuring Entity should specify in the BDS information and requirements specific to the circumstances of the Procuring Entity, the processing of the procurement, and the bid evaluation criteria that will apply to the Bids. In preparing the BDS, the following aspects should be checked:

- a. Information that specifies and complements provisions of the ITB must be incorporated.
- b. Amendments and/or supplements, if any, to provisions of the ITB as necessitated by the circumstances of the specific procurement, must also be incorporated.

# Bid Data Sheet

ITB Clause																																	
5.2	For this purpose, similar contracts shall refer to contracts which have the same major categories of work.																																
7.1	<b>Subcontracting is not allowed.</b>																																
10.3	<p><i>No additional contractor license or permit is required</i></p> <p><b><i>In addition, eligible bidders shall qualify or comply with the following:</i></b></p> <p>1. Bidders with valid Philippine Contractors Accreditation Board (PCAB)</p> <p style="padding-left: 40px;">Type</p> <p style="text-align: center;"><b>Buildings - Small B</b></p>																																
10.4	<p>The minimum work experience requirements for key personnel are the following:</p> <table border="1" style="width: 100%; border-collapse: collapse; margin-top: 10px;"> <thead> <tr> <th style="text-align: center;">Qty.</th> <th style="text-align: center;">Key Personnel</th> <th style="text-align: center;">General Experience</th> <th style="text-align: center;">Relevant Experience</th> </tr> </thead> <tbody> <tr> <td style="text-align: center;">1</td> <td>Project Engineer</td> <td style="text-align: center;">3 years</td> <td style="text-align: center;">3 years</td> </tr> <tr> <td style="text-align: center;">1</td> <td>DPWH duly accredited Materials Engineer</td> <td style="text-align: center;">3 years</td> <td style="text-align: center;">3 years</td> </tr> <tr> <td style="text-align: center;">1</td> <td>Safety Officer</td> <td style="text-align: center;">3 years</td> <td style="text-align: center;">3 years</td> </tr> <tr> <td style="text-align: center;">1</td> <td>Foreman</td> <td style="text-align: center;">3 years</td> <td style="text-align: center;">3 years</td> </tr> <tr> <td style="text-align: center;">2</td> <td>Skilled Worker</td> <td style="text-align: center;">3 years</td> <td style="text-align: center;">3 years</td> </tr> <tr> <td style="text-align: center;">1</td> <td>Driver</td> <td style="text-align: center;">3 years</td> <td style="text-align: center;">3 years</td> </tr> <tr> <td style="text-align: center;">4</td> <td>Laborer/Helper</td> <td style="text-align: center;">1 year</td> <td style="text-align: center;">3 months</td> </tr> </tbody> </table> <p><b><i>In addition, the bidder must execute an affidavit of undertaking duly notarized stating that the foregoing personnel shall perform work exclusively for the project until its completion. Please see attached bid forms.</i></b></p>	Qty.	Key Personnel	General Experience	Relevant Experience	1	Project Engineer	3 years	3 years	1	DPWH duly accredited Materials Engineer	3 years	3 years	1	Safety Officer	3 years	3 years	1	Foreman	3 years	3 years	2	Skilled Worker	3 years	3 years	1	Driver	3 years	3 years	4	Laborer/Helper	1 year	3 months
Qty.	Key Personnel	General Experience	Relevant Experience																														
1	Project Engineer	3 years	3 years																														
1	DPWH duly accredited Materials Engineer	3 years	3 years																														
1	Safety Officer	3 years	3 years																														
1	Foreman	3 years	3 years																														
2	Skilled Worker	3 years	3 years																														
1	Driver	3 years	3 years																														
4	Laborer/Helper	1 year	3 months																														
10.5	<p>The minimum major equipment requirements are the following:</p> <table border="1" style="width: 100%; border-collapse: collapse; margin-top: 10px;"> <thead> <tr> <th style="text-align: left;">Equipment</th> <th style="text-align: center;">Capacity</th> <th style="text-align: center;">Number of Units</th> </tr> </thead> <tbody> <tr> <td>Elf Truck</td> <td></td> <td style="text-align: center;">1</td> </tr> <tr> <td>Scaffolding</td> <td></td> <td style="text-align: center;">as needed</td> </tr> <tr> <td>Power Tools</td> <td></td> <td style="text-align: center;">as needed</td> </tr> <tr> <td>Minor Tools</td> <td></td> <td style="text-align: center;">as needed</td> </tr> </tbody> </table> <p><b><i>In addition, the bidder must execute an affidavit of undertaking duly notarized stating that the foregoing equipment shall be used exclusively for the project until its completion. Please see attached bid forms.</i></b></p>	Equipment	Capacity	Number of Units	Elf Truck		1	Scaffolding		as needed	Power Tools		as needed	Minor Tools		as needed																	
Equipment	Capacity	Number of Units																															
Elf Truck		1																															
Scaffolding		as needed																															
Power Tools		as needed																															
Minor Tools		as needed																															

12	<i>[Insert Value Engineering clause if allowed.]</i>
15.1	<p>The bid security shall be in the form of a Bid Securing Declaration with project number, or any of the following forms and amounts:</p> <p>a) The amount of not less than Php 51,089.75 or equivalent to two percent (2%) of ABC if bid security is in cash, cashier's/manager's check, bank draft/guarantee or irrevocable letter of credit; or</p> <p>b) The amount of not less than Php 127,724.38 or equivalent to five percent (5%) of ABC if bid security is in Surety Bond.</p>
19.2	<b>Partial bid is not allowed.</b> The infrastructure project is packaged in a single lot and the lot shall not be divided into sub-lots for the purpose of bidding, evaluation, and contract award.
20	No additional requirement.
21	<p><b>Additional Contract Documents relevant to the Project as required:</b></p> <ol style="list-style-type: none"> <li><b>1. Construction Schedule and S-curve,</b></li> <li><b>2. Manpower Schedule,</b></li> <li><b>3. Construction Methods,</b></li> <li><b>4. Equipment Utilization Schedule,</b></li> <li><b>5. PERT/CPM or other acceptable tools of project scheduling, shall be included in the submission of Technical Proposal.</b></li> </ol>

## ***Section IV. General Conditions of Contract***

### **Notes on the General Conditions of Contract**

The General Conditions of Contract (GCC) in this Section, read in conjunction with the Special Conditions of Contract in Section V and other documents listed therein, should be a complete document expressing all the rights and obligations of the parties.

Matters governing performance of the Contractor, payments under the contract, or matters affecting the risks, rights, and obligations of the parties under the contract are included in the GCC and Special Conditions of Contract.

Any complementary information, which may be needed, shall be introduced only through the Special Conditions of Contract.



## 1. **Scope of Contract**

This Contract shall include all such items, although not specifically mentioned, that can be reasonably inferred as being required for its completion as if such items were expressly mentioned herein. All the provisions of RA No. 9184 and its 2016 revised IRR, including the Generic Procurement Manual, and associated issuances, constitute the primary source for the terms and conditions of the Contract, and thus, applicable in contract implementation. Herein clauses shall serve as the secondary source for the terms and conditions of the Contract.

This is without prejudice to Sections 74.1 and 74.2 of the 2016 revised IRR of RA No. 9184 allowing the GPPB to amend the IRR, which shall be applied to all procurement activities, the advertisement, posting, or invitation of which were issued after the effectivity of the said amendment.

## 2. **Sectional Completion of Works**

If sectional completion is specified in the **Special Conditions of Contract (SCC)**, references in the Conditions of Contract to the Works, the Completion Date, and the Intended Completion Date shall apply to any Section of the Works (other than references to the Completion Date and Intended Completion Date for the whole of the Works).

## 3. **Possession of Site**

3.1 The Procuring Entity shall give possession of all or parts of the Site to the Contractor based on the schedule of delivery indicated in the **SCC**, which corresponds to the execution of the Works. If the Contractor suffers delay or incurs cost from failure on the part of the Procuring Entity to give possession in accordance with the terms of this clause, the Procuring Entity's Representative shall give the Contractor a Contract Time Extension and certify such sum as fair to cover the cost incurred, which sum shall be paid by Procuring Entity.

3.2 If possession of a portion is not given by the above date, the Procuring Entity will be deemed to have delayed the start of the relevant activities. The resulting adjustments in contract time to address such delay may be addressed through contract extension provided under Annex "E" of the 2016 revised IRR of RA No. 9184.

## 4. **The Contractor's Obligations**

The Contractor shall employ the key personnel named in the Schedule of Key Personnel indicating their designation, in accordance with **ITB** Clause 10.3 and specified in the **BDS**, to carry out the supervision of the Works.

The Procuring Entity will approve any proposed replacement of key personnel only if their relevant qualifications and abilities are equal to or better than those of the personnel listed in the Schedule.

## 5. **Performance Security**

- 5.1. Within ten (10) calendar days from receipt of the Notice of Award from the Procuring Entity but in no case later than the signing of the contract by both parties, the successful Bidder shall furnish the performance security in any of the forms prescribed in Section 39 of the 2016 revised IRR.
- 5.2. The Contractor, by entering into the Contract with the Procuring Entity, acknowledges the right of the Procuring Entity to institute action pursuant to RA No. 3688 against any subcontractor be they an individual, firm, partnership, corporation, or association supplying the Contractor with labor, materials and/or equipment for the performance of this Contract.

## **6. Site Investigation Reports**

The Contractor, in preparing the Bid, shall rely on any Site Investigation Reports referred to in the SCC supplemented by any information obtained by the Contractor.

## **7. Warranty**

- 7.1. In case the Contractor fails to undertake the repair works under Section 62.2.2 of the 2016 revised IRR, the Procuring Entity shall forfeit its performance security, subject its property(ies) to attachment or garnishment proceedings, and perpetually disqualify it from participating in any public bidding. All payables of the GOP in his favor shall be offset to recover the costs.
- 7.2. The warranty against Structural Defects/Failures, except that occasioned-on force majeure, shall cover the period from the date of issuance of the Certificate of Final Acceptance by the Procuring Entity. Specific duration of the warranty is found in the SCC.

## **8. Liability of the Contractor**

Subject to additional provisions, if any, set forth in the SCC, the Contractor's liability under this Contract shall be as provided by the laws of the Republic of the Philippines.

If the Contractor is a joint venture, all partners to the joint venture shall be jointly and severally liable to the Procuring Entity.

## **9. Termination for Other Causes**

Contract termination shall be initiated in case it is determined *prima facie* by the Procuring Entity that the Contractor has engaged, before, or during the implementation of the contract, in unlawful deeds and behaviors relative to contract acquisition and implementation, such as, but not limited to corrupt, fraudulent, collusive, coercive, and obstructive practices as stated in ITB Clause 4.

## **10. Dayworks**

Subject to the guidelines on Variation Order in Annex “E” of the 2016 revised IRR of RA No. 9184, and if applicable as indicated in the **SCC**, the Dayworks rates in the Contractor’s Bid shall be used for small additional amounts of work only when the Procuring Entity’s Representative has given written instructions in advance for additional work to be paid for in that way.

## **11. Program of Work**

11.1. The Contractor shall submit to the Procuring Entity’s Representative for approval the said Program of Work showing the general methods, arrangements, order, and timing for all the activities in the Works. The submissions of the Program of Work are indicated in the **SCC**.

11.2. The Contractor shall submit to the Procuring Entity’s Representative for approval an updated Program of Work at intervals no longer than the period stated in the **SCC**. If the Contractor does not submit an updated Program of Work within this period, the Procuring Entity’s Representative may withhold the amount stated in the **SCC** from the next payment certificate and continue to withhold this amount until the next payment after the date on which the overdue Program of Work has been submitted.

## **12. Instructions, Inspections and Audits**

The Contractor shall permit the GOP or the Procuring Entity to inspect the Contractor’s accounts and records relating to the performance of the Contractor and to have them audited by auditors of the GOP or the Procuring Entity, as may be required.

## **13. Advance Payment**

The Procuring Entity shall, upon a written request of the Contractor which shall be submitted as a Contract document, make an advance payment to the Contractor in an amount not exceeding fifteen percent (15%) of the total contract price, to be made in lump sum, or at the most two installments according to a schedule specified in the **SCC**, subject to the requirements in Annex “E” of the 2016 revised IRR of RA No. 9184.

## **14. Progress Payments**

The Contractor may submit a request for payment for Work accomplished. Such requests for payment shall be verified and certified by the Procuring Entity’s Representative/Project Engineer. Except as otherwise stipulated in the **SCC**, materials and equipment delivered on the site but not completely put in place shall not be included for payment.

## **15. Operating and Maintenance Manuals**

15.1. If required, the Contractor will provide “as built” Drawings and/or operating and maintenance manuals as specified in the **SCC**.

- 15.2. If the Contractor does not provide the Drawings and/or manuals by the dates stated above, or they do not receive the Procuring Entity's Representative's approval, the Procuring Entity's Representative may withhold the amount stated in the **SCC** from payments due to the Contractor.

## ***Section V. Special Conditions of Contract***

### **Notes on the Special Conditions of Contract**

Similar to the BDS, the clauses in this Section are intended to assist the Procuring Entity in providing contract-specific information in relation to corresponding clauses in the GCC found in Section IV.

The Special Conditions of Contract (SCC) complement the GCC, specifying contractual requirements linked to the special circumstances of the Procuring Entity, the Procuring Entity's country, the sector, and the Works procured. In preparing this Section, the following aspects should be checked:

- a. Information that complements provisions of the GCC must be incorporated.
- b. Amendments and/or supplements to provisions of the GCC as necessitated by the circumstances of the specific purchase, must also be incorporated.

However, no special condition which defeats or negates the general intent and purpose of the provisions of the GCC should be incorporated herein.

# Special Conditions of Contract

GCC Clause	
2	Completion of work shall be within 90 calendar days.
4.1	The Procuring Entity shall give possession of all parts of the Site to the Contractor upon receipt of the Notice to Proceed.
6	The site investigation reports are: <i>[list here the required site investigation reports.]</i>
7.2	<p><i>[Select one, delete the other.]</i></p> <p><i>[In case of permanent structures, such as buildings of types 4 and 5 as classified under the National Building Code of the Philippines and other structures made of steel, iron, or concrete which comply with relevant structural codes (e.g., DPWH Standard Specifications), such as, but not limited to, steel/concrete bridges, flyovers, aircraft movement areas, ports, dams, tunnels, filtration and treatment plants, sewerage systems, power plants, transmission and communication towers, railway system, and other similar permanent structures:]</i> Fifteen (15) years.</p> <p><i>[In case of semi-permanent structures, such as buildings of types 1, 2, and 3 as classified under the National Building Code of the Philippines, concrete/asphalt roads, concrete river control, drainage, irrigation lined canals, river landing, deep wells, rock causeway, pedestrian overpass, and other similar semi-permanent structures:]</i> Five (5) years.</p> <p><i>[In case of other structures, such as bailey and wooden bridges, shallow wells, spring developments, and other similar structures:]</i> Two (2) years.</p>
10	Dayworks are applicable at the rate shown in the Contractor's original Bid.
13	The amount of the advance payment is no more that fifteen percent (15%) of the Contract Price subject to approval by the HOPE and compliance with the conditions under RA 9184 and its IRR.
14	No further instructions.
15.1	<p>The date by which operating and maintenance manuals are required is <i>thirty (30) days</i></p> <p>The date by which "as built" drawings are required as part of final payment</p>
15.2	The amount to be withheld for failing to produce "as built" drawings and/or operating and maintenance manuals by the date required is ten (10%) percent of the contract price.

## *Section VI. Specifications*

### **Notes on Specifications**

A set of precise and clear specifications is a prerequisite for Bidders to respond realistically and competitively to the requirements of the Procuring Entity without qualifying or conditioning their Bids. In the context of international competitive bidding, the specifications must be drafted to permit the widest possible competition and, at the same time, present a clear statement of the required standards of workmanship, materials, and performance of the goods and services to be procured. Only if this is done will the objectives of economy, efficiency, and fairness in procurement be realized, responsiveness of Bids be ensured, and the subsequent task of bid evaluation facilitated. The specifications should require that all goods and materials to be incorporated in the Works be new, unused, of the most recent or current models, and incorporate all recent improvements in design and materials unless provided otherwise in the Contract.

Samples of specifications from previous similar projects are useful in this respect. The use of metric units is mandatory. Most specifications are normally written specially by the Procuring Entity or its representative to suit the Works at hand. There is no standard set of Specifications for universal application in all sectors in all regions, but there are established principles and practices, which are reflected in these PBDs.

There are considerable advantages in standardizing General Specifications for repetitive Works in recognized public sectors, such as highways, ports, railways, urban housing, irrigation, and water supply, in the same country or region where similar conditions prevail. The General Specifications should cover all classes of workmanship, materials, and equipment commonly involved in construction, although not necessarily to be used in a particular Works Contract. Deletions or addenda should then adapt the General Specifications to the particular Works.

Care must be taken in drafting specifications to ensure that they are not restrictive. In the specification of standards for goods, materials, and workmanship, recognized international standards should be used as much as possible. Where other particular standards are used, whether national standards or other standards, the specifications should state that goods, materials, and workmanship that meet other authoritative standards, and which ensure substantially equal or higher quality than the standards mentioned, will also be acceptable. The following clause may be inserted in the SCC.

#### **Sample Clause: Equivalency of Standards and Codes**

Wherever reference is made in the Contract to specific standards and codes to be met by the goods and materials to be furnished, and work performed or tested, the provisions of the latest current edition or revision of the relevant standards and codes in effect shall apply, unless otherwise expressly stated in the Contract. Where such standards and codes are national, or relate to a particular country or region, other authoritative standards that ensure a substantially equal or higher quality than the standards and codes specified will be accepted

subject to the Procuring Entity's Representative's prior review and written consent. Differences between the standards specified and the proposed alternative standards shall be fully described in writing by the Contractor and submitted to the Procuring Entity's Representative at least twenty-eight (28) days prior to the date when the Contractor desires the Procuring Entity's Representative's consent. In the event the Procuring Entity's Representative determines that such proposed deviations do not ensure substantially equal or higher quality, the Contractor shall comply with the standards specified in the documents.

These notes are intended only as information for the Procuring Entity or the person drafting the Bidding Documents. They should not be included in the final Bidding Documents.





Republika ng Pilipinas  
Lungsod ng Quezon  
**CITY ENGINEERING DEPARTMENT**  
5th, 6th, 7th Floor, QC Civic Center Building "B"  
Telephone Nos. 8988-4242 Local 8538



**NAME OF PROJECT:** PROPOSED REHABILITATION OF ELECTRICAL SYSTEM AT  
DEMETRIO TUAZON ELEMENTARY SCHOOL

**LOCATION:** BARANGAY LOURDES, DISTRICT 1, QUEZON CITY

### TECHNICAL SPECIFICATIONS

#### **PART 1 – GENERAL**

##### **1.1 GENERAL REQUIREMENTS**

These supplemental items consist of temporary lighting & water facilities, billboard, construction safety net and health. Personnel Protective Equipment (PPE) should be used by the construction personnel or manpower at all times.

##### **1.2 SITE WORKS**

This item consists of disposal of material that has been and replaced.

##### **1.3 REFERENCE**

The publications listed below form a part of his specification to the extent referenced. the publications are referred to in the text by the basic designation only.

###### **1.3.1 American Society for Testing and Materials (ASTM)**

ASTM A123/A123M (2000) Zinc (Hot-dip Galvanized) Coatings On Iron and Steel Products

ASTM B1 (1995) Hard – Drawn Copper Wire

ASTM BB (1999) Concentric-Lay-Stranded Copper Conductor, Hard, Medium – Hard or Soft

###### **1.3.2 National Electrical Manufacturers Association (NEMA)**

NEMA C80.3 (1994) Electrical Metallic Tubing – zinc Coated (EMT)

NEMA c57.12.28 (1999) Pad mounted equipment-Enclosure Integrity

NEMA TC 2 (1998) Electrical Polyvinyl Chloride (PVC) Tubing (EPT) and Conduit (EPC- 40)

NEMA TC3 (1999) PVC Fittings for Use with Rigid PVC Conduit ant Tubing

NEMA WD 1 (1999) General requirements for Wiring Devices

**1.3.3 National Fire Protection Association (NFPA)**

NFPA 70                      (2002) National Electrical Code

**1.3.4 Underwriters Laboratories Inc. (UL)**

UL 1242                      (1996; Mar 1998) Intermediate Metal Conduit

UL 467                        (1993; Rev Apr 1999) Grounding & Bonding Equipment

UL 486A                      (1997; Rev Dec 1998) Wire Connection & Soldering Legs for Use  
with Copper Conductors

UL 486C                      (1997; Rev Aug 1998) Splicing Wire Connectors

UL 489                        (1996; Rev thru Dec 1998) Molded-Case Circuit Breakers

UL 50                         (1995; R 1999, Bul. 1999) Safety Enclosures for Electrical Equipment

UL510                        (1994; R Apr 1998) Poly Vinyl Chloride Polyethylene & Rubber  
Insulating Tape

UL 514A                      (1996; Rev Dec 1999) Metallic Outlet Boxes

UL 797                        (1993; R1997) Electrical Metallic Tubing

UL 83                         (1998; R 1999, Bul. 1999 & 2000) Thermoplastic-Insulated Wires &  
Cables

UL 869A                      (1998) Service Equipment

**1.3.5 Institute of Integrated Electrical Engineer (IIEE)**

PEC                          (2017) Philippine Electrical Code

**1.3.6 Philippine National Standard (PNS)**

BS                             (2002) Bureau of Standard

**1.4 SUBMITTALS**

Submit the following:

**1.4.1 Shop Drawings**

Panelboards

**1.4.2 Product Data**

Receptacles

Circuit breakers

Switches

Enclosed Circuit breakers

### 1.4.3 Test Reports

Insulation Resistance & Continuity test  
Grounding system test  
Functionality Test

## 1.5 MAINTENANCE

### 1.5.1 Electrical Systems

Submit operation and maintenance manuals for electrical systems that provide basic data relating to the design, operation, and maintenance of the electrical distribution system for the building.

This shall include:

- a. Single line diagram of the "as-built" building electrical system.
- b. Manufacturers' operating and maintenance manuals on active electrical equipment.

## PART 2 – PRODUCTS

### 2.1 MATERIALS AND EQUIPMENT

Materials, equipment, and devices shall, as a minimum, meet requirements of UL, where UL standards are established for those items, and requirements of NFPA 70 and PEC.

### 2.2 CONDUIT AND FITTINGS

Shall conform to the following:

#### 2.2.1 Rigid Nonmetallic Conduit

PVC Type EPC-40, in accordance with NEMA TC 2 and UL 651.

#### 2.2.2 Intermediate Metal Conduit (IMC)

UL 1242, zinc-coated steel only.

#### 2.2.3 Fittings for IMC threaded-type, Split couplings unacceptable.

#### 2.2.4 Fittings for Rigid Nonmetallic Conduit

NEMA TC 3.

### 2.3 WIRE AND CABLES

Wires and cables shall meet applicable requirements of NFPA 70, PEC and PNS and UL for type of Insulation, jacket, and conductor specified or indicated. Wires and cables manufactured more than 12 months prior to date of deliver to site shall not be used.

2.3.1 Conductors, shall be stranded unless specifically indicated otherwise. Conductor sizes and ampacities show are based on copper, unless indicated otherwise. All conductors shall be copper

#### 2.3.1.1 Equipment Manufacturer Requirements

When manufacturer's equipment requires copper conductors at the terminations or requires copper conductors to be provided between components, of equipment, provide copper conductors or splices, splice boxes, and other work required to satisfy manufacturer's requirements.

#### 2.3.2 Color Coding

Provide for service, feeder, branch, control, and signalling circuit conductors. Color shall be green for grounding conductors Color of ungrounded conductors in different voltage systems shall be as follows;

- a. 240 volt, single phase: black and red

#### 2.3.3 Insulation

Unless specified or indicated otherwise or required by NFPA 70, PEC and PNS, power and lighting wires shall be 600-volt. Type THW or THHN conforming to UL 83 except that grounding wire may be type TW conforming to UL 83, Where lighting fixtures require 90-degree Centigrade (C) conductors, provide only conductors with 90-degree C insulation or better.

#### 2.3.4 Bonding Conductors

ASTM B1, Solid bare copper wire for sizes 8mm<sup>2</sup> and smaller diameter, ASTM B8, Class B, stranded bare copper wire for sizes 14mm<sup>2</sup> and larger diameter.

### 2.4 SPLICES AND TERMINATION COMPONENTS

UL 486A for wire connectors and UL 510 for Insulating tapes, Connectors for 5.5 mm<sup>2</sup> and smaller diameter wires shall be insulated, pressure-type in accordance with UL 486A or UL 486C (twist-on splicing connector). Provide solderless terminal lugs on stranded conductors.

### 2.5 PANELBOARDS

UL 67 and UL 50 having a short-circuit current rating of 10,000 amperes symmetrical minimum, Panelboards for use as service disconnecting means shall additionally conform to UL 869A, Paneboards shall be circuit breaker-equipped. Design shall be such that individual breakers can be removed without disturbing adjacent units or without loosening or removing supplemental insulation supplied as means of obtaining clearances as required by UL "Specific breaker placement" is required in panelboards to match the breaker placement indicated in the panelboard schedule on the drawings, Use of \*Subfeed Breakers\* is not acceptable unless specifically indicated otherwise, Main breaker shall be \*Seperated\* mounted \*above\* branch breakers, Circuit breakers shall be bolt-on type, Where \*space only\* is indicated, make provisions for future installation of breakers. Panelboard locks shall be keyed same. Directories shall indicate load served by each circuit in panelboard, Directories shall also indicate source of service to panelboard (e.g. Panel PA served from Panel MDP), Type directories and mount in holder behind transparent protective covering. Panelboards shall be listed and labelled for their

intended use, Enclosure shall be galvanized steel gauge 14. Paint coating system shall comply with NEMA C57.12.28 for galvanized steel.

#### 2.5.1 Panelboard Buses

Support copper bus bars on bases independent of circuit breakers. Main buses and back pans shall be designed so that breakers may be changed without machining, drilling, or tapping. Provide separate ground bus identified as equipment grounding bus per UL 67 for connecting conducting bus per UL 67 form connecting grounding conductors, bond steel cabinet.

#### 2.5.2 Circuit Breakers

UL 489, thermal magnetic-type having a minimum short-circuit current rating equal to the short-circuit current rating of the panelboard in which the circuit breaker shall be mounted. Breaker terminals shall be UL listed as suitable for type of conductor provided. Series rated circuit breakers and plug-in circuit breakers without a self-contained bracket and not secured by a positive locking device requiring mechanical release for removal are unacceptable. Series rated circuit breakers and plug-in circuit breakers are unacceptable.

##### 2.5.2.1 Multipole Breakers

Provide common trip-type with single operating handle. Breaker design shall be such that overload in one pole automatically causes all poles to open. Maintain phase sequence throughout each panel so that three adjacent breaker poles are connected to Phases A,B, and C, respectively.

### 2.6 ENCLOSED CIRCUIT BREAKERS

UL 489, Individual molded case circuit breakers with voltage and continuous current ratings, number of poles, overload trip setting, and short circuit current interrupting rating as indicated. Enclosure type as indicated.

### 2.7 GROUNDING AND BONDING EQUIPMENT

UL 467, Ground rods shall be copper-clad steel, with minimum diameter of 20 mm and minimum length of 3050 mm.

## PART 3 – EXECUTION

### 3.1 INSTALLATION

Electrical installations shall conform to requirements of NFPA 70 and PEC and to requirements specified herein.

### 3.1.1 Wiring Methods

Provide insulated conductors installed in IMC, and rigid non-metallic conduit except where specifically indicated or specified otherwise or required by NFPA 70 and PEC to be installed otherwise, provide insulated green equipment grounding conductor for circuit(S) installed in conduit and raceways. Minimum conduit size shall be 15mm nominal inside diameter for low voltage lighting and power circuits.

#### 3.1.1.2 Nonmetallic Conduit

a. Restrictions applicable to PVC Schedule 40

(1) Do not use in areas where subject to severe physical damage

(2) Do not use above grade

#### 3.1.1.3 Service Entrance Conduit, Underground

PVC, type-EPC 40, underground portion shall be encased in minimum of 75 mm of concrete and shall be installed minimum 450 mm below slab or grade.

### 3.1.2 Conduit Installation

Unless indicated otherwise, conceal conduit under floor slabs and within finished walls ceilings, and floors, install conduit parallel with or at right angles to ceilings, walls, and structural members where located above accessible ceilings and where conduit will be visible after completion of project.

#### 3.1.2.1 Conduit through Floor Slabs

Where conduits rise through floor slabs. Curved portion of bends shall not be visible above finished slab.

#### 3.1.2.2 Conduit Support

Support conduit by pipe straps, wall brackets, hangers, or ceiling trapeze. Fasten by concrete inserts or expansion bolts on concrete and by machine screws, welded threaded studs, or spring-tension clamps on steel work. Threaded C-Clamps may be used on IMC conduit only. Do not weld conduits of pipe straps to steel structures, Load applied to fasteners shall not exceed one-fourth proof test load. Fasteners attached to concrete ceiling shall be vibration resistant and shock-resistant. Holes cut to depth of more than 40 mm in reinforced concrete beams or to depth of more than 20 mm in concrete joints shall not cut main reinforcing bars. Fill unused holes. In partitions of light steel construction, use sheet metal screws. In suspended-ceiling construction, run conduit above ceiling. Do not support conduit by ceiling support system. Conduit and box systems shall be supported independently of both (a) tie wires supporting ceiling grid system, and (b) ceiling grid system into which ceiling panels are placed. Supporting

means shall not be shared between electrical raceways and mechanical piping or ducts. Installation shall be coordinated with above-ceiling mechanical systems to assure

maximum accessibility to all systems. Spring-steel fasteners may be used for lighting branch circuit conduit supports in suspended ceilings in dry locations.

#### 3.1.2.3 Directional Changes in Conduit Runs

Make Changes in direction of runs with symmetrical bends or cast-metal fittings. Make field-made bends and offsets with hickey or conduit-bending machine. Do not install crushed or deformed conduits. Avoid trapped conduits. Prevent plaster, dirt, or trash from lodging in conduits, boxes, fittings, and equipment during construction. Free clogged conduits of obstructions.

#### 3.1.2.4 Pull Wire

Install pull wires in empty conduits, Pull wire shall be plastic having minimum 890-N tensile strength. Leave minimum 915 mm of slack at each end of pull wire.

#### 3.1.2.5 Conduit Installed in Concrete Floor Slabs

Locate so as not to adversely affect structural strength of slabs. Install conduit within middle one-third of concrete slab. Do not stack conduits. Space conduits horizontally not closer than three diameters, except at cabinet locations. Curved portions of bends shall not be visible above finish slab. Increase slab thickness as necessary to provide minimum 25 mm cover over conduit. Where embedded conduits cross building and/or expansion joints, provide suitable watertight expansion/deflection fittings and bonding jumpers. Expansion/deflection fittings shall allow horizontal and vertical movements of raceway. Conduit larger than 22 mm trade size shall be parallel with or at right angles to main reinforcement, when at right angles to reinforcement, conduit shall be close to one of supports of slab.

#### 3.1.2.6 Locknuts and Bushings

Fasten conduits to sheet metal boxes and cabinets with two locknuts where required by NFPA 70 and PEC where insulated bushings are used, and where bushings cannot be brought into firm contact with the box; otherwise, use at least minimum single locknut and bushing. Locknuts shall have sharp edges for digging into wall of metal enclosures. Install bushing on ends of conduits, and provide insulating type where required by NFPA 70 and PEC.

#### 3.1.3 Boxes, Outlets, and Supports

Provide boxes in wiring and raceway systems wherever required for pulling of wires, making connections, and mounting of devices or fixtures. Boxes for metallic raceways shall be cast-metal, except that nonmetallic boxes may be used with nonmetallic conduit system. Each box shall have volume required by NFPA 70 and PEC for number of conductors enclosed in box. Boxes for mounting lighting fixtures shall be minimum 100 mm square, or octagonal, except that smaller boxes may be installed as required by fixture configurations, as approved. Provide separate boxes for flush or recessed fixtures when required by fixture terminal operating temperature; fixtures shall be readily

removable for access to boxes unless ceiling access panels and provided, Support boxes and pendants for surface-mounted fixtures on suspended ceilings independently of ceiling supports, or make adequate provisions for distributing load over ceiling support members in an approved manner. Fasten boxes and supports with wood screws on wood. With bolts and expansion shields on concrete, with toggle bolts on hollow masonry units, and with machine screws or welded studs on steel.

#### 3.1.4 Conductor Identification

Provide conductor identification within each enclosure where tap, splice, or termination is made. For conductor's 14mm<sup>2</sup> and smaller diameter, color coding shall be by factory applied, color-impregnated insulation. For conductors 22mm<sup>2</sup> and larger diameter, color coding shall be by plastic-coated, self-sticking markers, colored nylon cable ties and plates; or heat shrink-type sleeves.

#### 3.1.5 Splices

Make splices in accessible locations, make splices in conductors 5.5mm<sup>2</sup> and smaller diameter with insulated, pressure-type connector, Make splices in conductors 22mm<sup>2</sup> and larger diameter with solderless connector, and cover with insulation material equivalent to conductor insulation.

Seal openings around electrical penetrations through fire resistance-rated walls, partitions, floor, or ceilings.

#### 3.1.6 Grounding and Bonding

In accordance with NFPA 70 and NEC. Ground exposed non-current-carrying metallic parts of electrical equipment, metallic raceway systems, grounding conductor in metallic and nonmetallic raceways, telephone system grounds. Make ground connection to driven ground rods on exterior of building. Interconnect all grounding media in or on the structure to provide a common ground potential.

##### 3.1.6.1 Resistance

Maximum resistance-to-ground of grounding system shall not exceed 5 ohms, contact Engineer for further instructions.

##### 3.1.6.2 Equipment Connections

Provide power wiring for the connection of motors and control equipment under this section of the specification. Except as otherwise specifically noted or specified, automatic control wiring, control devices, and protective devices within the control circuitry are not included in the section of the specifications but shall be provided under the section specifying the associated equipment.

### 3.2 FIELD QUALITY CONTROL

Furnish test equipment and personnel and submit written copies of test result. Give the engineer five (5) working days' notice prior to each test.



### 3.2.1 Insulation Resistance and Continuity Test

Upon completion of wiring installations, test wiring rated 600 volt and less to verify that no short circuits or accidental grounds exist. Perform insulation resistance test on wiring 14 mm<sup>2</sup> and larger diameter using insulation resistance test instrument which applies voltage of approximately 500 volts on provide direct reading of resistance, Minimum resistance shall be 250,000 ohms. This shall be well documented as test forms supervised by a licensed electrical practitioner with valid Professional Regulation Commission ID. Attached in this test form is a certificate of calibration.

### 3.2.2 Grounding Resistance Test

Upon completion of main service entrance, test grounding system to ensure continuity, and that resistance to ground is not excessive. Test each ground rod for resistance to ground before making connections to rod; tie grounding system together and test for resistance to ground. Make resistance measurements in dry weather, not earlier that 48 hours after rainfall. Submit written results of each test to Engineer, and indicate location of rods as well as resistance and soil conditions at time measurements were made. Minimum resistance shall be 5 ohms. This shall be well documented as test forms supervised by a licensed electrical practitioner with valid Professional Regulation Commission ID. Attached in this test form is a certificate of calibration.

### 3.2.3 Functionality Test

This shall be performed after completion of installation of wiring devices and lighting fixture/s. Wiring devices shall provide appropriate voltage for its respective equipment or appliance as detailed in the schedule of loads. All Lighting Fixtures shall provide appropriate color temperature and illumination as required. The switch/es nomenclature shall be able to control the fixture/s as referred by the 'as-built' plan. This shall be well documented as test forms supervised by a licensed electrical practitioner with valid Professional Regulation Commission ID. Attached in this test form is a certificate of calibration.

## PART 4 – CONCRETE WORKS

### 4.1 CONCRETE WORKS

Concrete works must be done using 2 bagger mixer with 3000psi or 4000psi with grade 40 or grade 60 reinforcing bars as specified in the plan and program of works.

PREPARED BY:



**KEVIN MICOLE R. DELFINO**

Planning and Programming Division

CHECKED BY:



**STEPHANIE D. OVIEDO**

Planning and Programming Division

## ***Section VII. Drawings***

*[Insert here a list of Drawings. The actual Drawings, including site plans, should be attached to this section, or annexed in a separate folder.]*

**THE SITE**



**1 VICINITY MAP**

NOT TO SCALE

**THE SITE**

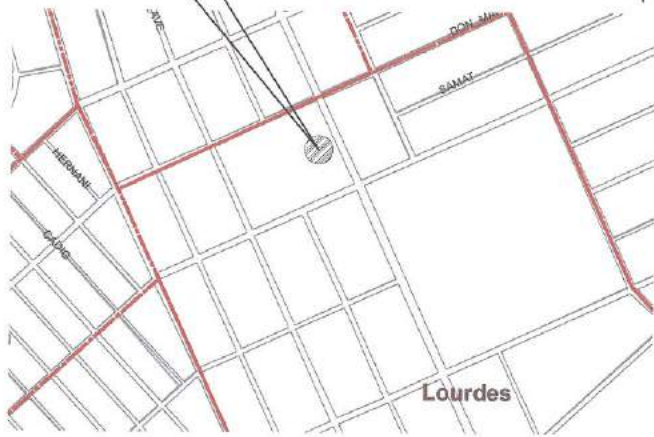

**2 LOCATION MAP**

NOT TO SCALE

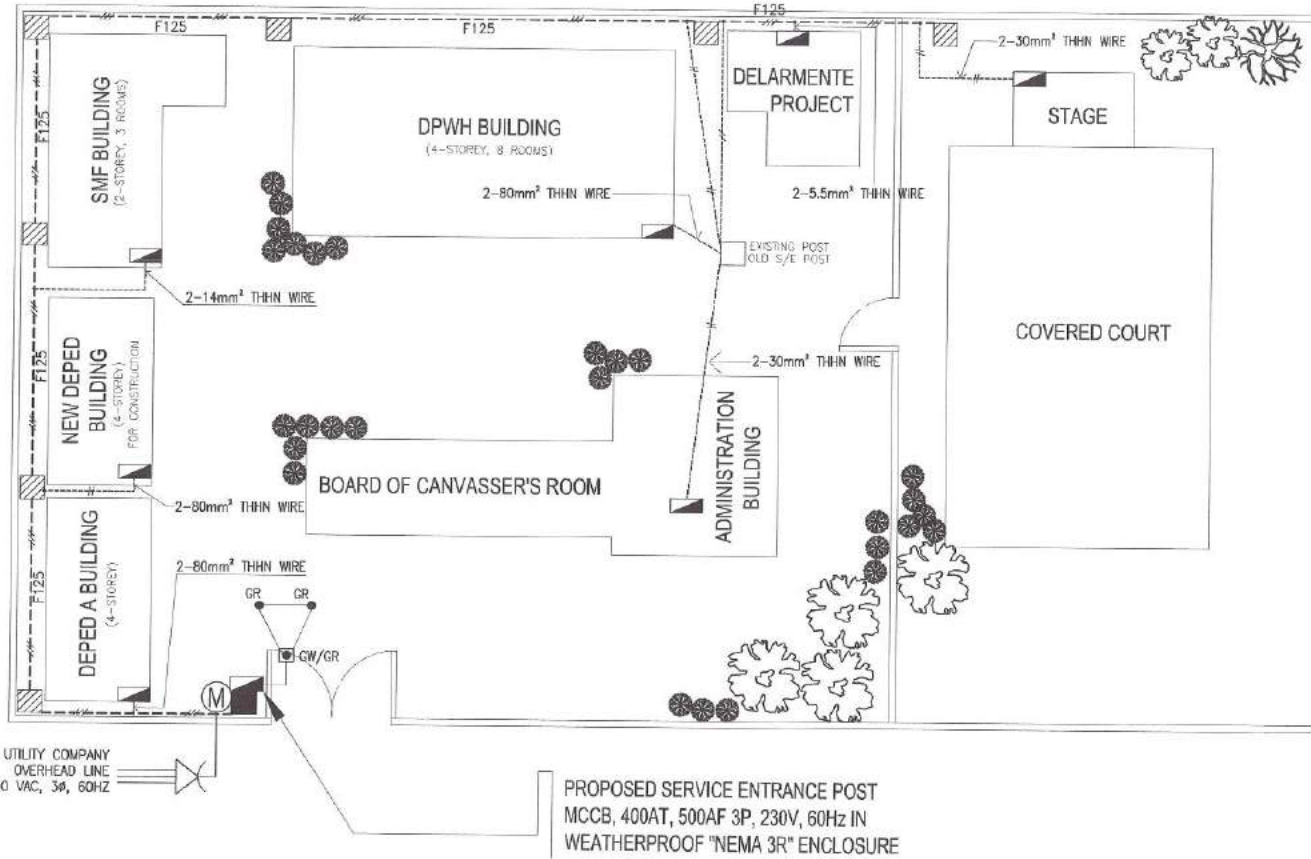

UTILITY COMPANY  
OVERHEAD LINE  
230 VAC, 3Ø, 60HZ

PROPOSED SERVICE ENTRANCE POST  
MCCB, 400AT, 500AF 3P, 230V, 60Hz IN  
WEATHERPROOF "NEMA 3R" ENCLOSURE

**3 SITE DEVELOPMENT PLAN / PROPOSED FEEDER LAYOUT**

NOT TO SCALE



Republika ng Pilipinas  
Lungsod ng Quezon  
**CITY ENGINEERING DEPARTMENT**

PROJECT TITLE:

**PROPOSED REHABILITATION OF  
ELECTRICAL SYSTEM AT DEMETRIO TUAZON  
ELEMENTARY SCHOOL**

LOCATION: BARANGAY LOURDES, DISTRICT 1, QUEZON CITY

DRAWN BY: *APM*

DATE: 11/19/2020

CHECKED BY: *ESB*

REVISION NO.:

SUBMITTED BY:

*[Signature]*

**ENGR. LEO S. DEL ROSARIO**  
HEAD, PLANNING & PROGRAMMING DIVISION

RECOMMENDING APPROVAL:

*[Signature]*

**ENGR. ISAGANI R. VERZOSA, JR.**  
C.E. CITY ENGINEERING DEPARTMENT

APPROVED BY:

*[Signature]*

**HON. MA. JOSEFINA G. BELMONTE**  
CITY MAYOR, QUEZON CITY

SHEET CONTENT

VICINITY MAP  
LOCATION MAP  
SITE DEVELOPMENT PLAN  
PROPOSED FEEDER  
LAYOUT

SHEET NO.

**EL  
01**

- ALL ELECTRICAL WORKS SHALL BE DONE IN ACCORDANCE WITH THE PROVISIONS OF THE LATEST EDITION OF THE PHILIPPINE ELECTRICAL CODE, THE LAWS AND ORDINANCES OF THE LOCAL CODE ENFORCING AUTHORITIES AND THE REQUIREMENTS OF THE LOCAL POWER AND TELEPHONE UTILITY COMPANY.
- THE CONTRACTOR SHALL SECURE ALL PERMITS AND PAY ALL FEES REQUIRED FOR THE WORK AND SHALL FURNISH THE OWNER THROUGH THE ENGINEERS, FINAL CERTIFICATES OF ELECTRICAL INSPECTION AND APPROVAL FROM PROPER GOVERNMENT AUTHORITIES FOR COMPLETION OF WORK.
- ALL EMBEDDED BRANCH CIRCUITS SHALL BE PVC CONDUITS AND FOR EXPOSED INSTALLATION SHALL BE IMC SUPPORTED BY CONDUIT CLAMPS EVERY 700 MILLIMETERS
- PULL BOXES SHALL BE PROVIDED BY THE CONTRACTOR WHENEVER NECESSARY TO FACILITATE WIRE PULLING EVEN IF THESE ARE NOT INDICATED ON THE PLANS. SIZING OF ALL PULLBOXES SHALL BE COMPUTED BASED ON THE CODE REQUIREMENTS. SUBMIT SHOP DRAWINGS TO THE ENGINEER FOR APPROVAL PRIOR TO FABRICATION. LOCATION OF PULLBOXES SHALL BE APPROVED BY THE ARCHITECT/ENGINEER AND MUST BE REFLECTED ON THE "AS-BUILT" PLAN.
- ALL POWER OUTLETS AND SWITCHES SHALL BE GROUNDING TYPE WITH PARALLEL SLOTS FOR 230 V.
- PROVIDE GROUND FAULT CURRENT INTERRUPTER CIRCUIT BREAKER FOR LOADS MARKED "GFCI" ON THE PLAN.
- ALL METALLIC CONDUITS, CABINETS AND EQUIPMENT SHALL BE PROPERLY GROUNDING AND BONDED.
- UNLESS OTHERWISE NOTED, MOUNTING HEIGHT FOR WALL MOUNTED DEVICES SHALL BE AS FOLLOWS:  
 RECEPTACLE OUTLET - 300 MM AFF, 150MM ABOVE WORKING COUNTER.  
 TELEPHONE OUTLET - 300 MM AFF  
 CATV OUTLET - 300 MM AFF  
 LIGHTING SWITCH - 1400 MM AFF  
 PANELBOARD - 1600 MM AFF

- ALL MATERIALS TO BE USED SHALL BE OF THE BEST QUALITY, BRAND NEW AS SPECIFIED.
- THE DRAWINGS AND SPECIFICATIONS ARE INTENDED TO PRESENT GENERAL LAYOUT AND BROAD OUTLINE/DESCRIPTION OF THE PROJECT BUT DO NOT NECESSARILY INDICATE/DESCRIBE ACTUAL LOCATIONS, LEVEL AND DISTANCES OF THE EQUIPMENT. THE CONTRACTOR IS HEREBY REQUIRED TO MAKE SUCH ADJUSTMENT AT THE JOBSITE AS LOCATION, DISTANCES AND LEVELS ARE GOVERNED BY ACTUAL FIELD CONDITIONS.
- ANY DISCREPANCY BETWEEN THE PLANS AND SPECIFICATIONS SHALL BE BROUGHT TO THE ATTENTION OF THE ENGINEER FOR CLARIFICATION DECISION.
- ALL LIGHTING AND CONVENIENCE OUTLET CIRCUITS SHALL BE 3.5 SQ. MM. THWN-2 COPPER WIRE UNLESS OTHERWISE NOTED. MINIMUM SIZE OF WIRE SHALL BE 3.5 SQ. MM. COPPER WIRE. ALL WIRES AND CABLES SHALL BE COLOR CODED AS FOLLOWS:  
 LINE 1 - RED  
 LINE 2 - YELLOW  
 NEUTRAL - WHITE  
 GROUND - GREEN

- BOXES, WIRE, GUTTERS, ENCLOSURE SHALL BE FABRICATED FROM STEEL WITH THICKNESS AS FOLLOWS:  
 MAXIMUM WIDTH OF THE WIDEST SURFACE STEEL  
 UP TO INCLUDING 152.40 MM GA  
 OVER 152.40 MM BUT NOT OVER 457.30 GA 15 PAINTED WITH METAL PRIMER EPOXY AND TOPCOAT  
 OVER 457.30 MM BUT NOT OVER 762 MM GA 14 PAINTED WITH METAL PRIMER EPOXY AND TOPCOAT  
 OVER 762 MM GA 12 PAINTED WITH METAL PRIMER EPOXY AND TOPCOAT  
 OVER 762 MM GA 10 PAINTED WITH METAL PRIMER EPOXY AND TOPCOAT
- ALL ELECTRICAL WORKS HEREIN SHALL BE EXECUTED BY EXPERIENCED MEN UNDER THE DIRECT SUPERVISION OF A FULL-TIME LICENSED ELECTRICAL ENGINEER AND A DULY ACCREDITED ELECTRICAL CONTRACTOR BY PCAB. WORKS SHALL BE NEATLY PLACED, SECURELY FASTENED AND PROPERLY FINISHED.
- TYPE OF SERVICE ENTRANCE SHALL BE SINGLE-PHASE, TWO-WIRE PLUS GROUND, 60 HERTZ, 230V AC NOMINAL.
- CONDUITS IN NO CASE SHALL THERE BE MORE THAN THE EQUIVALENT OF FOUR QUARTER BENDS IN ANY ONE RUN. ALL CONDUIT BENDS SHALL BE FIELD MADE BY USING HYDRAULIC BENDERS. MINIMUM BENDING RADIUS MUST BE IN ACCORDANCE TO THE CODE REQUIREMENTS.
- UPON COMPLETION OF ELECTRICAL CONSTRUCTION WORK, INSULATION RESISTANCE TEST AND FUNCTIONALITY TEST SHALL BE PERFORMED BY THE CONTRACTOR INCLUSIVE OF THE INSTALLATION TO BE REPORTED IN DETAILS ON FORMS APPROVED BY THE QUEZON CITY ENGINEERING DEPARTMENT REPRESENTATIVE. THE GROUND RESISTANCE FOR ELECTRICAL SYSTEMS SHALL NOT BE MORE THAN 5 OHMS. COMMUNICATION GROUNDING RESISTANCE SHALL NOT EXCEED 2 OHMS.

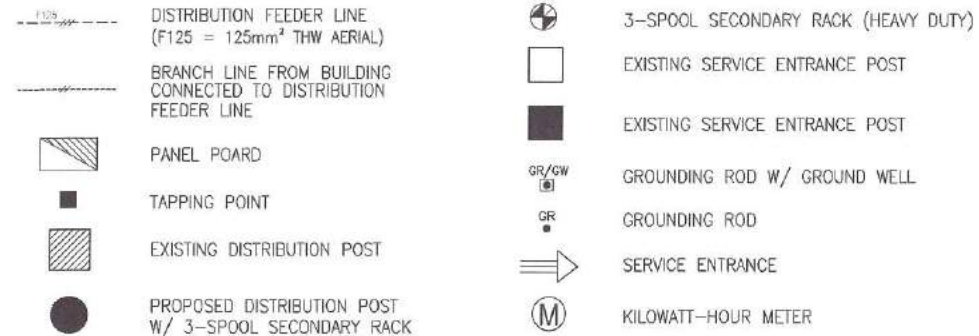

**2 LEGEND & SYMBOLS**

NOT TO SCALE

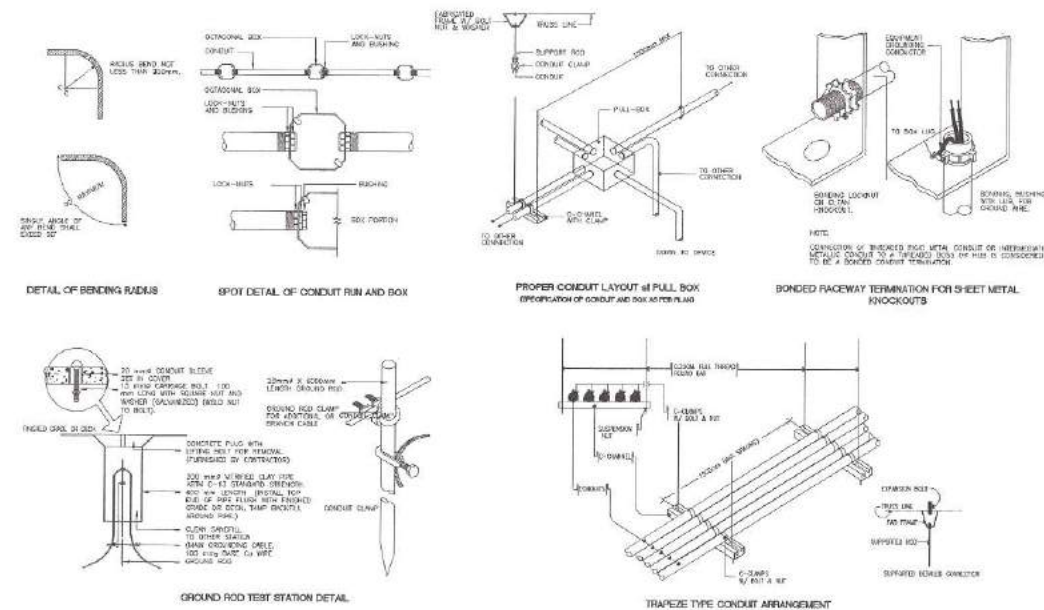

**1 GENERAL NOTES & SPECIFICATIONS**

NOT TO SCALE

**3 MISCELLANEOUS DETAILS**

NOT TO SCALE



Republika ng Pilipinas  
Lungsod ng Quezon  
**CITY ENGINEERING DEPARTMENT**

PROJECT TITLE:  
**PROPOSED REHABILITATION OF ELECTRICAL SYSTEM AT DEMETRIO TUAZON ELEMENTARY SCHOOL**

LOCATION: BARANGAY LOURDES, DISTRICT 1, QUEZON CITY

DRAWN BY: *KRS*  
DATE: 11/19/2020  
CHECKED BY: *[Signature]*  
REVISION NO.:

SUBMITTED BY:  
*[Signature]*  
**ENGR. LEO S. DEL ROSARIO**  
HEAD, PLANNING & PROGRAMMING DIVISION

RECOMMENDING APPROVAL:  
*[Signature]*  
**ENGR. ISAGANI R. VERZOSA, JR.**  
D.C. CITY ENGINEERING DEPARTMENT

APPROVED BY:  
*[Signature]*  
**HON. MA. JOSEFINA G. BELMONTE**  
CITY MAYOR, QUEZON CITY

SHEET CONTENT  
GENERAL NOTES & SPECIFICATIONS  
LEGEND & SYMBOLS  
MISCELLANEOUS DETAILS

SHEET NO.  
**EL 02**

**DEPED NEW BUILDING : LPP1**  
LOCATION: GROUND FLOOR & SECOND FLOOR

MOUNTING: NEMA1, SURFACE MOUNTED WITH GRAY POWDERED COATED FINISH WITH MULTI-TERMINAL BLOCK FOR SOLID GROUND BUS

CKT. NO.	LOAD DESCRIPTION	VOLTS	VA	AMP.	AT	SIZE OF	
						WIRES	CONDUITS
1	1-2HP WATER PUMP	230	2760	12.00	30	2-3.5mm <sup>2</sup> THHN COPPER WIRE 1-3.5mm <sup>2</sup> TW GROUND WIRE	IN 20mm <sup>Ø</sup> PVC PIPE
2	1-2HP WATER PUMP	230	2760	12.00	30	2-3.5mm <sup>2</sup> THHN COPPER WIRE 1-3.5mm <sup>2</sup> TW GROUND WIRE	IN 20mm <sup>Ø</sup> PVC PIPE
3	10-DUPLEX C.O.	230	1800	7.83	20	2-3.5mm <sup>2</sup> THHN COPPER WIRE 1-3.5mm <sup>2</sup> TW GROUND WIRE	IN 20mm <sup>Ø</sup> PVC PIPE
4	8-CEILING FAN	230	1200	5.21	20	2-3.5mm <sup>2</sup> THHN COPPER WIRE 1-3.5mm <sup>2</sup> TW GROUND WIRE	IN 20mm <sup>Ø</sup> PVC PIPE
5	8-CEILING FAN	230	1200	5.21	20	2-3.5mm <sup>2</sup> THHN COPPER WIRE 1-3.5mm <sup>2</sup> TW GROUND WIRE	IN 20mm <sup>Ø</sup> PVC PIPE
6	10-DUPLEX C.O.	230	1800	7.83	20	2-3.5mm <sup>2</sup> THHN COPPER WIRE 1-3.5mm <sup>2</sup> TW GROUND WIRE	IN 20mm <sup>Ø</sup> PVC PIPE
7	8-LIGHTING OUTLET	230	800	3.48	15	2-3.5mm <sup>2</sup> THHN COPPER WIRE 1-3.5mm <sup>2</sup> TW GROUND WIRE	IN 20mm <sup>Ø</sup> PVC PIPE
8	8-LIGHTING OUTLET	230	800	3.48	15	2-3.5mm <sup>2</sup> THHN COPPER WIRE 1-3.5mm <sup>2</sup> TW GROUND WIRE	IN 20mm <sup>Ø</sup> PVC PIPE
9	8-LIGHTING OUTLET	230	800	3.48	15	2-3.5mm <sup>2</sup> THHN COPPER WIRE 1-3.5mm <sup>2</sup> TW GROUND WIRE	IN 20mm <sup>Ø</sup> PVC PIPE
10	8-LIGHTING OUTLET	230	800	3.48	15	2-3.5mm <sup>2</sup> THHN COPPER WIRE 1-3.5mm <sup>2</sup> TW GROUND WIRE	IN 20mm <sup>Ø</sup> PVC PIPE
		14720	64.00				

**COMPUTATION :**  
 $IT = \frac{14720 VA + (25\% \times 2760 VA)}{230 V}$   
 IT = 67.00 AMP.

**OVER CURRENT PROTECTION:**  
 USE : 70AT, 2P, 230V MOULDED CASE CIRCUIT BREAKER IN NEMA 1

**MAIN FEEDER:**  
 USE : 2 - 14.0mm<sup>2</sup> THWN & 1-8.0mm<sup>2</sup> TW GROUND WIRE  
 IN 32mm<sup>Ø</sup> PVC PIPE / 25mm<sup>Ø</sup> IMC PIPE

**DEPED NEW BUILDING : LPP2 TYP. TO LPP3**  
LOCATION: THIRD FLOOR & FOURTH FLOOR

MOUNTING: NEMA1, SURFACE MOUNTED WITH GRAY POWDERED COATED FINISH WITH MULTI-TERMINAL BLOCK FOR SOLID GROUND BUS

CKT. NO.	LOAD DESCRIPTION	VOLTS	VA	AMP.	AT	SIZE OF	
						WIRES	CONDUITS
1	SPARE	230	-	-	30	2-3.5mm <sup>2</sup> THHN COPPER WIRE 1-3.5mm <sup>2</sup> TW GROUND WIRE	IN 20mm <sup>Ø</sup> PVC PIPE
2	SPARE	230	-	-	30	2-3.5mm <sup>2</sup> THHN COPPER WIRE 1-3.5mm <sup>2</sup> TW GROUND WIRE	IN 20mm <sup>Ø</sup> PVC PIPE
3	10-DUPLEX C.O.	230	1800	7.83	20	2-3.5mm <sup>2</sup> THHN COPPER WIRE 1-3.5mm <sup>2</sup> TW GROUND WIRE	IN 20mm <sup>Ø</sup> PVC PIPE
4	SPARE	230	-	-	20	2-3.5mm <sup>2</sup> THHN COPPER WIRE 1-3.5mm <sup>2</sup> TW GROUND WIRE	IN 20mm <sup>Ø</sup> PVC PIPE
5	8-CEILING FAN	230	1200	5.21	20	2-3.5mm <sup>2</sup> THHN COPPER WIRE 1-3.5mm <sup>2</sup> TW GROUND WIRE	IN 20mm <sup>Ø</sup> PVC PIPE
6	SPARE	230	-	-	20	2-3.5mm <sup>2</sup> THHN COPPER WIRE 1-3.5mm <sup>2</sup> TW GROUND WIRE	IN 20mm <sup>Ø</sup> PVC PIPE
7	8-LIGHTING OUTLET	230	800	3.48	15	2-3.5mm <sup>2</sup> THHN COPPER WIRE 1-3.5mm <sup>2</sup> TW GROUND WIRE	IN 20mm <sup>Ø</sup> PVC PIPE
8	SPARE	230	-	-	15	2-3.5mm <sup>2</sup> THHN COPPER WIRE 1-3.5mm <sup>2</sup> TW GROUND WIRE	IN 20mm <sup>Ø</sup> PVC PIPE
9	8-LIGHTING OUTLET	230	800	3.48	15	2-3.5mm <sup>2</sup> THHN COPPER WIRE 1-3.5mm <sup>2</sup> TW GROUND WIRE	IN 20mm <sup>Ø</sup> PVC PIPE
10	SPARE	230	-	-	15	2-3.5mm <sup>2</sup> THHN COPPER WIRE 1-3.5mm <sup>2</sup> TW GROUND WIRE	IN 20mm <sup>Ø</sup> PVC PIPE
		4600	20				

**COMPUTATION :**  
 $IT = \frac{4600 VA}{230 V}$   
 IT = 20.00 AMP.

**OVER CURRENT PROTECTION:**  
 USE : 70AT, 2P, 230V MOULDED CASE CIRCUIT BREAKER IN NEMA 1

**MAIN FEEDER:**  
 USE : 2 - 14.0mm<sup>2</sup> THWN & 1-8.0mm<sup>2</sup> TW GROUND WIRE  
 IN 32mm<sup>Ø</sup> PVC PIPE / 25mm<sup>Ø</sup> IMC PIPE

**DEPED NEW BUILDING : DP DEPED NEW**  
(FOR CONSTRUCTION-DESIGN PROVIDED BY DPWH)

MOUNTING: NEMA1, SURFACE MOUNTED WITH GRAY POWDERED COATED FINISH WITH MULTI-TERMINAL BLOCK FOR SOLID GROUND BUS

CKT. NO.	LOAD DESCRIPTION	VOLTS	VA	AMP.	AT	SIZE OF	
						WIRES	CONDUITS
1	LPP1	230	14720	64.00	70	2-14mm <sup>2</sup> THHN COPPER WIRE 1-8.0mm <sup>2</sup> TW GROUND WIRE	IN 32mm <sup>Ø</sup> PVC PIPE
2	LPP2	230	4600	20.00	70	2-14mm <sup>2</sup> THHN COPPER WIRE 1-8.0mm <sup>2</sup> TW GROUND WIRE	IN 32mm <sup>Ø</sup> PVC PIPE
3	LPP3	230	4600	20.00	70	2-14mm <sup>2</sup> THHN COPPER WIRE 1-8.0mm <sup>2</sup> TW GROUND WIRE	IN 32mm <sup>Ø</sup> PVC PIPE
		23920	104.00				

**COMPUTATION :**  
 $IT = \frac{23920 VA + (25\% \times 2760 VA)}{230 V}$   
 IT = 107.00 AMP.

**OVER CURRENT PROTECTION:**  
 USE : 200AT, 2P, 230V MOULDED CASE CIRCUIT BREAKER IN NEMA 1

**MAIN FEEDER:**  
 USE : 2 - 80mm<sup>2</sup> THWN & 1-22.0mm<sup>2</sup> TW GROUND WIRE  
 IN 63mm<sup>Ø</sup> PVC PIPE/50mm<sup>Ø</sup> IMC PIPE

**STAGE & COURT : DP-SC (PROPOSED)**  
LOCATION: STAGE

MOUNTING: NEMA1, SURFACE MOUNTED WITH GRAY POWDERED COATED FINISH WITH MULTI-TERMINAL BLOCK FOR SOLID GROUND BUS

CKT. NO.	LOAD DESCRIPTION	VOLTS	VA	AMP.	AT	SIZE OF	
						WIRES	CONDUITS
1	2-L.O. + 2-D.C.O.	230	460	2.00	20	2-3.5mm <sup>2</sup> THHN COPPER WIRE 1-3.5mm <sup>2</sup> TW GROUND WIRE	IN 20mm <sup>Ø</sup> PVC PIPE
2	6-(150W) HIGH BAY LIGHT	230	900	3.91	20	2-3.5mm <sup>2</sup> THHN COPPER WIRE 1-3.5mm <sup>2</sup> TW GROUND WIRE	IN 20mm <sup>Ø</sup> PVC PIPE
3	FOR FUNCTIONS	230	5620	24.34	40	2-8.0mm <sup>2</sup> THHN COPPER WIRE 1-3.5mm <sup>2</sup> TW GROUND WIRE	IN 32mm <sup>Ø</sup> PVC PIPE
4	FOR FUNCTIONS	230	5620	24.34	40	2-8.0mm <sup>2</sup> THHN COPPER WIRE 1-3.5mm <sup>2</sup> TW GROUND WIRE	IN 32mm <sup>Ø</sup> PVC PIPE
		12600	54.58				

**COMPUTATION :**  
 $IT = \frac{12600 VA}{230 V}$   
 IT = 54.58 AMP.

**OVER CURRENT PROTECTION:**  
 USE : 100AT, 2P, 230V MOULDED CASE CIRCUIT BREAKER IN NEMA 1

**MAIN FEEDER:**  
 USE : 2 - 30.0mm<sup>2</sup> THWN & 1-8.0mm<sup>2</sup> TW GROUND WIRE  
 IN 40mm<sup>Ø</sup> PVC PIPE / 32mm<sup>Ø</sup> IMC PIPE

**DELARMENTE BUILDING : DP-DELARMENTE**  
(EXISTING)

MOUNTING: NEMA1, SURFACE MOUNTED WITH GRAY POWDERED COATED FINISH WITH MULTI-TERMINAL BLOCK FOR SOLID GROUND BUS

CKT. NO.	LOAD DESCRIPTION	VOLTS	VA	AMP.	AT	SIZE OF	
						WIRES	CONDUITS
1	3-D.C.O. + 7-L.O.	230	1240	5.39	20	2-3.5mm <sup>2</sup> THHN COPPER WIRE 1-3.5mm <sup>2</sup> TW GROUND WIRE	IN 20mm <sup>Ø</sup> PVC PIPE
2	6-L.O. (C.R.)	230	600	2.61	20	2-3.5mm <sup>2</sup> THHN COPPER WIRE 1-3.5mm <sup>2</sup> TW GROUND WIRE	IN 20mm <sup>Ø</sup> PVC PIPE
		1840	8.00				



**COMPUTATION :**  
 $IT = \frac{1240 VA}{230 V}$   
 IT = 5.39 AMP.

**OVER CURRENT PROTECTION:**  
 USE : 30AT, 2P, 230V MOULDED CASE CIRCUIT BREAKER IN NEMA 1

**MAIN FEEDER:**  
 USE : 2 - 5.5mm<sup>2</sup> THWN & 1-3.5mm<sup>2</sup> TW GROUND WIRE  
 IN 25mm<sup>Ø</sup> PVC PIPE / 20mm<sup>Ø</sup> IMC PIPE

**1 SCHEDULE OF LOADS**

NOT TO SCALE

 <p>Republika ng Pilipinas Lungsod ng Quezon <b>CITY ENGINEERING DEPARTMENT</b></p>	PROJECT TITLE :	DRAWN BY: <i>[Signature]</i>	SUBMITTED BY:	RECOMMENDING APPROVAL:	APPROVED BY:	SHEET CONTENT	SHEET NO.	
	<p><b>PROPOSED REHABILITATION OF ELECTRICAL SYSTEM AT DEMETRIO TUAZON ELEMENTARY SCHOOL</b></p>	DATE: 11/19/2020	<i>[Signature]</i>	ENGR. LEO S. DEL ROSARIO HEAD, PLANNING & PROGRAMMING DIVISION	<i>[Signature]</i>	ENGR. ISAACANI R. VERZOSA, JR. C.E.C. CITY ENGINEERING DEPARTMENT	HON. MA. JOSEFINA G. BELMONTE CITY MAYOR, QUEZON CITY	SCHEDULE OF LOADS
	LOCATION: BARANGAY LOURDES, DISTRICT 1, QUEZON CITY	CHECKED BY: <i>[Signature]</i>	REVISION NO.:					

**DEPED A BUILDING : LPP1**  
LOCATION: GROUND FLOOR & SECOND FLOOR

MOUNTING: NEMA1, SURFACE MOUNTED WITH GRAY POWDERED COATED FINISH WITH MULTI-TERMINAL BLOCK FOR SOLID GROUND BUS

CKT. NO.	LOAD DESCRIPTION	VOLTS	VA	AMP.	AT	SIZE OF	
						WIRES	CONDUITS
1	1-2HP WATER PUMP	230	2760	12.00	30	2-3.5mm <sup>2</sup> THHN COPPER WIRE 1-3.5mm <sup>2</sup> TW GROUND WIRE	IN 20mm <sup>ø</sup> PVC PIPE
2	1-2HP WATER PUMP	230	2760	12.00	30	2-3.5mm <sup>2</sup> THHN COPPER WIRE 1-3.5mm <sup>2</sup> TW GROUND WIRE	IN 20mm <sup>ø</sup> PVC PIPE
3	10-DUPLEX C.O.	230	1800	7.83	20	2-3.5mm <sup>2</sup> THHN COPPER WIRE 1-3.5mm <sup>2</sup> TW GROUND WIRE	IN 20mm <sup>ø</sup> PVC PIPE
4	8-CEILING FAN	230	1200	5.21	20	2-3.5mm <sup>2</sup> THHN COPPER WIRE 1-3.5mm <sup>2</sup> TW GROUND WIRE	IN 20mm <sup>ø</sup> PVC PIPE
5	8-CEILING FAN	230	1200	5.21	20	2-3.5mm <sup>2</sup> THHN COPPER WIRE 1-3.5mm <sup>2</sup> TW GROUND WIRE	IN 20mm <sup>ø</sup> PVC PIPE
6	10-DUPLEX C.O.	230	1800	7.83	20	2-3.5mm <sup>2</sup> THHN COPPER WIRE 1-3.5mm <sup>2</sup> TW GROUND WIRE	IN 20mm <sup>ø</sup> PVC PIPE
7	8-LIGHTING OUTLET	230	800	3.48	15	2-3.5mm <sup>2</sup> THHN COPPER WIRE 1-3.5mm <sup>2</sup> TW GROUND WIRE	IN 20mm <sup>ø</sup> PVC PIPE
8	8-LIGHTING OUTLET	230	800	3.48	15	2-3.5mm <sup>2</sup> THHN COPPER WIRE 1-3.5mm <sup>2</sup> TW GROUND WIRE	IN 20mm <sup>ø</sup> PVC PIPE
9	8-LIGHTING OUTLET	230	800	3.48	15	2-3.5mm <sup>2</sup> THHN COPPER WIRE 1-3.5mm <sup>2</sup> TW GROUND WIRE	IN 20mm <sup>ø</sup> PVC PIPE
10	8-LIGHTING OUTLET	230	800	3.48	15	2-3.5mm <sup>2</sup> THHN COPPER WIRE 1-3.5mm <sup>2</sup> TW GROUND WIRE	IN 20mm <sup>ø</sup> PVC PIPE
			14720	64.00			

**COMPUTATION :**  
 $IT = \frac{14720 VA + (25\% \times 2760 VA)}{230 V}$   
 $IT = 67.99 AMP.$

**OVER CURRENT PROTECTION:**  
 USE : 70AT, 2P, 230V MOULDED CASE CIRCUIT BREAKER IN NEMA 1

**MAIN FEEDER:**  
 USE : 2 - 14.0mm<sup>2</sup> THWN & 1-8.0mm<sup>2</sup> TW GROUND WIRE  
 IN 32mm<sup>ø</sup> PVC PIPE / 25mm<sup>ø</sup> IMC PIPE

**DEPED A BUILDING : LPP2 TYP. TO LPP3**  
LOCATION: THIRD FLOOR & FOURTH FLOOR

MOUNTING: NEMA1, SURFACE MOUNTED WITH GRAY POWDERED COATED FINISH WITH MULTI-TERMINAL BLOCK FOR SOLID GROUND BUS

CKT. NO.	LOAD DESCRIPTION	VOLTS	VA	AMP.	AT	SIZE OF	
						WIRES	CONDUITS
1	SPARE	230	-	-	30	2-3.5mm <sup>2</sup> THHN COPPER WIRE 1-3.5mm <sup>2</sup> TW GROUND WIRE	IN 20mm <sup>ø</sup> PVC PIPE
2	SPARE	230	-	-	30	2-3.5mm <sup>2</sup> THHN COPPER WIRE 1-3.5mm <sup>2</sup> TW GROUND WIRE	IN 20mm <sup>ø</sup> PVC PIPE
3	10-DUPLEX C.O.	230	1800	7.83	20	2-3.5mm <sup>2</sup> THHN COPPER WIRE 1-3.5mm <sup>2</sup> TW GROUND WIRE	IN 20mm <sup>ø</sup> PVC PIPE
4	SPARE	230	-	-	20	2-3.5mm <sup>2</sup> THHN COPPER WIRE 1-3.5mm <sup>2</sup> TW GROUND WIRE	IN 20mm <sup>ø</sup> PVC PIPE
5	8-CEILING FAN	230	1200	5.21	20	2-3.5mm <sup>2</sup> THHN COPPER WIRE 1-3.5mm <sup>2</sup> TW GROUND WIRE	IN 20mm <sup>ø</sup> PVC PIPE
6	SPARE	230	-	-	20	2-3.5mm <sup>2</sup> THHN COPPER WIRE 1-3.5mm <sup>2</sup> TW GROUND WIRE	IN 20mm <sup>ø</sup> PVC PIPE
7	8-LIGHTING OUTLET	230	800	3.48	15	2-3.5mm <sup>2</sup> THHN COPPER WIRE 1-3.5mm <sup>2</sup> TW GROUND WIRE	IN 20mm <sup>ø</sup> PVC PIPE
8	SPARE	230	-	-	15	2-3.5mm <sup>2</sup> THHN COPPER WIRE 1-3.5mm <sup>2</sup> TW GROUND WIRE	IN 20mm <sup>ø</sup> PVC PIPE
9	8-LIGHTING OUTLET	230	800	3.48	15	2-3.5mm <sup>2</sup> THHN COPPER WIRE 1-3.5mm <sup>2</sup> TW GROUND WIRE	IN 20mm <sup>ø</sup> PVC PIPE
10	SPARE	230	-	-	15	2-3.5mm <sup>2</sup> THHN COPPER WIRE 1-3.5mm <sup>2</sup> TW GROUND WIRE	IN 20mm <sup>ø</sup> PVC PIPE
			4600	20			

**COMPUTATION :**  
 $IT = \frac{4600 VA}{230 V}$   
 $IT = 20.00 AMP.$

**OVER CURRENT PROTECTION:**  
 USE : 70AT, 2P, 230V MOULDED CASE CIRCUIT BREAKER IN NEMA 1

**MAIN FEEDER:**  
 USE : 2 - 14.0mm<sup>2</sup> THWN & 1-8.0mm<sup>2</sup> TW GROUND WIRE  
 IN 32mm<sup>ø</sup> PVC PIPE / 25mm<sup>ø</sup> IMC PIPE

**DEPED A BUILDING : DP DEPED NEW**  
(EXISTING-DESIGN PROVIDED BY DPWH)

MOUNTING: NEMA1, SURFACE MOUNTED WITH GRAY POWDERED COATED FINISH WITH MULTI-TERMINAL BLOCK FOR SOLID GROUND BUS

CKT. NO.	LOAD DESCRIPTION	VOLTS	VA	AMP.	AT	SIZE OF	
						WIRES	CONDUITS
1	LPP1	230	14720	64.00	70	2-14mm <sup>2</sup> THHN COPPER WIRE 1-8.0mm <sup>2</sup> TW GROUND WIRE	IN 32mm <sup>ø</sup> PVC PIPE
2	LPP2	230	4600	20.00	70	2-14mm <sup>2</sup> THHN COPPER WIRE 1-8.0mm <sup>2</sup> TW GROUND WIRE	IN 32mm <sup>ø</sup> PVC PIPE
3	LPP3	230	4600	20.00	70	2-14mm <sup>2</sup> THHN COPPER WIRE 1-8.0mm <sup>2</sup> TW GROUND WIRE	IN 32mm <sup>ø</sup> PVC PIPE
			23920	104.00			

**COMPUTATION :**  
 $IT = \frac{23920 VA + (25\% \times 2760 VA)}{230 V}$   
 $IT = 107.00 AMP.$

**OVER CURRENT PROTECTION:**  
 USE : 200AT, 2P, 230V MOULDED CASE CIRCUIT BREAKER IN NEMA 1

**MAIN FEEDER:**  
 USE : 2 - 80.0mm<sup>2</sup> THWN & 1-22.0mm<sup>2</sup> TW GROUND WIRE  
 IN 63mm<sup>ø</sup> PVC PIPE/50mm<sup>ø</sup> IMC PIPE

**ADMINISTRATION BUILDING : DP-ADMIN**  
(PROPOSED)

MOUNTING: NEMA1, SURFACE MOUNTED WITH GRAY POWDERED COATED FINISH WITH MULTI-TERMINAL BLOCK FOR SOLID GROUND BUS

CKT. NO.	LOAD DESCRIPTION	VOLTS	VA	AMP.	AT	SIZE OF	
						WIRES	CONDUITS
1	13-L.O. + 4-CEILING FAN(150W)	230	1900	8.26	20	2-3.5mm <sup>2</sup> THHN COPPER WIRE 1-3.5mm <sup>2</sup> TW GROUND WIRE	IN 20mm <sup>ø</sup> PVC PIPE
2	4-D.C.O.	230	720	3.13	20	2-3.5mm <sup>2</sup> THHN COPPER WIRE 1-3.5mm <sup>2</sup> TW GROUND WIRE	IN 20mm <sup>ø</sup> PVC PIPE
3	13-L.O. + 4-CEILING FAN(150W)	230	1900	8.26	20	2-3.5mm <sup>2</sup> THHN COPPER WIRE 1-3.5mm <sup>2</sup> TW GROUND WIRE	IN 20mm <sup>ø</sup> PVC PIPE
4	4-D.C.O.	230	720	3.13	20	2-3.5mm <sup>2</sup> THHN COPPER WIRE 1-3.5mm <sup>2</sup> TW GROUND WIRE	IN 20mm <sup>ø</sup> PVC PIPE
5	13-L.O. + 4-CEILING FAN(150W)	230	1900	8.26	20	2-3.5mm <sup>2</sup> THHN COPPER WIRE 1-3.5mm <sup>2</sup> TW GROUND WIRE	IN 20mm <sup>ø</sup> PVC PIPE
6	4-D.C.O.	230	720	3.13	20	2-3.5mm <sup>2</sup> THHN COPPER WIRE 1-3.5mm <sup>2</sup> TW GROUND WIRE	IN 20mm <sup>ø</sup> PVC PIPE
7	13-L.O. + 4-CEILING FAN(150W)	230	1900	8.26	20	2-3.5mm <sup>2</sup> THHN COPPER WIRE 1-3.5mm <sup>2</sup> TW GROUND WIRE	IN 20mm <sup>ø</sup> PVC PIPE
8	4-D.C.O.	230	720	3.13	20	2-3.5mm <sup>2</sup> THHN COPPER WIRE 1-3.5mm <sup>2</sup> TW GROUND WIRE	IN 20mm <sup>ø</sup> PVC PIPE
9	13-L.O. + 4-CEILING FAN(150W)	230	1900	8.26	20	2-3.5mm <sup>2</sup> THHN COPPER WIRE 1-3.5mm <sup>2</sup> TW GROUND WIRE	IN 20mm <sup>ø</sup> PVC PIPE
10	4-D.C.O.	230	720	3.13	20	2-3.5mm <sup>2</sup> THHN COPPER WIRE 1-3.5mm <sup>2</sup> TW GROUND WIRE	IN 20mm <sup>ø</sup> PVC PIPE
11	13-L.O. + 4-CEILING FAN(150W)	230	1900	8.26	20	2-3.5mm <sup>2</sup> THHN COPPER WIRE 1-3.5mm <sup>2</sup> TW GROUND WIRE	IN 20mm <sup>ø</sup> PVC PIPE
12	4-D.C.O.	230	720	3.13	20	2-3.5mm <sup>2</sup> THHN COPPER WIRE 1-3.5mm <sup>2</sup> TW GROUND WIRE	IN 20mm <sup>ø</sup> PVC PIPE
13	1-3HP SPLIT TYPE ACU	230	3910	17	30	2-3.5mm <sup>2</sup> THHN COPPER WIRE 1-3.5mm <sup>2</sup> TW GROUND WIRE	IN 20mm <sup>ø</sup> PVC PIPE
14	5-D.C.O.	230	900	3.91	20	2-3.5mm <sup>2</sup> THHN COPPER WIRE 1-3.5mm <sup>2</sup> TW GROUND WIRE	IN 20mm <sup>ø</sup> PVC PIPE
			20530	89.26			

**COMPUTATION :**  
 $IT = \frac{20530 VA + (25\% \times 3910 VA)}{230 V}$   
 $IT = 93.51 AMP.$

**OVER CURRENT PROTECTION:**  
 USE : 100AT, 2P, 230V MOULDED CASE CIRCUIT BREAKER IN NEMA 1

**MAIN FEEDER:**  
 USE : 2 - 30mm<sup>2</sup> THWN & 1-8.0mm<sup>2</sup> TW GROUND WIRE  
 IN 40mm<sup>ø</sup> PVC PIPE / 32mm<sup>ø</sup> IMC PIPE

**1 SCHEDULE OF LOADS**

NOT TO SCALE



Republika ng Pilipinas  
Lungsod ng Quezon  
**CITY ENGINEERING DEPARTMENT**

PROJECT TITLE :  
**PROPOSED REHABILITATION OF ELECTRICAL SYSTEM AT DEMETRIO TUAZON ELEMENTARY SCHOOL**

LOCATION: BARANGAY LOURDES, DISTRICT 1, QUEZON CITY

DRAWN BY: *[Signature]*  
DATE: 11/02/20  
CHECKED BY: *[Signature]*  
REVISION NO.:

SUBMITTED BY:  
*[Signature]*  
**ENGR. LEO S. DEL ROSARIO**  
HEAD, PLANNING & PROGRAMMING DIVISION

RECOMMENDING APPROVAL:  
*[Signature]*  
**ENGR. ISABELA R. VERZOSA, JR.**  
CITY ENGINEERING DEPARTMENT

APPROVED BY:  
*[Signature]*  
**HON. MA. JOSEFINA G. BELMONTE**  
CITY MAYOR, QUEZON CITY

SHEET CONTENT  
SCHEDULE OF LOADS

SHEET NO.

**EL 04**

**SMF BUILDING : LPPA-SMF TYP. TO LPPB-SMF**  
 LOCATION: GROUND FLOOR (EXISTING)

MOUNTING: NEMA1, SURFACE MOUNTED WITH GRAY POWDERED COATED FINISH WITH MULTI-TERMINAL BLOCK FOR SOLID GROUND BUS

CKT. NO.	LOAD DESCRIPTION	VOLTS	VA	AMP.	AT	SIZE OF	
						WIRES	CONDUITS
1	3-LIGHTING OUTLETS	230	300	1.30	15	2-3.5mm <sup>2</sup> THHN COPPER WIRE 1-3.5mm <sup>2</sup> TW GROUND WIRE	IN 20mm <sup>ø</sup> PVC PIPE
2	4-LIGHTING OUTLETS	230	400	1.74	15	2-3.5mm <sup>2</sup> THHN COPPER WIRE 1-3.5mm <sup>2</sup> TW GROUND WIRE	IN 20mm <sup>ø</sup> PVC PIPE
3	3-LIGHTING OUTLETS	230	300	1.30	15	2-3.5mm <sup>2</sup> THHN COPPER WIRE 1-3.5mm <sup>2</sup> TW GROUND WIRE	IN 20mm <sup>ø</sup> PVC PIPE
4	4-LIGHTING OUTLETS	230	400	1.74	15	2-3.5mm <sup>2</sup> THHN COPPER WIRE 1-3.5mm <sup>2</sup> TW GROUND WIRE	IN 20mm <sup>ø</sup> PVC PIPE
5	3-DUPLEX CONVENIENCE OUTLETS	230	540	2.35	20	2-3.5mm <sup>2</sup> THHN COPPER WIRE 1-3.5mm <sup>2</sup> TW GROUND WIRE	IN 20mm <sup>ø</sup> PVC PIPE
6	4-DUPLEX CONVENIENCE OUTLETS	230	720	3.13	20	2-3.5mm <sup>2</sup> THHN COPPER WIRE 1-3.5mm <sup>2</sup> TW GROUND WIRE	IN 20mm <sup>ø</sup> PVC PIPE
7	4-DUPLEX CONVENIENCE OUTLETS	230	720	3.13	20	2-3.5mm <sup>2</sup> THHN COPPER WIRE 1-3.5mm <sup>2</sup> TW GROUND WIRE	IN 20mm <sup>ø</sup> PVC PIPE
8	SPARE	230	-	-	-	EMPTY	EMPTY
		3380	14.69				

**COMPUTATION :**  
 $IT = \frac{3380 VA}{230 V}$   
 $IT = 14.69 AMP.$

OVER CURRENT PROTECTION  
 USE : 40AT, 2P, 230V MOULDED CASE CIRCUIT BREAKER IN NEMA 1

MAIN FEEDER:  
 USE : 2 - 8.0mm<sup>2</sup> THWN & 1-5.5mm<sup>2</sup> TW GROUND WIRE  
 IN 32mm<sup>ø</sup> PVC PIPE / 25mm<sup>ø</sup> IMC PIPE

**SMF BUILDING : DP-SMF**  
 LOCATION: GROUND FLOOR (PROPOSED)

MOUNTING: NEMA1, SURFACE MOUNTED WITH GRAY POWDERED COATED FINISH WITH MULTI-TERMINAL BLOCK FOR SOLID GROUND BUS

CKT. NO.	LOAD DESCRIPTION	VOLTS	VA	AMP.	AT	SIZE OF	
						WIRES	CONDUITS
1	LPPA-SM BLDG.	230	3380	14.69	40	2-8.0mm <sup>2</sup> THHN COPPER WIRE 1-5.5mm <sup>2</sup> TW GROUND WIRE	IN 32mm <sup>ø</sup> PVC PIPE
2	LPPB-SM BLDG.	230	3380	14.69	40	2-8.0mm <sup>2</sup> THHN COPPER WIRE 1-5.5mm <sup>2</sup> TW GROUND WIRE	IN 32mm <sup>ø</sup> PVC PIPE
		6760	29.38				

**COMPUTATION :**  
 $IT = \frac{6760 VA}{230 V}$   
 $IT = 29.38 AMP.$

OVER CURRENT PROTECTION  
 USE : 50AT, 2P, 230V MOULDED CASE CIRCUIT BREAKER IN NEMA 3R

MAIN FEEDER:  
 USE : 2 - 14.0mm<sup>2</sup> THWN & 1-5.5mm<sup>2</sup> TW GROUND WIRE  
 IN 32mm<sup>ø</sup> PVC PIPE / 25mm<sup>ø</sup> IMC PIPE

**DPWH BUILDING : LPPA**  
 LOCATION: GROUND FLOOR (EXISTING)

MOUNTING: NEMA1, SURFACE MOUNTED WITH GRAY POWDERED COATED FINISH WITH MULTI-TERMINAL BLOCK FOR SOLID GROUND BUS

CKT. NO.	LOAD DESCRIPTION	VOLTS	VA	AMP.	AT	SIZE OF	
						WIRES	CONDUITS
1	8-L.O. + 8-CEILING FAN	230	2000	8.70	15	2-3.5mm <sup>2</sup> THHN COPPER WIRE 1-3.5mm <sup>2</sup> TW GROUND WIRE	IN 20mm <sup>ø</sup> PVC PIPE
2	8-L.O. + 8-CEILING FAN	230	2000	8.70	15	2-3.5mm <sup>2</sup> THHN COPPER WIRE 1-3.5mm <sup>2</sup> TW GROUND WIRE	IN 20mm <sup>ø</sup> PVC PIPE
3	10-DUPLEX C.O.	230	1800	7.83	20	2-3.5mm <sup>2</sup> THHN COPPER WIRE 1-3.5mm <sup>2</sup> TW GROUND WIRE	IN 20mm <sup>ø</sup> PVC PIPE
4	10-DUPLEX C.O.	230	1800	7.83	20	2-3.5mm <sup>2</sup> THHN COPPER WIRE 1-3.5mm <sup>2</sup> TW GROUND WIRE	IN 20mm <sup>ø</sup> PVC PIPE
5	FACP	230	5000	21.71	30	2-5.5mm <sup>2</sup> THHN COPPER WIRE 1-3.5mm <sup>2</sup> TW GROUND WIRE	IN 25mm <sup>ø</sup> PVC PIPE
6	SPARE	230	-	-	20	2-3.5mm <sup>2</sup> THHN COPPER WIRE 1-3.5mm <sup>2</sup> TW GROUND WIRE	IN 20mm <sup>ø</sup> PVC PIPE
		12600	54.78				

**COMPUTATION :**  
 $IT = \frac{12600 VA}{230 V}$   
 $IT = 54.78 AMP.$

OVER CURRENT PROTECTION  
 USE : 60AT, 2P, 230V MOULDED CASE CIRCUIT BREAKER IN NEMA 1

MAIN FEEDER:  
 USE : 2 - 14.0mm<sup>2</sup> THWN & 1-5.5mm<sup>2</sup> TW GROUND WIRE  
 IN 32mm<sup>ø</sup> PVC PIPE / 25mm<sup>ø</sup> IMC PIPE

**DPWH BUILDING : LPPB/LPPC/LPPD**  
 LOCATION: SECOND FLOOR, THIRD FLOOR & FOURTH FLOOR (EXISTING)

MOUNTING: NEMA1, SURFACE MOUNTED WITH GRAY POWDERED COATED FINISH WITH MULTI-TERMINAL BLOCK FOR SOLID GROUND BUS

CKT. NO.	LOAD DESCRIPTION	VOLTS	VA	AMP.	AT	SIZE OF	
						WIRES	CONDUITS
1	8-L.O. + 8-CEILING FAN	230	2000	8.70	15	2-3.5mm <sup>2</sup> THHN COPPER WIRE 1-3.5mm <sup>2</sup> TW GROUND WIRE	IN 20mm <sup>ø</sup> PVC PIPE
2	8-L.O. + 8-CEILING FAN	230	2000	8.70	15	2-3.5mm <sup>2</sup> THHN COPPER WIRE 1-3.5mm <sup>2</sup> TW GROUND WIRE	IN 20mm <sup>ø</sup> PVC PIPE
3	10-DUPLEX C.O.	230	1800	7.83	20	2-3.5mm <sup>2</sup> THHN COPPER WIRE 1-3.5mm <sup>2</sup> TW GROUND WIRE	IN 20mm <sup>ø</sup> PVC PIPE
4	10-DUPLEX C.O.	230	1800	7.83	20	2-3.5mm <sup>2</sup> THHN COPPER WIRE 1-3.5mm <sup>2</sup> TW GROUND WIRE	IN 20mm <sup>ø</sup> PVC PIPE
5	SPARE	230	-	-	30	2-3.5mm <sup>2</sup> THHN COPPER WIRE 1-3.5mm <sup>2</sup> TW GROUND WIRE	IN 20mm <sup>ø</sup> PVC PIPE
6	SPARE	230	-	-	20	2-3.5mm <sup>2</sup> THHN COPPER WIRE 1-3.5mm <sup>2</sup> TW GROUND WIRE	IN 20mm <sup>ø</sup> PVC PIPE
		7600	33.04				

**COMPUTATION :**  
 $IT = \frac{7600 VA}{230 V}$   
 $IT = 33.04 AMP.$

OVER CURRENT PROTECTION  
 USE : 60AT, 2P, 230V MOULDED CASE CIRCUIT BREAKER IN NEMA 1

MAIN FEEDER:  
 USE : 2 - 14.0mm<sup>2</sup> THWN & 1-5.5mm<sup>2</sup> THWN GROUND WIRE  
 IN 32mm<sup>ø</sup> PVC PIPE / 25mm<sup>ø</sup> IMC PIPE

1 SCHEDULE OF LOADS

NOT TO SCALE

 <p>Republika ng Pilipinas                  Lungsod ng Quezon  <b>CITY ENGINEERING DEPARTMENT</b></p>	PROJECT TITLE :	DRAWN BY: <i>WMD</i>	SUBMITTED BY:	RECOMMENDING APPROVAL:	APPROVED BY:	SHEET CONTENT	SHEET NO.	
	PROPOSED REHABILITATION OF ELECTRICAL SYSTEM AT DEMETRIO TUAZON ELEMENTARY SCHOOL	DATE: 11/19/2020	<i>[Signature]</i>	<i>[Signature]</i>	<i>[Signature]</i>	HON. MA. JOSEFINA G. BELMONTE CITY MAYOR, QUEZON CITY	PANEL BOARD DETAILS	<b>EL 05</b>
	LOCATION: BARANGAY LOURDES, DISTRICT 1, QUEZON CITY	REVISION NO.:	ENGR. LEO S. DEL ROSARIO HEAD, PLANNING & PROGRAMMING DIVISION	ENGR. ISABANI R. VERZOSA, JR. C.E. CITY ENGINEERING DEPARTMENT				

**DPWH BUILDING : DP-DPWH**

LOCATION: GROUND FLOOR (EXISTING)

MOUNTING: NEMA1, SURFACE MOUNTED WITH GRAY POWDERED COATED FINISH WITH MULTI-TERMINAL BLOCK FOR SOLID GROUND BUS

CKT. NO.	LOAD DESCRIPTION	VOLTS	VA	AMP.	AT	SIZE OF	
						WIRES	CONDUITS
1	LPPA-DEPED(DPWH)	230	12600	54.76	60	2-14.0mm <sup>2</sup> THWN COPPER WIRE 1-5.5mm <sup>2</sup> THWN GROUND WIRE	IN 32mm <sup>9</sup> PVC PIPE
2	LPPB-DEPED DPWH	230	7600	33.04	60	2-14.0mm <sup>2</sup> THWN COPPER WIRE 1-5.5mm <sup>2</sup> THWN GROUND WIRE	IN 32mm <sup>9</sup> PVC PIPE
3	LPPC-DEPED DPWH	230	7600	33.04	60	2-14.0mm <sup>2</sup> THWN COPPER WIRE 1-5.5mm <sup>2</sup> THWN GROUND WIRE	IN 32mm <sup>9</sup> PVC PIPE
4	LPPD-DEPED DPWH	230	7600	33.04	60	2-14.0mm <sup>2</sup> THWN COPPER WIRE 1-5.5mm <sup>2</sup> THWN GROUND WIRE	IN 32mm <sup>9</sup> PVC PIPE
			35400	153.91			

**COMPUTATION :**

$$IT = \frac{35400 VA}{230 V}$$

$$IT = 153.91 AMP.$$

**OVER CURRENT PROTECTION**

USE : 200AT, 2P, 230V MOULDED CASE CIRCUIT BREAKER IN NEMA 1

**MAIN FEEDER :**

USE : 2 - 80.0mm<sup>2</sup> THWN & 1-22mm<sup>2</sup> THWN GROUND WIRE IN 63mm<sup>9</sup> PVC PIPE / 50mm<sup>9</sup> IMC PIPE

**MAIN DISTRIBUTION PANEL - MDP**

LOCATION: SERVICE ENTRANCE

MOUNTING: NEMA 3R, SURFACE MOUNTED WITH GRAY POWDERED COATED FINISH WITH MULTI-TERMINAL BLOCK FOR SOLID GROUND BUS

CKT. NO.	LOAD DESCRIPTION	VOLTS	VA	AMPERE LOAD			AT	SIZE OF	
				AB	BC	CA		WIRES	CONDUITS
1	DP-DEPED A	230	20,380			107.00	200	2-80mm <sup>2</sup> THWN COPPER WIRE 1-22mm <sup>2</sup> TW GROUND WIRE	IN 63mm <sup>9</sup> PVC PIPE
2	DP-SC	230	12,600			54.59	100	2-30mm <sup>2</sup> THWN COPPER WIRE 1-8.0mm <sup>2</sup> TW GROUND WIRE	IN 40mm <sup>9</sup> PVC PIPE
3	LPP-ADMIN	230	20,530		93.51		100	2-30mm <sup>2</sup> THWN COPPER WIRE 1-8.0mm <sup>2</sup> TW GROUND WIRE	IN 40mm <sup>9</sup> PVC PIPE
4	DP-NEW DEPED	230	20,380			107.00	200	2-80mm <sup>2</sup> THWN COPPER WIRE 1-22mm <sup>2</sup> TW GROUND WIRE	IN 63mm <sup>9</sup> PVC PIPE
5	DP-DPWH	230	23,920	153.91			200	2-80mm <sup>2</sup> THWN COPPER WIRE 1-22mm <sup>2</sup> TW GROUND WIRE	IN 63mm <sup>9</sup> PVC PIPE
6	DP-SMF	230	6,760	29.38			50	2-14mm <sup>2</sup> THWN COPPER WIRE 1-3.5mm <sup>2</sup> TW GROUND WIRE	IN 32mm <sup>9</sup> PVC PIPE
7	DP-DELARMENTE		1,240			5.39	30	2-5.0mm <sup>2</sup> THWN COPPER WIRE 1-3.5mm <sup>2</sup> TW GROUND WIRE	IN 25mm <sup>9</sup> PVC PIPE
8									
			105,810	183.29	200.51	166.98			

**COMPUTATION :**

$$IT = 1.732 X [200.51A + (0.25*12A)]$$

$$IT = 352.49 AMPERES$$

**OVER CURRENT PROTECTION :**

USE : 400AT/500AF, 3P, 230V, MOULDED CASE CIRCUIT BREAKER IN NEMA 3R

**MAIN FEEDER :**

USE : 3 - 250.0mm<sup>2</sup> THWN & 1-50.0mm<sup>2</sup> THWN GROUND WIRE IN 100mm<sup>9</sup> IMC PIPE

**DISTRIBUTION FEEDER :**

USE : 3 - 125 mm<sup>2</sup> THWN IN FREE AIR

3-SPOOL SECONDARY RACK

OVAL EYEBOLT, 3/8" GALVANIZED

WEATHERHEAD SERVICE ENTRANCE CAP

CTC (PROVIDE MACHINE BOLT)

LINE PHASE CONDUCTOR  
(drip loop must be at least 1.5m)  
1 set of 3-250mm<sup>2</sup> THW WIRE  
1-50mm<sup>2</sup> BCW WIRE GRD  
1-90mm<sup>9</sup> IMC PIPE

LOAD PHASE CONDUCTOR  
(drip loop must be at least 1.5m)  
3-250mm<sup>2</sup> THW WIRE  
1-50mm<sup>2</sup> BCW WIRE GRD  
1-90mm<sup>9</sup> IMC PIPE  
CONNECTED TO 3-125mm<sup>2</sup> THW IN FREE AIR

CT-METERING

90mm<sup>9</sup> IMC PIPE

U-BOLT (every 2.5 ft)

MOULDED CASE CIRCUIT BREAKER  
400AT, 500AF, 230V, 60HZ,  
SERVICE PROTECTION IN  
"NEMA3R" ENCLOSURE  
(Provide additional terminal lugs and ample space for wire termination)

1-50MM<sup>2</sup> BCW, CADWELD ON  
1-20MM<sup>9</sup> GROUNDING ROD  
W/ CONNECTOR  
IN 300MM X 300MM GROUND WELL

2-20MM<sup>9</sup> GROUNDING ROD  
W/ CONNECTOR

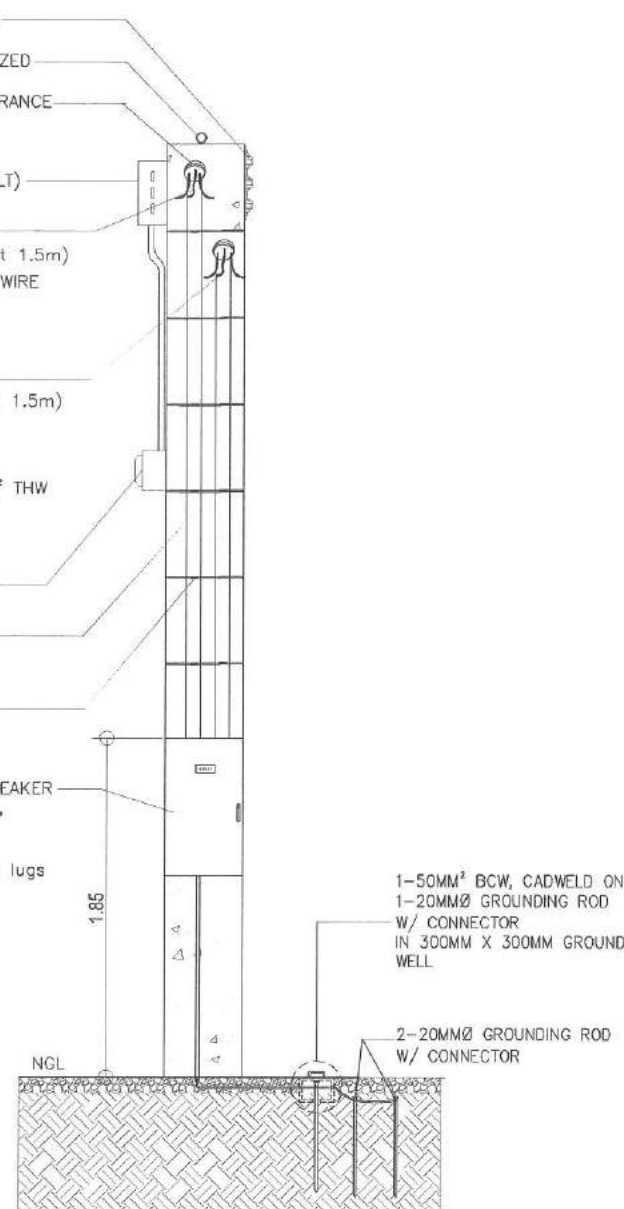

**1 SCHEDULE OF LOADS**

NOT TO SCALE

**2 SERVICE ENTRANCE DETAIL**

NOT TO SCALE



Republika ng Pilipinas  
Lungsod ng Quezon  
**CITY ENGINEERING DEPARTMENT**

PROJECT TITLE :

**PROPOSED REHABILITATION OF  
ELECTRICAL SYSTEM AT DEMETRIO TUAZON  
ELEMENTARY SCHOOL**

LOCATION: BARANGAY LOURDES, DISTRICT 1, QUEZON CITY

DRAWN BY: *[Signature]*

DATE: 11/19/2020

CHECKED BY: *[Signature]*

REVISION NO.:

SUBMITTED BY:

*[Signature]*

**ENGR. LEO S. DEL ROSARIO**  
HEAD, PLANNING & PROGRAMMING DIVISION

RECOMMENDING APPROVAL:

*[Signature]*

**ENGR. ISABANI R. VERZOSA, JR.**  
CIC, CITY ENGINEERING DEPARTMENT

APPROVED BY:

*[Signature]*

**HON. MA. JOSEFINA G. BELMONTE**  
CITY MAYOR, QUEZON CITY

SHEET CONTENT

SCHEDULE OF LOADS  
SERVICE ENTRANCE DETAIL

SHEET NO.

**EL  
06**



**GENERAL NOTES:**

**NOTES ON REINFORCEMENT:**

- ALL MATERIALS AND WORKMANSHIP SHALL CONFORM WITH THE LATEST BUILDING CODE OF AMERICAN CONCRETE INSTITUTE (ACI-318)
- ALL CONCRETE SHALL DEVELOP A MINIMUM COMPRESSIVE STRENGTH AT THE END OF TWENTY EIGHT (28) DAYS WITH CORRESPONDING MAXIMUM SIZE AGGREGATE AND SLUMPS AS FOLLOWS:
 

LOCATION	STRENGTH	MAX. SIZE OF AGGREGATES	MAX SLUMP
a. SLAB ON GRADE, CURBS, PAVEMENTS, WALL FOOTING	3000 Psi (20.685 MPA)	1 in (25 mm)	4 in (100mm)
b. BEAMS, COLUMNS, FOOTINGS SUSPENDED SLAB	3000 Psi (20.685 MPA)	¾ in (19mm)	4 in (100mm)
- ALL REINFORCING BARS SHALL CONFORM TO PHS49 GRADE 275 FOR 12MM AND SMALLER BARS AND GRADE 415 FOR 16mm AND LARGER BARS.
- IN GENERAL, THE LATEST EDITION OF ACI'S, MANUAL OF STANDARD PRACTICE DETAILING REINFORCED CONCRETE STRUCTURES SHALL BE ADHERED TO UNLESS OTHERWISE SHOWN OR NOTED.
- MAINTAIN MINIMUM CONCRETE COVER FOR REINFORCING STEEL AS FOLLOWS:
 

CONCRETE DEPOSITED DIRECTLY AGAINST GROUND	SLAB ON GRADE	WALLS ABOVE GRADE	BEAMS & COLUMNS
75mm	20mm	25mm	40mm
- SPLICES SHALL BE SECURELY WIRED TOGETHER AND SHALL LAP OR EXTEND IN ACCORDANCE WITH TABLE 1 (TABLE OF LAP SPICE AND ANCHORAGE LENGTH UNLESS OTHERWISE SHOWN ON DRAWINGS SPICES SHALL BE STAGGERED WHENEVER POSSIBLE.)
- ALL ANCHOR BOLTS, DOWELS AND OTHER INSERTS SHALL BE PROPERLY POSITIONED AND SECURED IN PLACE PRIOR TO PLACING OF CONCRETE.
- CONTRACTOR SHALL NOTE AND PROVIDE ALL MISCELLANEOUS CURBS SILLS STOOLS, EQUIPMENTS, AND MECHANICAL BASES THAT ARE REQUIRED BY THE ARCHITECTURAL, ELECTRICAL, AND MECHANICAL DRAWINGS.
- ALL CONCRETE SHALL BE KEPT MOIST FOR A MINIMUM OF SEVEN (7) CONSECUTIVE DAYS IMMEDIATELY AFTER POURING BY THE USE OF WET BURLAP, FOG SPRAYING, CURING COMPOUNDS OR OTHER APPROVED METHODS.
- STRIPPING OF FORMS AND SHORES:
 

FOUNDATION	24 HRS.
SUSPENDED SLAB EXCEPT WHEN ADDITIONAL LOADS ARE IMPOSED	8 DAYS
WALL	21 DAYS
BEAMS	14 DAYS
COLUMNS	21 DAYS
- DEVELOPMENT LENGTH FOR ALL BARS SHALL BE A MINIMUM OF 50 BAR DIAMETER UNLESS OTHERWISE NOTED STRUCTURAL STEEL AND PLATES.
- ALL STRUCTURAL STEEL SHALL CONFORM TO ASTM (A-36) SPECIFICATIONS WITH MINIMUM YIELD STRENGTH,  $f_y = 250$  MPa
- ANCHOR & FASTENER BOLTS. ALL BOLTS SHALL CONFORM TO ASTM (A-307) SPECIFICATIONS
- WELDING RODS. ALL WELDING RODS SHALL BE MILD STEEL ELECTRODE LOW HYDROGEN E7018 WITH MINIMUM YIELD STRENGTH = 420 MPa
- FOUNDATION IS DESIGNED BASED ON NATIONAL BUILDING CODE OF THE PHILIPPINES FOR AN ALLOWABLE SOIL BEARING CAPACITY OF 240Kpa
- FOUNDATION SHALL REST ON NATURAL SOIL UNLESS OTHERWISE NOTED BY THE ENGINEER. NO PART OF THE FOUNDATION SHALL REST ON FILL
- THE CONTRACTOR SHALL NOTIFY THE ENGINEER UPON COMPLETION OF FOUNDATION EXCAVATION FOR ACTUAL SOIL CONDITIONS WHICH DO NOT CONFORM TO THE BOA BEARING CAPACITY FOR PROPER REVISION.

**NOTES ON MASONRY WALLS**

- ALL MATERIALS WORKMANSHIP SHALL BE IN ACCORDANCE W/ THE APPLICABLE STANDARD & SPECIFICATIONS OF THE STRUCTURAL CODE OF THE PHILIPPINES & UNIFORM BUILDING CODE.
- MORTAR & GROUT FOR ALL CONCRETE MASONRY SHALL CONFORM TO ASTM 270 - TYPE N & SHALL HAVE A MINIMUM OF 28 DAYS STANDARD CYLINDER COMPRESSIVE STRENGTH OF 17.5MPa (2500 PSI)
- ALL CHB SHALL BE Laid OUT WITH CELLS IN UNOBSTRUCTED VERTICAL CONTINUITY.
- ALL CELLS ESPECIALLY THOSE WITH REINFORCEMENT SHALL BE FILLED WITH MORTAR.
- ALL MASONRY WALLS SHALL BE PROVIDED W STIFFENED BEAM BLOCK & STIFFENER AS REQUIRED
  - FOR HIGH WALLS 1 EVERY 3000MM & COLUMN (BOLT) AT 3000 mm ON CENTER
  - FOR DOORS & WINDOWS OPENING PROVIDE LINTEL BEAM SAME AS STIFFENER BEAM BLOCK.
- UNLESS OTHERWISE SHOWN IN PLANS, ALL CONCRETE HOLLOW BLOCK AND CERAMIC BLOCKS SHALL BE REINFORCED AS SHOWN IN THE SCHEDULE OF CONCRETE HOLLOW BLOCKS AND CERAMIC BLOCK REINFORCEMENT.

**FOUNDATION**

BLOCK THICKNESS	SCHEDULE OF CONCRETE HOLLOW BLOCK AND CERAMIC BLOCK REINFORCEMENT		NOTES
	HORIZONTAL	VERTICAL	
100 mm	10mm $\phi$ @ 600mm O.C.	10mm $\phi$ @ 600mm O.C.	A. MINIMUM LAP SPICE = 0.25m B. PROVIDE RIGHT ANGLED REINFORCEMENT AT CORNERS 0.92m LONG C. WHERE CHB OR CER. BLK. WALL DOWELS JOIN COL., R.C. BEAMS AND WALL DOWELS WITH THE SAME SIZE AS VERT. OR HOR. REINFORCEMENTS SHALL BE PROVIDED.
150 mm	10mm $\phi$ @ 600mm O.C.	10mm $\phi$ @ 600mm O.C.	

**TESTING & COMMISSIONING WORKS:**

- ALL NECESSARY TESTING OF MATERIALS AND COMMISSIONING WORKS MUST BE PERFORMED AS PER STANDARD PROCEDURE.

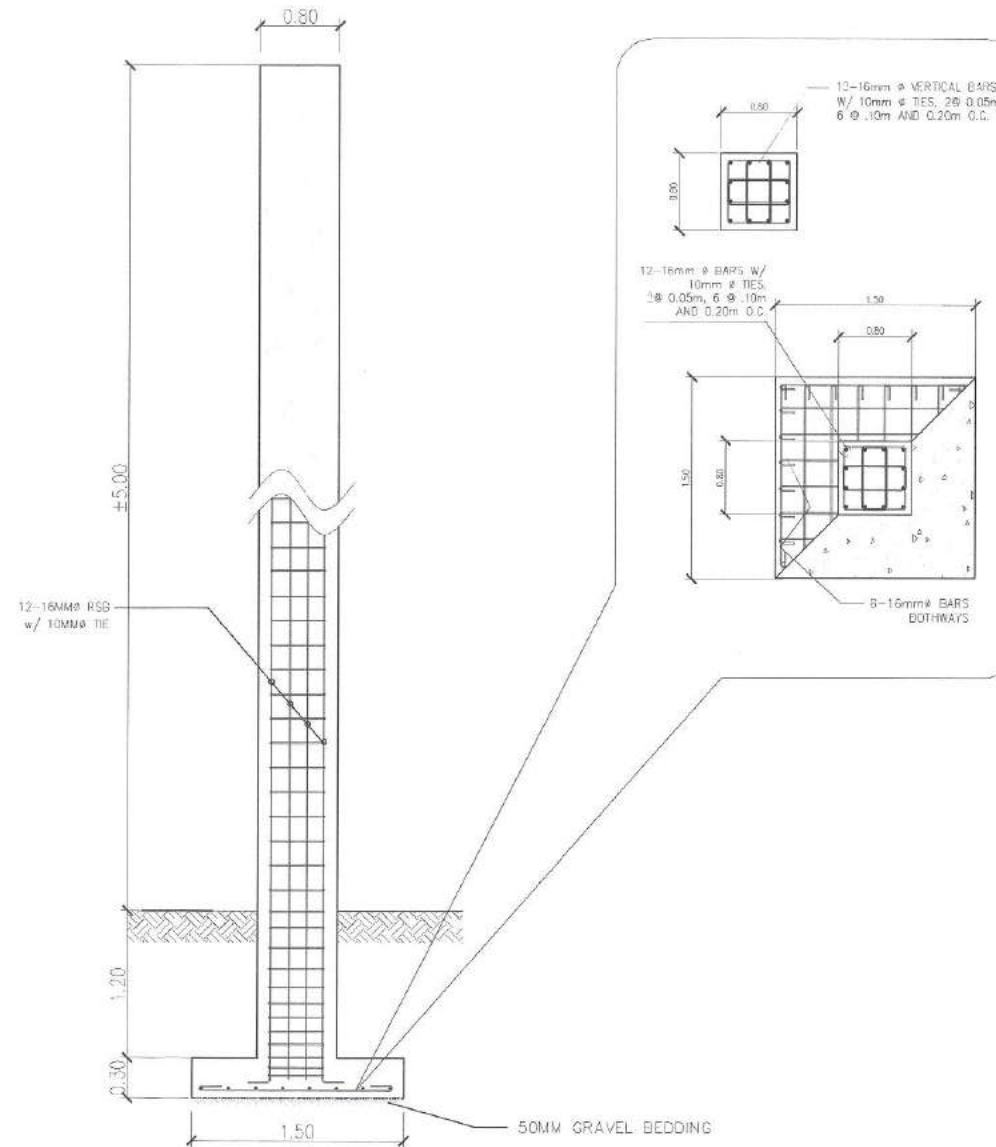

**1 GENERAL NOTES**

**2 SERVICE ENTRANCE CONCRETE POST DETAIL**

NOT TO SCALE



Republika ng Pilipinas  
Lungsod ng Quezon  
**CITY ENGINEERING DEPARTMENT**

PROJECT TITLE:  
**PROPOSED REHABILITATION OF ELECTRICAL SYSTEM AT DEMETRIO TUAZON ELEMENTARY SCHOOL**

LOCATION: BARANGAY LOURDES, DISTRICT 1, QUEZON CITY

DRAWN BY: *[Signature]*  
DATE: 11/19/2020  
CHECKED BY: *[Signature]*  
REVISION NO.:

SUBMITTED BY:  
*[Signature]*  
**ENGR. LEO S. DEL ROSARIO**  
HEAD, PLANNING & PROGRAMMING DIVISION

RECOMMENDING APPROVAL:  
*[Signature]*  
**ENGR. SAGINI R. VERZOSA, JR.**  
CITY ENGINEERING DEPARTMENT

APPROVED BY:  
*[Signature]*  
**HON. MA. JOSEFINA G. BELMONTE**  
CITY MAYOR, QUEZON CITY

SHEET CONTENT  
GENERAL NOTES  
SERVICE ENTRANCE  
CONCRETE POST DETAIL

SHEET NO.  
**CW 01**

## *Section VIII. Bill of Quantities*

### **Notes on the Bill of Quantities**

#### **Objectives**

The objectives of the Bill of Quantities are:

- a. to provide sufficient information on the quantities of Works to be performed to enable Bids to be prepared efficiently and accurately; and
- b. when a Contract has been entered into, to provide a priced Bill of Quantities for use in the periodic valuation of Works executed.

In order to attain these objectives, Works should be itemized in the Bill of Quantities in sufficient detail to distinguish between the different classes of Works, or between Works of the same nature carried out in different locations or in other circumstances which may give rise to different considerations of cost. Consistent with these requirements, the layout and content of the Bill of Quantities should be as simple and brief as possible.

#### **Daywork Schedule**

A Daywork Schedule should be included only if the probability of unforeseen work, outside the items included in the Bill of Quantities, is high. To facilitate checking by the Entity of the realism of rates quoted by the Bidders, the Daywork Schedule should normally comprise the following:

- a. A list of the various classes of labor, materials, and Constructional Plant for which basic daywork rates or prices are to be inserted by the Bidder, together with a statement of the conditions under which the Contractor will be paid for work executed on a daywork basis.
- b. Nominal quantities for each item of Daywork, to be priced by each Bidder at Daywork rates as Bid. The rate to be entered by the Bidder against each basic Daywork item should include the Contractor's profit, overheads, supervision, and other charges.

#### **Provisional Sums**

A general provision for physical contingencies (quantity overruns) may be made by including a provisional sum in the Summary Bill of Quantities. Similarly, a contingency allowance for possible price increases should be provided as a provisional sum in the Summary Bill of Quantities. The inclusion of such provisional sums often facilitates budgetary approval by avoiding the need to request periodic supplementary approvals as the future need arises. Where such provisional sums or contingency allowances are used, the SCC should state the manner in which they will be used, and under whose authority (usually the Procuring Entity's Representative's).

The estimated cost of specialized work to be carried out, or of special goods to be supplied, by other contractors should be indicated in the relevant part of the Bill of Quantities as a particular provisional sum with an appropriate brief description. A separate procurement procedure is normally carried out by the Procuring Entity to select such specialized contractors. To provide an element of competition among the Bidders in respect of any facilities, amenities, attendance, etc., to be provided by the successful Bidder as prime Contractor for the use and convenience of the specialist contractors, each related provisional sum should be followed by an item in the Bill of Quantities inviting the Bidder to quote a sum for such amenities, facilities, attendance, etc.

### **Signature Box**

A signature box shall be added at the bottom of each page of the Bill of Quantities where the authorized representative of the Bidder shall affix his signature. Failure of the authorized representative to sign each and every page of the Bill of Quantities shall be a cause for rejection of his bid.

These Notes for Preparing a Bill of Quantities are intended only as information for the Procuring Entity or the person drafting the Bidding Documents. They should not be included in the final documents.

**PROJECT TITLE :** PROPOSED REHABILITATION OF ELECTRICAL SYSTEM AT DEMETRIO  
TUAZON ELEMENTARY SCHOOL

**LOCATION :** BARANGAY LOURDES, DISTRICT 1, QUEZON CITY

**PROJECT NO. :** 21 - 00042

**DURATION :** Ninety (90) Calendar Days

***BREAKDOWN OF COST***

<b>ITEM NO</b>	<b>WORK DESCRIPTION</b>	<b>MATERIALS COST</b>	<b>LABOR COST</b>	<b>INDIRECT COST</b>	<b>AGGREGATE COST</b>
I	GENERAL REQUIREMENTS				
II	REHABILITATION OF LPP AT SMF BUILDING				
III	REHABILITATION OF LPP AT STAGE-COURT				
IV	REHABILITATION OF LPP AT ADMIN BUILDING				
V	UPGRADING OF MAIN ELECTRICAL SERVICE ENTRANCE AND DISTRIBUTION FEEDER				

**TOTAL COST** P \_\_\_\_\_

LUMP SUM BID IN WORDS : \_\_\_\_\_

\_\_\_\_\_

Contractor : \_\_\_\_\_

**BILL OF QUANTITIES**  
(Building Construction/Rehabilitation Project)

**PROJECT TITLE :** PROPOSED REHABILITATION OF ELECTRICAL SYSTEM AT DEMETRIO TUAZON ELEMENTARY SCHOOL

**LOCATION :** BARANGAY LOURDES, DISTRICT 1, QUEZON CITY

**PROJECT NO. :** 21 - 00042

**DURATION :** Ninety (90) Calendar Days

**SCOPE OF WORKS:**

- 1 General Requirements include temporary facilities and utilities, billboard, scaffolding and construction health and safety.
- 2 Clearing, hauling and disposal of construction materials and debris.
- 3 Installation of roughing-ins, electrical wirings, devices, and fixtures.
- 4 Installation of panelboard and accessories.
- 5 Construction of concrete service entrance post.
- 6 All necessary testing of materials and commissioning works must be performed as per standard procedure.

ITEM NO	WORK DESCRIPTION AND SCOPE OF WORKS	QTY	UNIT	UNIT COST	TOTAL COST
<b>I</b>	<b>GENERAL REQUIREMENTS</b>				
	Billboard	1	pc	P	P
	Clearing, Hauling and Disposal of Construction	1	t.l.		
	Construction Health and Safety	1	unit		
	Scaffolding (Rental)	9	sq.m.		
	Temporary Electrical and Water Facilities	90	day		
	Temporary Enclosure Around the Construction Area (H=2.4m)	12	l.m.		
				<b>Direct Cost I</b>	<b>P</b>
<b>II</b>	<b>REHABILITATION OF LPP AT SMF BUILDING</b>				
<b>A</b>	<b>SITE WORKS</b>				
	Chipping of CHB Wall	1	sq.m.	P	P
				Direct Cost A	P
<b>B</b>	<b>CIVIL WORKS / STRUCTURAL WORKS</b>				
	Concrete Works				
	25mm Concrete Topping (Panelboards, Power Layout)	1	sq.m.	P	P
				Material Cost B	P
				Labor Cost B	
				Direct Cost B	P
<b>C</b>	<b>ARCHITECTURAL WORKS</b>				
	Flat Latex Paint Finish	1	sq.m.	P	P
	Epoxy Enamel Paint Finish (Electrical Works)	1	sq.m		
				Material Cost C	P

ITEM NO	WORK DESCRIPTION AND SCOPE OF WORKS	QTY	UNIT	UNIT COST	TOTAL COST
				Labor Cost C	
				Direct Cost C	P

ITEM NO	WORK DESCRIPTION AND SCOPE OF WORKS	QTY	UNIT	UNIT COST	TOTAL COST
<b>D</b>	<b>ELECTRICAL WORKS</b>				
1	Roughing-ins				
	25mmØ IMC Pipe	15	pcs	P	P
	Fittings and Accessories				
	25mmØ IMC Coupling	17	pcs		
	25mmØ IMC Elbow	6	pcs		
	25mmØ IMC Locknut & Bushing	34	pairs		
	20mm Ø x 3000mm Grounding Rod (Copper Clod) w/ Ground Clamp	1	set		
2	Wires and Cables				
	5.5mm <sup>2</sup> THHN Wire	1	rolls		
	14mm <sup>2</sup> THHN Wire	20	l.m.		
5	Panelboard				
	DP-SMF				
	Main: 50AT, 100AF, 2P, 230V, 10 KAIC, MCCB	1	assy		
	Branches: 2 - 40AT, 100AF, 2P, 230V, MCCB				
	Enclosure: NEMA 3R with Ground Terminals				
6	Pipe Hangers & Supports				
	Horizontal layout of pipe	30	l.m.		
	Vertical layout of pipe	3	l.m.		
7	Miscellaneous & Consumables				
	#16 G.I. Tie Wire (for cable pulling)	1	kg		
	Electrical Tape	2	rolls		
	Masking Tape	1	roll		
	Pulling Lubricant	1	can		
	Rubber Tape	1	roll		
				Materials Cost D	P
				Labor Cost D	
				Direct Cost D	P
				<b>Materials Cost II</b>	<b>P</b>
				<b>Labor Cost II</b>	
				<b>Direct Cost II</b>	<b>P</b>
<b>III</b>	<b>REHABILITATION OF LPP AT STAGE-COURT</b>				
<b>A</b>	<b>SITE WORKS</b>				
	Chipping of CHB Wall	1	sq.m.	P	P
				Direct Cost A	P
<b>B</b>	<b>CIVIL WORKS / STRUCTURAL WORKS</b>				
	Concrete Works				
	25mm Concrete Topping (Panelboard)	1	sq.m.	P	P
				Material Cost B	P
				Labor Cost B	
				Direct Cost B	P

ITEM NO	WORK DESCRIPTION AND SCOPE OF WORKS	QTY	UNIT	UNIT COST	TOTAL COST
<b>C</b>	<b>ARCHITECTURAL WORKS</b>				
	Flat Latex Paint Finish	1	sq.m	P	P
	Epoxy Enamel Paint Finish (Electrical Works)	1	sq.m		
				Material Cost C	P
				Labor Cost C	
				Direct Cost C	P



ITEM NO	WORK DESCRIPTION AND SCOPE OF WORKS	QTY	UNIT	UNIT COST	TOTAL COST
<b>D</b>	<b>ELECTRICAL WORKS</b>				
1	Roughing-ins				
	32mmØ IMC Pipe	5	pcs	P	P
	Fittings and Accessories				
	32mmØ IMC Coupling	7	pcs		
	32mmØ IMC Elbow	8	pcs		
	32mmØ IMC Locknut & Bushing	14	pairs		
	20mm Ø x 3000mm Grounding Rod (Copper Clod) w/ Ground Clamp	1	set		
2	Wires and Cables				
	3.5mm² THHN Wire	1	rolls		
	30mm² THHN Wire	20	l.m.		
	8.0mm² TW Wire	10	l.m.		
3	Panelboard				
	DP-SC				
	Main: 100AT, 100AF, 2P, 230V, 10 KAIC, MCCB Branches: 2 - 40AT, 100AF, 2P, 230V, MCCB 2 - 20AT, 100AF, 2P, 230V, MCCB Enclosure: NEMA 1 with Ground Terminals	1	assy		
4	Pipe Hangers & Supports				
	Horizontal layout of pipe	10	l.m.		
	Vertical layout of pipe	3	l.m.		
5	Miscellaneous & Consumables				
	#16 G.I. Tie Wire (for cable pulling)	1	kg		
	Electrical Tape	2	rolls		
	Masking Tape	1	roll		
	Pulling Lubricant	1	can		
	Rubber Tape	1	roll		
				Materials Cost D	P
				Labor Cost D	
				Direct Cost D	P
				<b>Materials Cost III</b>	<b>P</b>
				<b>Labor Cost III</b>	
				<b>Direct Cost III</b>	<b>P</b>
<b>IV</b>	<b>REHABILITATION OF LPP AT ADMIN BUILDING</b>				
<b>A</b>	<b>SITE WORKS</b>				
	Chipping of CHB Wall	1	sq.m.	P	P
	Demolition Works				
	Dismantling of Existing LPP-Admin	1	assy		
				Direct Cost A	P
<b>B</b>	<b>CIVIL WORKS / STRUCTURAL WORKS</b>				

ITEM NO	WORK DESCRIPTION AND SCOPE OF WORKS	QTY	UNIT	UNIT COST	TOTAL COST
	Concrete Works				
	25mm Concrete Topping (Panelboard)	1	sq.m.	P	P
				Material Cost B	P
				Labor Cost B	
				Direct Cost B	P

ITEM NO	WORK DESCRIPTION AND SCOPE OF WORKS	QTY	UNIT	UNIT COST	TOTAL COST
<b>C</b>	<b>ARCHITECTURAL WORKS</b>				
	Flat Latex Paint Finish	8	sq.m	P	P
	Epoxy Enamel Paint Finish (Electrical Works)	1	sq.m		
				Material Cost C	P
				Labor Cost C	
				Direct Cost C	P
<b>D</b>	<b>ELECTRICAL WORKS</b>				
1	Roughing-ins				
	32mmØ IMC Pipe	2	pcs		
	Fittings and Accessories				
	32mmØ IMC Coupling	1	pcs		
	32mmØ IMC Elbow	1	pcs		
	32mmØ IMC Locknut & Bushing	2	pairs		
	32mmØ Weatherproof Entrance Cap	1	pc		
2	Wires and Cables				
	30mm² THHN Wire	120	l.m.		
	8.0mm² TW Wire	60	l.m.		
3	Panelboard				
	LPP-ADMIN				
	Main: 100AT, 100AF, 2P, 230V, 10 KAIC, MCCB  Branches: 13 - 20AT, 100AF, 2P, 230V, MCCB 1 - 30AT, 100AF, 2P, 230V, MCCB  Enclosure: NEMA 1 with Ground Terminals	1	assy		
4	Pipe Hangers & Supports				
	Horizontal layout of pipe	10	l.m.		
	Vertical layout of pipe	3	l.m.		
5	Miscellaneous & Consumables				
	#16 G.I. Tie Wire (for cable pulling)	1	kg		
	Electrical Tape	2	rolls		
	Masking Tape	1	roll		
	Pulling Lubricant	1	can		
	Rubber Tape	1	roll		
				Materials Cost D	P
				Labor Cost D	
				Direct Cost D	P
				<b>Materials Cost IV</b>	<b>P</b>
				<b>Labor Cost IV</b>	
				<b>Direct Cost IV</b>	<b>P</b>
<b>V</b>	<b>UPGRADING OF MAIN ELECTRICAL SERVICE ENTRANCE AND DISTRIBUTION FEEDER</b>				

ITEM NO	WORK DESCRIPTION AND SCOPE OF WORKS	QTY	UNIT	UNIT COST	TOTAL COST
<b>A</b>	<b>SITE WORKS</b>				
1	Demolition Works				
	Dismantling of existing 100mm <sup>2</sup> THWN Wire	200	l.m.	P	P
	Dismantling of existing Main Circuit Breaker	1	assy		
2	Site Clearing and Preparation	4	sq.m.		
3	Layout and Staking	4	sq.m.		
4	Excavation(Solid rock adobe)				
	Footing	5	cu.m.		
				Subtotal 1-4	P
5	Soil Treatment	3	sq.m.	P	
6	Gravel Bedding	1	cu.m.		P
				Material Cost 5-6	P
				Labor Cost 5-6	
				Direct Cost 5-6	P
7	Backfill and Compaction	3	sq.m.		
				Subtotal 7	P
				Material Cost A	P
				Labor Cost A	
				Direct Cost A	P
<b>B</b>	<b>CIVIL WORKS / STRUCTURAL WORKS</b>				
	Concrete Works				
	On Site Mix Concrete				
	Earth Pit for Electrical Grounding system	1	cu.m	P	
	Footing	1	cu.m		
	Column	5	cu.m		
	Reinforcing Steel Bars				
	Grade 40 Reinforcing Steel Bars W/ Ga.16 Tie Wire				
	10mmØ Earthpit for Electrical Grounding system	8	kg		
	10mmØ Column	175	kg		
	Grade 60 Reinforcing Steel Bars W/ Ga.16 Tie Wire				
	16mmØ Footing	60	kg		
	16mmØ Column	140	kg		
	Formworks				
	Earth Pit for Electrical Grounding system	1	sq.m		
	Column	11	sq.m		
	Scaffoldings & Shoring				
	Column	7	l.m.		
				Material Cost B	P
				Labor Cost B	
				Direct Cost B	P
<b>C</b>	<b>ARCHITECTURAL WORKS</b>				

ITEM NO	WORK DESCRIPTION AND SCOPE OF WORKS	QTY	UNIT	UNIT COST	TOTAL COST
	Epoxy Enamel Paint Finish (Electrical Works)	2	sq.m	P	P
				Material Cost C	P
				Labor Cost C	
				Direct Cost C	P
<b>D</b>	<b>ELECTRICAL WORKS</b>				
1	Roughing-ins				
	90mmØ IMC Pipe	10	pcs		
	Fittings and Accessories				
	90mmØ IMC Coupling	15	pcs		
	90mmØ IMC Elbow	3	pcs		
	90mmØ IMC Locknut & Bushing	6	pairs		
	90mmØ Weatherproof Entrance Cap	3	pcs		
	80mmØ Solderless Connector (Claw Type)	6	pcs		
	125mmØ Solderless Connector (Claw Type)	14	pcs		
	Secondary Rack w/ 3 spool, Heavy duty	10	pcs		
	20mm Ø x 3000mm Grounding Rod (Copper Clod w/ Ground Clamp	3	sets		

ITEM NO	WORK DESCRIPTION AND SCOPE OF WORKS	QTY	UNIT	UNIT COST	TOTAL COST
2	Wires and Cables				
	50mm <sup>2</sup> Bare Copper Wire	5	l.m.		
	5.5mm <sup>2</sup> THHN Wire	1	roll		
	22mm <sup>2</sup> THHN Wire	20	l.m.		
	50mm <sup>2</sup> THHN Wire	5	l.m.		
	80mm <sup>2</sup> THW Wire	210	l.m.		
	125mm <sup>2</sup> THW Wire	600	l.m.		
	250mm <sup>2</sup> THW Wire	21	l.m.		
3	Panelboard				
	Main Distribution Panel				
	Main: 400AT, 500AF, 3P, 230V, 18 KAIC, MCCB Enclosure: NEMA 3R with Ground Terminals	1	assy		
6	Pipe Hangers & Supports				
	Horizontal layout of pipe	15	l.m.		
	Vertical layout of pipe	15	l.m.		
7	Miscellaneous & Consumables				
	10mmØ Nylon Gray	30	lm		
	#16 G.I. Tie Wire (for cable pulling)	1	kg		
	Cadweld powder, No. 150	1	pack		
	Electrical Tape	2	rolls		
	Epoxy Enamel Paint Finish (Electrical Works)	1	sq.m		
	Masking Tape	1	roll		
	Pulling Lubricant	1	can		
	Rubber Tape	1	roll		
				Materials Cost D	P
				Labor Cost D	
				Direct Cost D	P
				Materials Cost V	P
				Labor Cost V	
				Direct Cost V	P

### SUMMARY

ITEM NO	WORK DESCRIPTION & SCOPE OF WORKS	TOTAL COST
I	GENERAL REQUIREMENTS	P
II	REHABILITATION OF LPP AT SMF BUILDING	
III	REHABILITATION OF LPP AT STAGE-COURT	
IV	REHABILITATION OF LPP AT ADMIN BUILDING	

ITEM NO	WORK DESCRIPTION AND SCOPE OF WORKS	QTY	UNIT	UNIT COST	TOTAL COST
V	UPGRADING OF MAIN ELECTRICAL SERVICE ENTRANCE AND DISTRIBUTION FEEDER				
<b>TOTAL DIRECT COST</b> Overhead, Contingencies and Miscellaneous Expenses (OCM) Profit VAT					<b>P</b>
<b>TOTAL ESTIMATED COST</b>					<b>P</b>

## ***Section IX. Checklist of Technical and Financial Documents***

### **Notes on the Checklist of Technical and Financial Documents**

The prescribed documents in the checklist are mandatory to be submitted in the Bid, but shall be subject to the following:

- a. GPPB Resolution No. 09-2020 on the efficient procurement measures during a State of Calamity or other similar issuances that shall allow the use of alternate documents in lieu of the mandated requirements; or
- b. any subsequent GPPB issuances adjusting the documentary requirements after the effectivity of the adoption of the PBDs.

The BAC shall be checking the submitted documents of each Bidder against this checklist to ascertain if they are all present, using a non-discretionary “pass/fail” criterion pursuant to Section 30 of the 2016 revised IRR of RA No. 9184.



# Checklist of Technical and Financial Documents

## I. TECHNICAL COMPONENT ENVELOPE

### *Class “A” Documents*

#### Legal Documents

- (a) Valid PhilGEPS Registration Certificate (Platinum Membership) (all pages);  
**and**
- (b) Registration certificate from Securities and Exchange Commission (SEC), Department of Trade and Industry (DTI) for sole proprietorship, or Cooperative Development Authority (CDA) for cooperatives or its equivalent document;  
**and**
- (c) Mayor’s or Business permit issued by the city or municipality where the principal place of business of the prospective bidder is located, or the equivalent document for Exclusive Economic Zones or Areas;  
**and**
- (e) Tax clearance per E.O. No. 398, s. 2005, as finally reviewed and approved by the Bureau of Internal Revenue (BIR).

#### Technical Documents

- (f) Statement of the prospective bidder of all its ongoing government and private contracts, including contracts awarded but not yet started, if any, whether similar or not similar in nature and complexity to the contract to be bid (*please see attached prescribed forms required by the QC – BAC for Infrastructure and Consultancy*); **and**
- (g) Statement of the bidder’s Single Largest Completed Contract (SLCC) similar to the contract to be bid, except under conditions provided under the rules with an attached Notice of Award, Notice to Proceed, Contract and Certificate of Acceptance (*please see attached prescribed form required by the QC – BAC for Infrastructure and Consultancy*); **and**
- (h) Philippine Contractors Accreditation Board (PCAB) License;  
**or**  
Special PCAB License in case of Joint Ventures;  
**and** registration for the type and cost of the contract to be bid; **and**
- (i) Original copy of Bid Security. If in the form of a Surety Bond, submit also a certification issued by the Insurance Commission;  
**or**  
Original copy of Notarized Bid Securing Declaration; **and**
- (j) Project Requirements, which shall include the following:
  - a. Organizational chart for the contract to be bid;
  - b. List of contractor’s key personnel (*e.g.*, Project Manager, Project Engineers, Materials Engineers, and Foremen), to be assigned to the contract to be bid, with their complete qualification and experience data (*please see attached prescribed form required by the QC – BAC for Infrastructure and Consultancy*);
  - c. List of contractor’s major equipment units, which are owned, leased, and/or under purchase agreements, supported by proof of ownership or certification of availability of equipment from the equipment

lessor/vendor for the duration of the project, as the case may be (*please see attached prescribed form required by the QC – BAC for Infrastructure and Consultancy*); **and**

- (k) Original duly signed Omnibus Sworn Statement (OSS); **and** if applicable, Original Notarized Secretary's Certificate in case of a corporation, partnership, or cooperative; or Original Special Power of Attorney of all members of the joint venture giving full power and authority to its officer to sign the OSS and do acts to represent the Bidder.

Additional Technical Requirements:

- Certificate of Site Inspection or Affidavit of Site Inspection as part of Omnibus Sworn Statement
- Affidavit of Undertaking for Key Personnel and Equipment (*please see attached prescribed form required by the QC – BAC for Infrastructure and Consultancy*)
- Equipment Utilization Schedule
- Manpower Schedule
- Construction Schedule and S-Curve
- PERT-CMP
- Construction Methods

#### Financial Documents

- (l) The prospective bidder's audited financial statements, showing, among others, the prospective bidder's total and current assets and liabilities, stamped "received" by the BIR or its duly accredited and authorized institutions, for the preceding calendar year which should not be earlier than two (2) years from the date of bid submission; **and**
- (m) The prospective bidder's computation of Net Financial Contracting Capacity (NFCC) (*please see attached prescribed form required by the QC – BAC for Infrastructure and Consultancy*).

#### **Class "B" Documents**

- (n) If applicable, duly signed joint venture agreement (JVA) in accordance with RA No. 4566 and its IRR in case the joint venture is already in existence; **or** duly notarized statements from all the potential joint venture partners stating that they will enter into and abide by the provisions of the JVA in the instance that the bid is successful.

## **II. FINANCIAL COMPONENT ENVELOPE**

- (o) Original of duly signed and accomplished Financial Bid Form; **and**

#### Other documentary requirements under RA No. 9184

- (p) Original of duly signed Bid Prices in the Bill of Quantities; **and**
- (q) Duly accomplished Detailed Estimates Form, including a summary sheet indicating the unit prices of construction materials, labor rates, and equipment rentals used in coming up with the Bid; **and**
- (r) Cash Flow by Quarter.

**Bid Form for the Procurement of Infrastructure Projects**  
*[shall be submitted with the Bid]*

---

**BID FORM**

Date : \_\_\_\_\_  
Project Identification No. : \_\_\_\_\_

To: *[name and address of Procuring Entity]*

Having examined the Philippine Bidding Documents (PBDs) including the Supplemental or Bid Bulletin Numbers *[insert numbers]*, the receipt of which is hereby duly acknowledged, we, the undersigned, declare that:

- a. We have no reservation to the PBDs, including the Supplemental or Bid Bulletins, for the Procurement Project: *[insert name of contract]*;
- b. We offer to execute the Works for this Contract in accordance with the PBDs;
- c. The total price of our Bid in words and figures, excluding any discounts offered below is: *[insert information]*;
- d. The discounts offered and the methodology for their application are: *[insert information]*;
- e. The total bid price includes the cost of all taxes, such as, but not limited to: *[specify the applicable taxes, e.g. (i) value added tax (VAT), (ii) income tax, (iii) local taxes, and (iv) other fiscal levies and duties]*, which are itemized herein and reflected in the detailed estimates,
- f. Our Bid shall be valid within the a period stated in the PBDs, and it shall remain binding upon us at any time before the expiration of that period;
- g. If our Bid is accepted, we commit to obtain a Performance Security in the amount of *[insert percentage amount]* percent of the Contract Price for the due performance of the Contract, or a Performance Securing Declaration in lieu of the the allowable forms of Performance Security, subject to the terms and conditions of issued GPPB guidelines<sup>1</sup> for this purpose;
- h. We are not participating, as Bidders, in more than one Bid in this bidding process, other than alternative offers in accordance with the Bidding Documents;
- i. We understand that this Bid, together with your written acceptance thereof included in your notification of award, shall constitute a binding contract between us, until a formal Contract is prepared and executed; and
- j. We understand that you are not bound to accept the Lowest Calculated Bid or any other Bid that you may receive.

---

<sup>1</sup> currently based on GPPB Resolution No. 09-2020

- k. We likewise certify/confirm that the undersigned, is the duly authorized representative of the bidder, and granted full power and authority to do, execute and perform any and all acts necessary to participate, submit the bid, and to sign and execute the ensuing contract for the [Name of Project] of the [Name of the Procuring Entity].
- l. We acknowledge that failure to sign each and every page of this Bid Form, including the Bill of Quantities, shall be a ground for the rejection of our bid.

Name: \_\_\_\_\_

Legal Capacity: \_\_\_\_\_

Signature: \_\_\_\_\_

Duly authorized to sign the Bid for and behalf of: \_\_\_\_\_

Date: \_\_\_\_\_

## **Bid Securing Declaration Form**

*[shall be submitted with the Bid if bidder opts to provide this form of bid security]*

---

REPUBLIC OF THE PHILIPPINES)  
CITY OF \_\_\_\_\_) S.S.

### **BID SECURING DECLARATION** **Project Identification No.: *[Insert number]***

To: *[Insert name and address of the Procuring Entity]*

I/We, the undersigned, declare that:

1. I/We understand that, according to your conditions, bids must be supported by a Bid Security, which may be in the form of a Bid Securing Declaration.
2. I/We accept that: (a) I/we will be automatically disqualified from bidding for any procurement contract with any procuring entity for a period of two (2) years upon receipt of your Blacklisting Order; and, (b) I/we will pay the applicable fine provided under Section 6 of the Guidelines on the Use of Bid Securing Declaration, within fifteen (15) days from receipt of the written demand by the procuring entity for the commission of acts resulting to the enforcement of the bid securing declaration under Sections 23.1(b), 34.2, 40.1 and 69.1, except 69.1(f), of the IRR of RA No. 9184; without prejudice to other legal action the government may undertake.
3. I/We understand that this Bid Securing Declaration shall cease to be valid on the following circumstances:
  - a. Upon expiration of the bid validity period, or any extension thereof pursuant to your request;
  - b. I am/we are declared ineligible or post-disqualified upon receipt of your notice to such effect, and (i) I/we failed to timely file a request for reconsideration or (ii) I/we filed a waiver to avail of said right; and
  - c. I am/we are declared the bidder with the Lowest Calculated Responsive Bid, and I/we have furnished the performance security and signed the Contract.

IN WITNESS WHEREOF, I/We have hereunto set my/our hand/s this \_\_\_\_ day of *[month]* *[year]* at *[place of execution]*.

*[Insert NAME OF BIDDER OR ITS AUTHORIZED  
REPRESENTATIVE]*  
*[Insert signatory's legal capacity]*  
Affiant

#### **[Jurat]**

*[Format shall be based on the latest Rules on Notarial Practice]*

## **Contract Agreement Form for the Procurement of Infrastructure Projects (Revised)**

*[not required to be submitted with the Bid, but it shall be submitted within ten (10) days after receiving the Notice of Award]*

---

### **CONTRACT AGREEMENT**

THIS AGREEMENT, made this *[insert date]* day of *[insert month]*, *[insert year]* between *[name and address of PROCURING ENTITY]* (hereinafter called the "Entity") and *[name and address of Contractor]* (hereinafter called the "Contractor").

WHEREAS, the Entity is desirous that the Contractor execute *[name and identification number of contract]* (hereinafter called "the Works") and the Entity has accepted the Bid for *[contract price in words and figures in specified currency]* by the Contractor for the execution and completion of such Works and the remedying of any defects therein.

NOW THIS AGREEMENT WITNESSETH AS FOLLOWS:

1. In this Agreement, words and expressions shall have the same meanings as are respectively assigned to them in the Conditions of Contract hereinafter referred to.
2. The following documents as required by the 2016 revised Implementing Rules and Regulations of Republic Act No. 9184 shall be deemed to form and be read and construed as part of this Agreement, viz.:
  - a. Philippine Bidding Documents (PBDs);
    - i. Drawings/Plans;
    - ii. Specifications;
    - iii. Bill of Quantities;
    - iv. General and Special Conditions of Contract;
    - v. Supplemental or Bid Bulletins, if any;
  - b. Winning bidder's bid, including the Eligibility requirements, Technical and Financial Proposals, and all other documents or statements submitted;  
  
Bid form, including all the documents/statements contained in the Bidder's bidding envelopes, as annexes, and all other documents submitted (e.g., Bidder's response to request for clarifications on the bid), including corrections to the bid, if any, resulting from the Procuring Entity's bid evaluation;
  - c. Performance Security;
  - d. Notice of Award of Contract and the Bidder's conforme thereto; and
  - e. Other contract documents that may be required by existing laws and/or the Procuring Entity concerned in the PBDs. **Winning bidder agrees that additional contract documents or information prescribed by the GPPB that are subsequently required for submission after the contract execution, such as the Notice to Proceed, Variation Orders, and Warranty Security, shall likewise form part of the Contract.**
3. In consideration for the sum of *[total contract price in words and figures]* or such other sums as may be ascertained, *[Named of the bidder]* agrees to *[state the object of the contract]* in accordance with his/her/its Bid.

4. The *[Name of the procuring entity]* agrees to pay the above-mentioned sum in accordance with the terms of the Bidding.

IN WITNESS whereof the parties thereto have caused this Agreement to be executed the day and year first before written.

*[Insert Name and Signature] [Insert Name and Signature]*

*[Insert Signatory's Legal Capacity] [Insert Signatory's Legal Capacity]*

*for: for:*

*[Insert Procuring Entity] [Insert Name of Supplier]*

**Acknowledgment**

*[Format shall be based on the latest Rules on Notarial Practice]*

## Omnibus Sworn Statement (Revised)

*[shall be submitted with the Bid]*

REPUBLIC OF THE PHILIPPINES )  
CITY/MUNICIPALITY OF \_\_\_\_\_ ) S.S.

### AFFIDAVIT

I, [Name of Affiant], of legal age, [Civil Status], [Nationality], and residing at [Address of Affiant], after having been duly sworn in accordance with law, do hereby depose and state that:

1. *[Select one, delete the other:]*

*[If a sole proprietorship:]* I am the sole proprietor or authorized representative of [Name of Bidder] with office address at [address of Bidder];

*[If a partnership, corporation, cooperative, or joint venture:]* I am the duly authorized and designated representative of [Name of Bidder] with office address at [address of Bidder];

2. *[Select one, delete the other:]*

*[If a sole proprietorship:]* As the owner and sole proprietor, or authorized representative of [Name of Bidder], I have full power and authority to do, execute and perform any and all acts necessary to participate, submit the bid, and to sign and execute the ensuing contract for [Name of the Project] of the [Name of the Procuring Entity], as shown in the attached duly notarized Special Power of Attorney;

*[If a partnership, corporation, cooperative, or joint venture:]* I am granted full power and authority to do, execute and perform any and all acts necessary to participate, submit the bid, and to sign and execute the ensuing contract for [Name of the Project] of the [Name of the Procuring Entity], as shown in the attached [state title of attached document showing proof of authorization (e.g., duly notarized Secretary's Certificate, Board/Partnership Resolution, or Special Power of Attorney, whichever is applicable)];

3. [Name of Bidder] is not "blacklisted" or barred from bidding by the Government of the Philippines or any of its agencies, offices, corporations, or Local Government Units, foreign government/foreign or international financing institution whose blacklisting rules have been recognized by the Government Procurement Policy Board, **by itself or by relation, membership, association, affiliation, or controlling interest with another blacklisted person or entity as defined and provided for in the Uniform Guidelines on Blacklisting;**

4. Each of the documents submitted in satisfaction of the bidding requirements is an authentic copy of the original, complete, and all statements and information provided therein are true and correct;

5. [Name of Bidder] is authorizing the Head of the Procuring Entity or its duly authorized representative(s) to verify all the documents submitted;

6. *[Select one, delete the rest:]*

*[If a sole proprietorship:]* The owner or sole proprietor is not related to the Head of the Procuring Entity, members of the Bids and Awards Committee (BAC), the Technical Working Group, and the BAC Secretariat, the head of the Project Management Office or



the end-user unit, and the project consultants by consanguinity or affinity up to the third civil degree;

*[If a partnership or cooperative:]* None of the officers and members of *[Name of Bidder]* is related to the Head of the Procuring Entity, members of the Bids and Awards Committee (BAC), the Technical Working Group, and the BAC Secretariat, the head of the Project Management Office or the end-user unit, and the project consultants by consanguinity or affinity up to the third civil degree;

*[If a corporation or joint venture:]* None of the officers, directors, and controlling stockholders of *[Name of Bidder]* is related to the Head of the Procuring Entity, members of the Bids and Awards Committee (BAC), the Technical Working Group, and the BAC Secretariat, the head of the Project Management Office or the end-user unit, and the project consultants by consanguinity or affinity up to the third civil degree;

7. *[Name of Bidder]* complies with existing labor laws and standards; and
8. *[Name of Bidder]* is aware of and has undertaken the responsibilities as a Bidder in compliance with the Philippine Bidding Documents, which includes:
  - a. Carefully examining all of the Bidding Documents;
  - b. Acknowledging all conditions, local or otherwise, affecting the implementation of the Contract;
  - c. Making an estimate of the facilities available and needed for the contract to be bid, if any; and
  - d. Inquiring or securing Supplemental/Bid Bulletin(s) issued for the *[Name of the Project]*.
9. *[Name of Bidder]* did not give or pay directly or indirectly, any commission, amount, fee, or any form of consideration, pecuniary or otherwise, to any person or official, personnel or representative of the government in relation to any procurement project or activity.
10. **In case advance payment was made or given, failure to perform or deliver any of the obligations and undertakings in the contract shall be sufficient grounds to constitute criminal liability for Swindling (Estafa) or the commission of fraud with unfaithfulness or abuse of confidence through misappropriating or converting any payment received by a person or entity under an obligation involving the duty to deliver certain goods or services, to the prejudice of the public and the government of the Philippines pursuant to Article 315 of Act No. 3815 s. 1930, as amended, or the Revised Penal Code.**

IN WITNESS WHEREOF, I have hereunto set my hand this \_\_\_ day of \_\_\_, 20\_\_ at \_\_\_\_\_, Philippines.

*[Insert NAME OF BIDDER OR ITS AUTHORIZED REPRESENTATIVE]*

*[Insert signatory's legal capacity]*  
Affiant

**[Jurat]**

*[Format shall be based on the latest Rules on Notarial Practice]*

## Performance Securing Declaration (Revised)

*[if used as an alternative performance security but it is not required to be submitted with the Bid, as it shall be submitted within ten (10) days after receiving the Notice of Award]*

---

REPUBLIC OF THE PHILIPPINES)  
CITY OF \_\_\_\_\_ ) S.S.

### PERFORMANCE SECURING DECLARATION

Invitation to Bid: [Insert Reference Number indicated in the Bidding Documents] To:  
[Insert name and address of the Procuring Entity]

I/We, the undersigned, declare that:

1. I/We understand that, according to your conditions, to guarantee the faithful performance by the supplier/distributor/manufacturer/contractor/consultant of its obligations under the Contract, I/we shall submit a Performance Securing Declaration within a maximum period of ten (10) calendar days from the receipt of the Notice of Award prior to the signing of the Contract.
2. I/We accept that: I/we will be automatically disqualified from bidding for any procurement contract with any procuring entity for a period of one (1) year for the first offense, or two (2) years **for the second offense**, upon receipt of your Blacklisting Order if I/We have violated my/our obligations under the Contract;
3. I/We understand that this Performance Securing Declaration shall cease to be valid upon:
  - a. issuance by the Procuring Entity of the Certificate of Final Acceptance, subject to the following conditions:
    - i. Procuring Entity has no claims filed against the contract awardee;
    - ii. It has no claims for labor and materials filed against the contractor; and
    - iii. Other terms of the contract; or
  - b. replacement by the winning bidder of the submitted PSD with a performance security in any of the prescribed forms under Section 39.2 of the 2016 revised IRR of RA No. 9184 as required by the end-user.

**IN WITNESS WHEREOF**, I/We have hereunto set my/our hand/s this \_\_\_\_ day of [month]  
[year] at [place of execution].

*[Insert NAME OF BIDDER OR ITS  
AUTHORIZED REPRESENTATIVE]  
[Insert signatory's legal capacity]  
Affiant*

**[Jurat]**

*[Format shall be based on the latest Rules on Notarial Practice]*

LIST OF ALL ON-GOING GOVERNMENT AND PRIVATE CONTRACTS

NAME OF CONTRACTOR: \_\_\_\_\_

PROJECT TITLE (Name of the Contract) & EXACT PROJECT LOCATION	DATE OF CONTRACT	CONTRACT DURATION	PROJECT OWNER & POSTAL ADDRESS	NATURE OF WORK	CONTRACTOR'S ROLE (SOLE CONTRACTOR, SUBCONTRACTOR, PARTNER IN A JV) and PERCENTAGE OF PARTICIPATION	TOTAL CONTRACT VALUE AT AWARD	DATE OF COMPLETION or ESTIMATED COMPLETION TIME	TOTAL CONTRACT VALUE AT COMPLETION IF APPLICABLE	PERCENTAGE		VALUE OF OUTSTANDING WORKS (IN PHP)
									ACTUAL ACCOMPLISHMENT	PLANNED ACCOMPLISHMENT	
									TOTAL AMOUNT (Php) OF OUTSTANDING WORKS		

PHOTOCOPY ADDITIONAL FORMS, IF NECESSARY

**LIST OF ALL AWARDED BUT NOT YET STARTED GOVERNMENT AND PRIVATE CONTRACTS OF THE BIDDER**

**NAME OF CONTRACTOR:** \_\_\_\_\_

**PROJECT TITLE:** \_\_\_\_\_

PROJECT TITLE & EXACT LOCATION	MAJOR SCOPE OF WORKS & DATE STARTED	NAME AND ADDRESS OF PROJECT OWNER	CONTRACT PRICE (PHP) AS AWARDED	DATE OF SCHEDULED COMPLETION	ROLE OF BIDDER IN THE <u>CONTRACT SOLE CONTRACTOR / SUB-CONTRACTOR/PARTNER IN A</u>
	TOTAL AMOUNT OF CONTRACT (Php)				

**SINGLE LARGEST COMPLETED CONTRACT SIMILAR TO THE CONTRACT TO BE BID**

**NAME OF CONTRACTOR:** \_\_\_\_\_

**PROJECT TITLE:** \_\_\_\_\_

PROJECT TITLE (Name of the Contract) & EXACT PROJECT LOCATION	DATE OF CONTRACT	CONTRACT DURATION	PROJECT OWNER & POSTAL ADDRESS	NATURE OF WORK	CONTRACTOR'S ROLE (SOLE CONTRACTOR, SUBCONTRACTOR, PARTNER IN A JV) and PERCENTAGE OF PARTICIPATION	TOTAL CONTRACT VALUE AT AWARD	DATE OF COMPLETION or ESTIMATED COMPLETION TIME	TOTAL CONTRACT VALUE AT COMPLETION IF APPLICABLE

**LIST OF MAJOR EQUIPMENT TO BE USED FOR THE PROJECT**

**NAME OF CONTRACTOR:** \_\_\_\_\_

**PROJECT TITLE:** \_\_\_\_\_

TYPE	DESCRIPTION / CAPACITY	SERIAL NO.	YEAR ACQUIRED	PRESENT LOCATION (SPECIFIC ADDRESS)	STATUS OF AVAILABILITY (OWNED/LEASED)

**A. LIST OF KEY CONSTRUCTION PERSONNEL TO BE ASSIGNED TO THE PROJECT**

**NAME OF CONTRACTOR:** \_\_\_\_\_

**PROJECT TITLE:** \_\_\_\_\_

NAME	POSITION	AGE	EDUCATIONAL ATTAINMENT	TYPE OF CONSTRUCTION EXPERIENCE	NO.OF YEARS WITH THE CONTRACTOR	PROFESSION	PRC NO.

## COMPUTATION OF NET FINANCIAL CONTRACTING CAPACITY (NFCC)

NAME OF BIDDER: \_\_\_\_\_

CURRENT ASSETS*		PHP	_____
(LESS) CURRENT LIABILITIES*	(LESS)	PHP	_____
NETWORTH		PHP	_____
NETWORTH x 15	x 15	PHP	_____
(LESS) VALUE OF ALL OUTSTANDING ON-GOING CONTRACTS**	(LESS)	PHP	_____
(LESS) VALUE OF ALL AWARDED BUT NOT YET STARTED CONTRACTS AS OF DATE**	(LESS)	PHP	_____
<b>NET FINANCIAL CONTRACTING CAPACITY</b>		PHP	_____

NOTES: \* CURRENT ASSETS AND LIABILITIES BASED ON AUDITED FINANCIAL STATEMENT FOR THE PRECEDING CALENDAR YEAR SUBMITTED TO B.I.R.

\*\* BASED ON LIST OF ON-GOING AND AWRDED BUT NOT YEY STARTED CONTRACTS SUBMITTED



REPUBLIC OF THE PHILIPPINES)

\_\_\_\_\_ ) S. S.

**AFFIDAVIT OF UNDERTAKING**

I, \_\_\_\_\_, of legal age, Filipino, \_\_\_\_\_ [OFFICER OR REPRESENTATIVE]

with office address at \_\_\_\_\_ after having been duly sworn to in accordance with law, hereby voluntary depose and state:

That I am duly authorized representative of the [Name of Bidder] to execute this undertaking as evidenced by Secretary's Certificate and Board Resolution.

That [Name of Bidder] bidding for the (Name of Project)

That relative to the aforementioned Project, the [Name of Bidder] hereby undertake that the equipment to be use and the key personnel to be assign shall exclusively be used and will only perform to the said project until its completion.

That I am executing this affidavit to attest to the truth of the foregoing and in compliance with the submission of the technical requirements for the public bidding of the said project.

IN WITNESS HEREOF, I have hereunto signed my name below this \_\_\_\_\_ day of \_\_\_\_\_ at \_\_\_\_\_.

AFFIANT FURTHER SAYETH NAUGHT.

\_\_\_\_\_

Affiant

SUBSCRIBED AND SWORN TO BEFORE ME this \_\_\_ day of \_\_\_\_\_  
\_\_\_\_\_ in \_\_\_\_\_

affiant exhibiting to me his/her \_\_\_\_\_ issued at \_\_\_\_\_ on \_\_\_\_\_.

Doc. No. ;  
Page No. ;  
Book No. ;  
Series of 2020

\_\_\_\_\_

Notary Public

