

PHILIPPINE BIDDING DOCUMENTS

**Procurement of
INFRASTRUCTURE
PROJECTS**

Government of the Republic of the Philippines

**PROPOSED IMPROVEMENT OF TANDANG SORA SHRINE
AT BANLAT ROAD**

**Project number:
22-00053**

**Sixth Edition
July 2020**

Preface

These Philippine Bidding Documents (PBDs) for the procurement of Infrastructure Projects (hereinafter referred to also as the “Works”) through Competitive Bidding have been prepared by the Government of the Philippines for use by all branches, agencies, departments, bureaus, offices, or instrumentalities of the government, including government-owned and/or -controlled corporations, government financial institutions, state universities and colleges, local government units, and autonomous regional government. The procedures and practices presented in this document have been developed through broad experience, and are for mandatory use in projects that are financed in whole or in part by the Government of the Philippines or any foreign government/foreign or international financing institution in accordance with the provisions of the 2016 revised Implementing Rules and Regulations (IRR) of Republic Act (RA) No. 9184.

The PBDs are intended as a model for admeasurements (unit prices or unit rates in a bill of quantities) types of contract, which are the most common in Works contracting.

The Bidding Documents shall clearly and adequately define, among others: (i) the objectives, scope, and expected outputs and/or results of the proposed contract; (ii) the eligibility requirements of Bidders; (iii) the expected contract duration; and (iv) the obligations, duties, and/or functions of the winning Bidder.

Care should be taken to check the relevance of the provisions of the PBDs against the requirements of the specific Works to be procured. If duplication of a subject is inevitable in other sections of the document prepared by the Procuring Entity, care must be exercised to avoid contradictions between clauses dealing with the same matter.

Moreover, each section is prepared with notes intended only as information for the Procuring Entity or the person drafting the Bidding Documents. They shall not be included in the final documents. The following general directions should be observed when using the documents:

- a. All the documents listed in the Table of Contents are normally required for the procurement of Infrastructure Projects. However, they should be adapted as necessary to the circumstances of the particular Project.
- b. Specific details, such as the “*name of the Procuring Entity*” and “*address for bid submission*,” should be furnished in the Instructions to Bidders, Bid Data Sheet, and Special Conditions of Contract. The final documents should contain neither blank spaces nor options.
- c. This Preface and the footnotes or notes in italics included in the Invitation to Bid, BDS, General Conditions of Contract, Special Conditions of Contract, Specifications, Drawings, and Bill of Quantities are not part of the text of the final document, although they contain instructions that the Procuring Entity should strictly follow.
- d. The cover should be modified as required to identify the Bidding Documents as to the names of the Project, Contract, and Procuring Entity, in addition to date of issue.

- e. Modifications for specific Procurement Project details should be provided in the Special Conditions of Contract as amendments to the Conditions of Contract. For easy completion, whenever reference has to be made to specific clauses in the Bid Data Sheet or Special Conditions of Contract, these terms shall be printed in bold typeface on Sections I (Instructions to Bidders) and III (General Conditions of Contract), respectively.
- f. For guidelines on the use of Bidding Forms and the procurement of Foreign-Assisted Projects, these will be covered by a separate issuance of the Government Procurement Policy Board.

TABLE OF CONTENTS

Glossary of Terms, Abbreviations, and Acronyms.....	5
Section I. Invitation to Bid	8
Section II. Instructions to Bidders.....	9
1. Scope of Bid.....	10
2. Funding Information	10
3. Bidding Requirements.....	10
4. Corrupt, Fraudulent, Collusive, Coercive, and Obstructive Practices	10
5. Eligible Bidders.....	11
6. Origin of Associated Goods	11
7. Subcontracts	11
8. Pre-Bid Conference.....	12
9. Clarification and Amendment of Bidding Documents.....	12
10. Documents Comprising the Bid: Eligibility and Technical Components.....	12
11. Documents Comprising the Bid: Financial Component	13
12. Alternative Bids	13
13. Bid Prices	13
14. Bid and Payment Currencies.....	13
15. Bid Security.....	14
16. Sealing and Marking of Bids.....	14
17. Deadline for Submission of Bids	14
18. Opening and Preliminary Examination of Bids	14
19. Detailed Evaluation and Comparison of Bids.....	14
20. Post Qualification.....	15
21. Signing of the Contract	15
Section III. Bid Data Sheet.....	16
Section IV. General Conditions of Contract	19
1. Scope of Contract.....	20
2. Sectional Completion of Works	20
3. Possession of Site.....	20
4. The Contractor’s Obligations.....	20
5. Performance Security	20
6. Site Investigation Reports	21

7.	Warranty.....	21
8.	Liability of the Contractor.....	21
9.	Termination for Other Causes.....	21
10.	Dayworks	21
11.	Program of Work.....	22
12.	Instructions, Inspections and Audits	22
13.	Advance Payment.....	22
14.	Progress Payments	22
15.	Operating and Maintenance Manuals.....	22
	Section V. Special Conditions of Contract.....	24
	Section VI. Specifications	26
	Section VII. Drawings.....	28
	Section VIII. Bill of Quantities	29
	Section IX. Checklist of Technical and Financial Documents.....	31

Glossary of Terms, Abbreviations, and Acronyms

ABC – Approved Budget for the Contract.

ARCC – Allowable Range of Contract Cost.

BAC – Bids and Awards Committee.

Bid – A signed offer or proposal to undertake a contract submitted by a bidder in response to and in consonance with the requirements of the bidding documents. Also referred to as *Proposal* and *Tender*. (2016 revised IRR, Section 5[c])

Bidder – Refers to a contractor, manufacturer, supplier, distributor and/or consultant who submits a bid in response to the requirements of the Bidding Documents. (2016 revised IRR, Section 5[d])

Bidding Documents – The documents issued by the Procuring Entity as the bases for bids, furnishing all information necessary for a prospective bidder to prepare a bid for the Goods, Infrastructure Projects, and/or Consulting Services required by the Procuring Entity. (2016 revised IRR, Section 5[e])

BIR – Bureau of Internal Revenue.

BSP – Bangko Sentral ng Pilipinas.

CDA – Cooperative Development Authority.

Consulting Services – Refer to services for Infrastructure Projects and other types of projects or activities of the GOP requiring adequate external technical and professional expertise that are beyond the capability and/or capacity of the GOP to undertake such as, but not limited to: (i) advisory and review services; (ii) pre-investment or feasibility studies; (iii) design; (iv) construction supervision; (v) management and related services; and (vi) other technical services or special studies. (2016 revised IRR, Section 5[i])

Contract – Refers to the agreement entered into between the Procuring Entity and the Supplier or Manufacturer or Distributor or Service Provider for procurement of Goods and Services; Contractor for Procurement of Infrastructure Projects; or Consultant or Consulting Firm for Procurement of Consulting Services; as the case may be, as recorded in the Contract Form signed by the parties, including all attachments and appendices thereto and all documents incorporated by reference therein.

Contractor – is a natural or juridical entity whose proposal was accepted by the Procuring Entity and to whom the Contract to execute the Work was awarded. Contractor as used in these Bidding Documents may likewise refer to a supplier, distributor, manufacturer, or consultant.

CPI – Consumer Price Index.

DOLE – Department of Labor and Employment.

DTI – Department of Trade and Industry.

Foreign-funded Procurement or Foreign-Assisted Project – Refers to procurement whose funding source is from a foreign government, foreign or international financing institution as specified in the Treaty or International or Executive Agreement. (2016 revised IRR, Section 5[b]).

GFI – Government Financial Institution.

GOCC – Government-owned and/or –controlled corporation.

Goods – Refer to all items, supplies, materials and general support services, except Consulting Services and Infrastructure Projects, which may be needed in the transaction of public businesses or in the pursuit of any government undertaking, project or activity, whether in the nature of equipment, furniture, stationery, materials for construction, or personal property of any kind, including non-personal or contractual services such as the repair and maintenance of equipment and furniture, as well as trucking, hauling, janitorial, security, and related or analogous services, as well as procurement of materials and supplies provided by the Procuring Entity for such services. The term “related” or “analogous services” shall include, but is not limited to, lease or purchase of office space, media advertisements, health maintenance services, and other services essential to the operation of the Procuring Entity. (2016 revised IRR, Section 5[r])

GOP – Government of the Philippines.

Infrastructure Projects – Include the construction, improvement, rehabilitation, demolition, repair, restoration or maintenance of roads and bridges, railways, airports, seaports, communication facilities, civil works components of information technology projects, irrigation, flood control and drainage, water supply, sanitation, sewerage and solid waste management systems, shore protection, energy/power and electrification facilities, national buildings, school buildings, hospital buildings, and other related construction projects of the government. Also referred to as *civil works or works*. (2016 revised IRR, Section 5[u])

LGUs – Local Government Units.

NFCC – Net Financial Contracting Capacity.

NGA – National Government Agency.

PCAB – Philippine Contractors Accreditation Board.

PhilGEPS - Philippine Government Electronic Procurement System.

Procurement Project – refers to a specific or identified procurement covering goods, infrastructure project or consulting services. A Procurement Project shall be described, detailed, and scheduled in the Project Procurement Management Plan prepared by the agency which shall be consolidated in the procuring entity's Annual Procurement Plan. (GPPB Circular No. 06-2019 dated 17 July 2019)

PSA – Philippine Statistics Authority.

SEC – Securities and Exchange Commission.

SLCC – Single Largest Completed Contract.

UN – United Nations.

Section I. Invitation to Bid

Notes on the Invitation to Bid

The Invitation to Bid (IB) provides information that enables potential Bidders to decide whether to participate in the procurement at hand. The IB shall be posted in accordance with Section 21.2 of the 2016 revised IRR of RA No. 9184.

Apart from the essential items listed in the Bidding Documents, the IB should also indicate the following:

- a. The date of availability of the Bidding Documents, which shall be from the time the IB is first advertised/posted until the deadline for the submission and receipt of bids;
- b. The place where the Bidding Documents may be acquired or the website where it may be downloaded;
- c. The deadline for the submission and receipt of bids; and
- d. Any important bid evaluation criteria.

The IB should be incorporated into the Bidding Documents. The information contained in the IB must conform to the Bidding Documents and in particular to the relevant information in the Bid Data Sheet.



REPUBLIC OF THE PHILIPPINES
QUEZON CITY GOVERNMENT
BIDS AND AWARDS COMMITTEE FOR INFRASTRUCTURE &
CONSULTANCY



2nd floor, Finance Building, Procurement Department, Quezon City Hall Complex, Elliptical Road, Quezon City

February 17, 2022

Invitation to Bid

No	Project No.	Project Name	Location	Amount	Durat on Cal. Days	Office	Source Fund
<u>Buildings – Small B</u>							
1	22-0002B	Proposed Construction of Hand Washing Facility and Rehabilitation of Day Care Center at District 5 / Area VIII (Cluster 3)	Kailigayahan, Fairview	4,390,415.05	60	Engineering Department	Engineering Department-Continuing Appropriation
2	22-00036	Proposed Rehabilitation of Comfort Rooms (DepEd Building B) at Goodwill Elementary School	Bagbag	1,502,623.78	60	Engineering Department	Special Education Fund
3	22-00037	Proposed Construction of Perimeter Fence and Rehabilitation of Gates and Guard House at Bistekville 1 at Barangay Payatas	Payatas	1,990,571.27	90	Engineering Department	Engineering Department-Continuing Appropriation
4	22-00038	Proposed Rehabilitation of 6th Floor and Upper Deck Ceiling and Waterproofing of Roof deck at Civic Building F at Quezon City Hall Compound	Central	5,864,452.20	90	Engineering Department	Engineering Department
5	22-00039	Proposed Construction of Waiting Sheds for Various Quezon City Bus Stops (Quezon City Hall Bus Augmentation Program)	Various Barangays	7,125,752.82	180	Engineering Department	Engineering Department-Continuing Appropriation
6	22-00040	Proposed Construction of Three (3) storey Multi-Purpose Building at Barangay Manresa	Manresa	9,702,527.91	180	Engineering Department	Engineering Department
7	22-00041	Proposed Renovation of Office of the City Mayor, Third Floor Main Building, QC Hall Compound at Barangay Central	Central	13,510,259.60	180	Engineering Department	Engineering Department
8	22-00042	Proposed Construction of Three (3) storey Multi-Purpose Building at Barangay Vasra	Vasra	17,261,582.72	210	Engineering Department	OCM-20% CDF
9	22-00043	Proposed Construction of Three (3) storey with Roof Deck Multi-Purpose Building at Barangay Bagumbayan	Bagumbayan	23,868,555.52	270	Engineering Department	OCM-20% CDF
10	22-00044	Proposed Construction of Multi-Purpose Building (at Madjaas Street) at Barangay Payatas B (Phase 2)	Payatas	27,173,801.07	210	Engineering Department	OCM-20% CDF

Buildings – Medium A

11	22-00045	Proposed Construction of Four (4) storey with Deck Quezon City Schools Division Office Multi-Purpose Building at Barangay Sto. Cristo	Sto. Cristo	50,395,670.16	330	Engineering Department	OCM-20% CDF
12	22-00046	Proposed Construction of Four (4) storey with Roof Deck Barangay Hall at Barangay Greater Lagro	Greater Lagro	59,282,536.60	360	Engineering Department	Engineering Department
13	22-00047	Proposed Construction of four (4) storey Multi-Purpose Building (Evacuation Center, Offices and Volleyball Court) at Barangay Sta. Lucia	Sta. Lucia	76,318,551.21	330	Engineering Department	OCM-20% CDF
14	22-00048	Proposed Construction of Housing No. 17 (Wright Park) Phase 1	Bagong Silangan	106,575,757.08	360	Engineering Department	Housing Community Development Resettlement Dept.

Flood Control – Small B

15	22-00049	Proposed Construction of Reinforced Concrete Canal at Sampaguita Creek (Sitio Pugot) in Barangay Payatas	Payatas	26,207,918.10	210	Engineering Department	OCM-20% CDF
16	22-00050	Proposed Construction of Reinforced Concrete Canal at Creek (Pocalari Compound)	Bagong Silangan	47,192,576.14	270	Engineering Department	OCM-20% CDF

Parks – Small B

17	22-00051	Proposed Improvement of Blue Ridge B Park at Comets Loop Street	Blue Ridge B	6,221,182.85	135	Parks Development & Admin. Dept.	Engineering Department
18	22-00052	Proposed Improvement of North Olympus Park at Bethel Street, North Olympus Subdivision	Kaligayahan	7,232,959.22	135	Parks Development & Admin. Dept.	Engineering Department
19	22-00053	Proposed Improvement of Tandang Sora Shrine at Banlat Road	Tandang Sora	23,499,139.15	300	Parks Development & Admin. Dept.	Engineering Department

Roads – Small B

20	22-00054	Proposed Rehabilitation of Drainage at Children's Museum and Library, Inc. (CMLI) and Nego-Eskwela Compound in Barangay Project 6	Project 6	2,424,449.10	90	Engineering Dept.	OCM-20% CDF
21	22-00055	Proposed Rehabilitation (Surface Improvement) of Champaca Street	Sauyo	3,337,874.58	30	Engineering Dept.	OCM-20% CDF

22	22-00056	Proposed Rehabilitation of Road and Drainage at Namappa Block 3 HOA	Batasan Hills	3,721,205.18	90	Engineering Dept.	OCM-20% CDF
----	----------	---	---------------	--------------	----	-------------------	-------------

1. The **QUEZON CITY LOCAL GOVERNMENT**, through *funding source of various years* intends to apply the sum stated above being the Approved Budget for the Contract (ABC) to payments under the contract *for the above stated Projects*. Bids received in excess of the ABC shall be automatically rejected at bid opening.
2. The **QUEZON CITY LOCAL GOVERNMENT** now invites bids for the above Procurement Project. Completion of the Works is required *as stated above*. Bidders should have completed a contract similar to the Project. The description of an eligible bidder is contained in the Bidding Documents, particularly, in Section II (Instructions to Bidders).
3. Bidding will be conducted through open competitive bidding procedures using non-discretionary *“pass/fail”* criterion as specified in the 2016 revised Implementing Rules and Regulations (IRR) of Republic Act (RA) No. 9184.
4. Interested bidders may obtain further information from **QUEZON CITY LOCAL GOVERNMENT – BAC Secretariat** and inspect the Bidding Documents at the address given below *weekdays from 8:00 am. – 5:00 p.m.*
5. A complete set of Bidding Documents may be acquired by interested bidders on **18 February 2022 (Friday)** from given address and website/s below *and upon payment of a non-refundable fee for the Bidding Documents, pursuant to the latest Guidelines issued by the GPPB*. The Procuring Entity shall allow the bidder to present its proof of payment for the fees *presented in person*.

STANDARD RATES:

Approved Budget for the Contract	Maximum Cost of Bidding Documents (in Philippine Peso)
More than 1 Million up to 5 Million	5,000.00
More than 5 Million up to 10 Million	10,000.00
More than 10 Million up to 50 Million	25,000.00
More than 50 Million up to 500 Million	50,000.00
More than 500 Million	75,000.00

The following are the requirements for purchase of Bidding Documents;

1. PhilGEPS Registration Certificate (Platinum – 3 Pages)
2. Document Request List (DRL)
3. Authorization to purchase bidding documents
 - 3.1 Secretary’s Certificate (for corporation)
 - 3.2 Special Power of Attorney (for sole proprietorship)
4. Notarized Joint Venture Agreement (if applicable)
5. Letter of Intent

It must be duly received by the BAC Secretariat at 2nd Floor, Procurement Department, Finance Building, Quezon City Hall Compound on or before **February 28, 2022 - 5:00PM**.

6. The **QC- BAC- INFRASTRUCTURE & CONSULTANCY** will hold a Pre-Bid Conference¹ on **February 28, 2022 at 10:00 AM at 2nd Floor, Procurement Department-Bidding Room, Finance Building, Quezon City Hall Compound** or we encourage the prospective bidders to join through our **Virtual Conference (ZOOM APP)** which shall be open to prospective bidders.

¹ May be deleted in case the ABC is less than One Million Pesos (PhP1,000,000) where the Procuring Entity may not hold a pre-bid conference.

Virtual Conference (ZOOM APP)

Meeting ID: 854 9489 0133

Password: 273320

7. Bids must be duly received by the BAC Secretariat through manual submission at the office address as indicated below, on or before **March 16, 2022 – 9:00AM**. Late bids shall not be accepted.
8. All bids must be accompanied by a bid security in any of the acceptable forms and in the amount stated in **ITB Clause 16**.
9. Bid opening shall be on **March 16, 2022 - 10:00 AM** at **2nd Floor, Procurement Department-Bidding Room, Finance Building, Quezon City Hall Compound** and/or via Zoom. Bids will be opened in the presence of the bidders' representatives who choose to attend the activity.

Virtual Conference (ZOOM APP)

Meeting ID: 810 3646 5257

Password: 201522

10. The *Quezon City Local Government* reserves the right to reject any and all bids, declare a failure of bidding, or not award the contract at any time prior to contract award in accordance with Sections 35.6 and 41 of the 2016 revised Implementing Rules and Regulations (IRR) of RA No. 9184, without thereby incurring any liability to the affected bidder or bidders.
11. For further information, please refer to:

ATTY. DOMINIC B. GARCIA

OIC, Procurement Department

2nd Floor, Procurement Department,

Finance Building, Quezon City Hall Compound

Elliptical Road, Barangay Central Diliman, Quezon City.

Tel. No. (02)8988-4242 loc. 8506/8710

Email Add: bacinfra.procurement@quezoncity.gov.ph

Website: www.quezoncity.gov.ph

12. You may visit the following websites:

For downloading of Bidding Documents: <https://quezoncity.gov.ph/public-notices/procurement/>

By:

ATTY. MARK DALE DIAMOND P. PERRAL

Chairman, BAC-Infra and Consultancy 

Section II. Instructions to Bidders

Notes on the Instructions to Bidders

This Section on the Instruction to Bidders (ITB) provides the information necessary for bidders to prepare responsive bids, in accordance with the requirements of the Procuring Entity. It also provides information on bid submission, eligibility check, opening and evaluation of bids, post-qualification, and on the award of contract.

1. **Scope of Bid**

The Procuring Entity, **Quezon City Government** invites Bids for the **PROPOSED IMPROVEMENT OF TANDANG SORA SHRINE AT BANLAT ROAD**, with Project Identification Number **22-00053**.

[Note: The Project Identification Number is assigned by the Procuring Entity based on its own coding scheme and is not the same as the PhilGEPS reference number, which is generated after the posting of the bid opportunity on the PhilGEPS website.]

The Procurement Project (referred to herein as “Project”) is for the construction of Works, as described in Section VI (Specifications).

2. **Funding Information**

2.1. The GOP through the source of funding as indicated below for **2022** in the amount of **Twenty-Three Million Four Hundred Ninety-Nine Thousand One Hundred Thirty-Nine Pesos and 15/100 Cts. (P 23,499,139.15)**.

2.2. The source of funding is:

a. LGUs, the Annual or Supplemental Budget, as approved by the Sanggunian.

3. **Bidding Requirements**

The Bidding for the Project shall be governed by all the provisions of RA No. 9184 and its 2016 revised IRR, including its Generic Procurement Manual and associated policies, rules and regulations as the primary source thereof, while the herein clauses shall serve as the secondary source thereof.

Any amendments made to the IRR and other GPPB issuances shall be applicable only to the ongoing posting, advertisement, or invitation to bid by the BAC through the issuance of a supplemental or bid bulletin.

The Bidder, by the act of submitting its Bid, shall be deemed to have inspected the site, determined the general characteristics of the contracted Works and the conditions for this Project, such as the location and the nature of the work; (b) climatic conditions; (c) transportation facilities; (c) nature and condition of the terrain, geological conditions at the site communication facilities, requirements, location and availability of construction aggregates and other materials, labor, water, electric power and access roads; and (d) other factors that may affect the cost, duration and execution or implementation of the contract, project, or work and examine all instructions, forms, terms, and project requirements in the Bidding Documents.

4. **Corrupt, Fraudulent, Collusive, Coercive, and Obstructive Practices**

The Procuring Entity, as well as the Bidders and Contractors, shall observe the highest standard of ethics during the procurement and execution of the contract. They or through an agent shall not engage in corrupt, fraudulent, collusive, coercive, and

obstructive practices defined under Annex “P” of the 2016 revised IRR of RA No. 9184 or other integrity violations in competing for the Project.

5. Eligible Bidders

- 5.1. Only Bids of Bidders found to be legally, technically, and financially capable will be evaluated.
- 5.2. The Bidder must have an experience of having completed a Single Largest Completed Contract (SLCC) that is similar to this Project, equivalent to at least fifty percent (50%) of the ABC adjusted, if necessary, by the Bidder to current prices using the PSA’s CPI, except under conditions provided for in Section 23.4.2.4 of the 2016 revised IRR of RA No. 9184.

A contract is considered to be “similar” to the contract to be bid if it has the major categories of work stated in the **BDS**.
- 5.3. For Foreign-funded Procurement, the Procuring Entity and the foreign government/foreign or international financing institution may agree on another track record requirement, as specified in the Bidding Document prepared for this purpose.
- 5.4. The Bidders shall comply with the eligibility criteria under Section 23.4.2 of the 2016 IRR of RA No. 9184.

6. Origin of Associated Goods

There is no restriction on the origin of Goods other than those prohibited by a decision of the UN Security Council taken under Chapter VII of the Charter of the UN.

7. Subcontracts

- 7.1. The Bidder may subcontract portions of the Project to the extent allowed by the Procuring Entity as stated herein, but in no case more than fifty percent (50%) of the Project.

The Procuring Entity has prescribed that:

- a. **Subcontracting is not allowed.**

- 7.1. *[If Procuring Entity has determined that subcontracting is allowed during the bidding , state:]* The Bidder must submit together with its Bid the documentary requirements of the subcontractor(s) complying with the eligibility criterial stated in **ITB** Clause 5 in accordance with Section 23.4 of the 2016 revised IRR of RA No. 9184 pursuant to Section 23.1 thereof.
- 7.2. *[If subcontracting is allowed during the contract implementation stage, state:]* The Supplier may identify its subcontractor during the contract implementation stage. Subcontractors identified during the bidding may be changed during the implementation of this Contract. Subcontractors must submit the documentary

requirements under Section 23.1 of the 2016 revised IRR of RA No. 9184 and comply with the eligibility criteria specified in **ITB** Clause 5 to the implementing or end-user unit.

- 7.3. Subcontracting of any portion of the Project does not relieve the Contractor of any liability or obligation under the Contract. The Supplier will be responsible for the acts, defaults, and negligence of any subcontractor, its agents, servants, or workmen as fully as if these were the Contractor's own acts, defaults, or negligence, or those of its agents, servants, or workmen.

8. Pre-Bid Conference

The Procuring Entity will hold a pre-bid conference for this Project on the specified date and time and either at its physical address on **February 28, 2022, 10:00 A.M. at 2nd Floor, Procurement Department-Bidding Room, Finance Building, Quezon City Hall Compound** and/or we encourage the prospective bidders to join through our **Virtual Conference (ZOOM APP) Meeting ID: 854 9489 0133 Password: 273320**

9. Clarification and Amendment of Bidding Documents

Prospective bidders may request for clarification on and/or interpretation of any part of the Bidding Documents. Such requests must be in writing and received by the Procuring Entity, either at its given address or through electronic mail indicated in the **IB**, at least ten (10) calendar days before the deadline set for the submission and receipt of Bids.

10. Documents Comprising the Bid: Eligibility and Technical Components

- 10.1. The first envelope shall contain the eligibility and technical documents of the Bid as specified in **Section IX. Checklist of Technical and Financial Documents**.
- 10.2. If the eligibility requirements or statements, the bids, and all other documents for submission to the BAC are in foreign language other than English, it must be accompanied by a translation in English, which shall be authenticated by the appropriate Philippine foreign service establishment, post, or the equivalent office having jurisdiction over the foreign bidder's affairs in the Philippines. For Contracting Parties to the Apostille Convention, only the translated documents shall be authenticated through an apostille pursuant to GPPB Resolution No. 13-2019 dated 23 May 2019. The English translation shall govern, for purposes of interpretation of the bid.
- 10.3. A valid PCAB License is required, and in case of joint ventures, a valid special PCAB License, and registration for the type and cost of the contract for this Project. Any additional type of Contractor license or permit shall be indicated in the **BDS**.
- 10.4. A List of Contractor's key personnel (e.g., Project Manager, Project Engineers, Materials Engineers, and Foremen) assigned to the contract to be bid, with their

complete qualification and experience data shall be provided. These key personnel must meet the required minimum years of experience set in the **BDS**.

- 10.5. A List of Contractor's major equipment units, which are owned, leased, and/or under purchase agreements, supported by proof of ownership, certification of availability of equipment from the equipment lessor/vendor for the duration of the project, as the case may be, must meet the minimum requirements for the contract set in the **BDS**.

11. Documents Comprising the Bid: Financial Component

- 11.1. The second bid envelope shall contain the financial documents for the Bid as specified in **Section IX. Checklist of Technical and Financial Documents**.
- 11.2. Any bid exceeding the ABC indicated in paragraph 1 of the **IB** shall not be accepted.
- 11.3. For Foreign-funded procurement, a ceiling may be applied to bid prices provided the conditions are met under Section 31.2 of the 2016 revised IRR of RA No. 9184.

12. Alternative Bids

Bidders shall submit offers that comply with the requirements of the Bidding Documents, including the basic technical design as indicated in the drawings and specifications. Unless there is a value engineering clause in the **BDS**, alternative Bids shall not be accepted.

13. Bid Prices

All bid prices for the given scope of work in the Project as awarded shall be considered as fixed prices, and therefore not subject to price escalation during contract implementation, except under extraordinary circumstances as determined by the NEDA and approved by the GPPB pursuant to the revised Guidelines for Contract Price Escalation guidelines.

14. Bid and Payment Currencies

- 14.1. Bid prices may be quoted in the local currency or tradeable currency accepted by the BSP at the discretion of the Bidder. However, for purposes of bid evaluation, Bids denominated in foreign currencies shall be converted to Philippine currency based on the exchange rate as published in the BSP reference rate bulletin on the day of the bid opening.
- 14.2. *Payment of the contract price shall be made in:*
 - a. Philippine Pesos.

15. Bid Security

- 15.1. The Bidder shall submit a Bid Securing Declaration or any form of Bid Security in the amount indicated in the **BDS**, which shall be not less than the percentage of the ABC in accordance with the schedule in the **BDS**.
- 15.2. The Bid and bid security **in no case shall exceed One Hundred Twenty (120) calendar days from the date of opening of bids, unless duly extended by the bidder upon the request of the Head of the Procuring Entity (HoPE) of the Quezon City Local Government**. Any bid not accompanied by an acceptable bid security shall be rejected by the Procuring Entity as non-responsive.

16. Sealing and Marking of Bids

Each Bidder shall submit one copy of the first and second components of its Bid.

The Procuring Entity may request additional hard copies and/or electronic copies of the Bid. However, failure of the Bidders to comply with the said request shall not be a ground for disqualification.

If the Procuring Entity allows the submission of bids through online submission to the given website or any other electronic means, the Bidder shall submit an electronic copy of its Bid, which must be digitally signed. An electronic copy that cannot be opened or is corrupted shall be considered non-responsive and, thus, automatically disqualified.

17. Deadline for Submission of Bids

The Bidders shall submit on the specified date and time and either at its physical address or through online submission as indicated in paragraph 5 of the **IB**.

18. Opening and Preliminary Examination of Bids

- 18.1. The BAC shall open the Bids in public at the time, on the date, and at the place specified in paragraph 9 of the **IB**. The Bidders' representatives who are present shall sign a register evidencing their attendance. In case videoconferencing, webcasting or other similar technologies will be used, attendance of participants shall likewise be recorded by the BAC Secretariat.

In case the Bids cannot be opened as scheduled due to justifiable reasons, the rescheduling requirements under Section 29 of the 2016 revised IRR of RA No. 9184 shall prevail.

- 18.2. The preliminary examination of Bids shall be governed by Section 30 of the 2016 revised IRR of RA No. 9184.

19. Detailed Evaluation and Comparison of Bids

- 19.1. The Procuring Entity's BAC shall immediately conduct a detailed evaluation of all Bids rated "*passed*" using non-discretionary pass/fail criteria. The BAC

shall consider the conditions in the evaluation of Bids under Section 32.2 of 2016 revised IRR of RA No. 9184.

- 19.2. If the Project allows partial bids, all Bids and combinations of Bids as indicated in the **BDS** shall be received by the same deadline and opened and evaluated simultaneously so as to determine the Bid or combination of Bids offering the lowest calculated cost to the Procuring Entity. Bid Security as required by **ITB** Clause 15 shall be submitted for each contract (lot) separately.
- 19.3. In all cases, the NFCC computation pursuant to Section 23.4.2.6 of the 2016 revised IRR of RA No. 9184 must be sufficient for the total of the ABCs for all the lots participated in by the prospective Bidder.

20. Post Qualification

Within a non-extendible period of five (5) calendar days from receipt by the Bidder of the notice from the BAC that it submitted the Lowest Calculated Bid, the Bidder shall submit its latest income and business tax returns filed and paid through the BIR Electronic Filing and Payment System (eFPS), and other appropriate licenses and permits required by law and stated in the **BDS**.

21. Signing of the Contract

The documents required in Section 37.2 of the 2016 revised IRR of RA No. 9184 shall form part of the Contract. Additional Contract documents are indicated in the **BDS**.

Section III. Bid Data Sheet

Notes on the Bid Data Sheet (BDS)

The Bid Data Sheet (BDS) consists of provisions that supplement, amend, or specify in detail, information, or requirements included in the ITB found in Section II, which are specific to each procurement.

This Section is intended to assist the Procuring Entity in providing the specific information in relation to corresponding clauses in the ITB and has to be prepared for each specific procurement.

The Procuring Entity should specify in the BDS information and requirements specific to the circumstances of the Procuring Entity, the processing of the procurement, and the bid evaluation criteria that will apply to the Bids. In preparing the BDS, the following aspects should be checked:

- a. Information that specifies and complements provisions of the ITB must be incorporated.
- b. Amendments and/or supplements, if any, to provisions of the ITB as necessitated by the circumstances of the specific procurement, must also be incorporated.

Bid Data Sheet

ITB Clause																																	
5.2	For this purpose, similar contracts shall refer to contracts which have the same major categories of work.																																
7.1	Subcontracting is not allowed.																																
10.3	<p><i>No additional contractor license or permit is required</i></p> <p><i>In addition, eligible bidders shall qualify or comply with the following:</i></p> <p>1. Bidders with valid Philippine Contractors Accreditation Board (PCAB)</p> <p style="padding-left: 40px;">Type</p> <p style="text-align: center;">Parks - Small B</p>																																
10.4	<p>The minimum work experience requirements for key personnel are the following:</p> <table border="1" style="width: 100%; border-collapse: collapse; margin-top: 5px;"> <thead> <tr> <th style="text-align: center;">Qty.</th> <th style="text-align: center;">Key Personnel</th> <th style="text-align: center;">General Experience</th> <th style="text-align: center;">Relevant Experience</th> </tr> </thead> <tbody> <tr> <td style="text-align: center;">1</td> <td>Project Engineer</td> <td style="text-align: center;">3 years</td> <td style="text-align: center;">3 years</td> </tr> <tr> <td style="text-align: center;">1</td> <td>DPWH duly accredited Materials Engineer</td> <td style="text-align: center;">3 years</td> <td style="text-align: center;">3 years</td> </tr> <tr> <td style="text-align: center;">1</td> <td>Electrical Engineer</td> <td style="text-align: center;">3 years</td> <td style="text-align: center;">3 years</td> </tr> <tr> <td style="text-align: center;">1</td> <td>Safety Officer</td> <td style="text-align: center;">3 years</td> <td style="text-align: center;">3 years</td> </tr> <tr> <td style="text-align: center;">2</td> <td>Construction Foreman</td> <td style="text-align: center;">3 years</td> <td style="text-align: center;">3 years</td> </tr> <tr> <td style="text-align: center;">20</td> <td>Skilled Laborers</td> <td style="text-align: center;">3 years</td> <td style="text-align: center;">3 years</td> </tr> <tr> <td style="text-align: center;">24</td> <td>Unskilled Laborers</td> <td style="text-align: center;">1 year</td> <td style="text-align: center;">3 months</td> </tr> </tbody> </table> <p><i>In addition, the bidder must execute an affidavit of undertaking duly notarized stating that the foregoing personnel shall perform work exclusively for the project until its completion. Please see attached bid forms.</i></p>	Qty.	Key Personnel	General Experience	Relevant Experience	1	Project Engineer	3 years	3 years	1	DPWH duly accredited Materials Engineer	3 years	3 years	1	Electrical Engineer	3 years	3 years	1	Safety Officer	3 years	3 years	2	Construction Foreman	3 years	3 years	20	Skilled Laborers	3 years	3 years	24	Unskilled Laborers	1 year	3 months
Qty.	Key Personnel	General Experience	Relevant Experience																														
1	Project Engineer	3 years	3 years																														
1	DPWH duly accredited Materials Engineer	3 years	3 years																														
1	Electrical Engineer	3 years	3 years																														
1	Safety Officer	3 years	3 years																														
2	Construction Foreman	3 years	3 years																														
20	Skilled Laborers	3 years	3 years																														
24	Unskilled Laborers	1 year	3 months																														
10.5	<p>The minimum major equipment requirements are the following:</p> <table border="1" style="width: 100%; border-collapse: collapse; margin-top: 5px;"> <thead> <tr> <th style="text-align: left;">Equipment</th> <th style="text-align: center;">Capacity</th> <th style="text-align: center;">Number of Units</th> </tr> </thead> <tbody> <tr> <td>Backhoe</td> <td></td> <td style="text-align: center;">1</td> </tr> <tr> <td>Concrete Breaker</td> <td></td> <td style="text-align: center;">1</td> </tr> <tr> <td>Mini Dump Truck</td> <td></td> <td style="text-align: center;">1</td> </tr> <tr> <td>Dump Truck</td> <td></td> <td style="text-align: center;">1</td> </tr> <tr> <td>Concrete Mixer</td> <td></td> <td style="text-align: center;">2</td> </tr> <tr> <td>Concrete Vibrator</td> <td></td> <td style="text-align: center;">2</td> </tr> </tbody> </table>	Equipment	Capacity	Number of Units	Backhoe		1	Concrete Breaker		1	Mini Dump Truck		1	Dump Truck		1	Concrete Mixer		2	Concrete Vibrator		2											
Equipment	Capacity	Number of Units																															
Backhoe		1																															
Concrete Breaker		1																															
Mini Dump Truck		1																															
Dump Truck		1																															
Concrete Mixer		2																															
Concrete Vibrator		2																															

	Generator 1 Welding Machine 2 Minor Tools 4 sets <i>In addition, the bidder must execute an affidavit of undertaking duly notarized stating that the foregoing equipment shall be used exclusively for the project until its completion. Please see attached bid forms.</i>
12	<i>[Insert Value Engineering clause if allowed.]</i>
15.1	The bid security shall be in the form of a Bid Securing Declaration with project number, or any of the following forms and amounts: a) The amount of not less than Php 469,982.78 or equivalent to two percent (2%) of ABC if bid security is in cash, cashier's/manager's check, bank draft/guarantee or irrevocable letter of credit; or b) The amount of not less than Php 1,174,956.96 or equivalent to five percent (5%) of ABC if bid security is in Surety Bond.
19.2	Partial bid is not allowed. The infrastructure project is packaged in a single lot and the lot shall not be divided into sub-lots for the purpose of bidding, evaluation, and contract award.
20	No additional requirement.
21	Additional Contract Documents relevant to the Project as required: 1. Construction Schedule and S-curve, 2. Manpower Schedule, 3. Construction Methods, 4. Equipment Utilization Schedule, 5. PERT/CPM or other acceptable tools of project scheduling, shall be included in the submission of Technical Proposal.

Section IV. General Conditions of Contract

Notes on the General Conditions of Contract

The General Conditions of Contract (GCC) in this Section, read in conjunction with the Special Conditions of Contract in Section V and other documents listed therein, should be a complete document expressing all the rights and obligations of the parties.

Matters governing performance of the Contractor, payments under the contract, or matters affecting the risks, rights, and obligations of the parties under the contract are included in the GCC and Special Conditions of Contract.

Any complementary information, which may be needed, shall be introduced only through the Special Conditions of Contract.

1. **Scope of Contract**

This Contract shall include all such items, although not specifically mentioned, that can be reasonably inferred as being required for its completion as if such items were expressly mentioned herein. All the provisions of RA No. 9184 and its 2016 revised IRR, including the Generic Procurement Manual, and associated issuances, constitute the primary source for the terms and conditions of the Contract, and thus, applicable in contract implementation. Herein clauses shall serve as the secondary source for the terms and conditions of the Contract.

This is without prejudice to Sections 74.1 and 74.2 of the 2016 revised IRR of RA No. 9184 allowing the GPPB to amend the IRR, which shall be applied to all procurement activities, the advertisement, posting, or invitation of which were issued after the effectivity of the said amendment.

2. **Sectional Completion of Works**

If sectional completion is specified in the **Special Conditions of Contract (SCC)**, references in the Conditions of Contract to the Works, the Completion Date, and the Intended Completion Date shall apply to any Section of the Works (other than references to the Completion Date and Intended Completion Date for the whole of the Works).

3. **Possession of Site**

3.1 The Procuring Entity shall give possession of all or parts of the Site to the Contractor based on the schedule of delivery indicated in the **SCC**, which corresponds to the execution of the Works. If the Contractor suffers delay or incurs cost from failure on the part of the Procuring Entity to give possession in accordance with the terms of this clause, the Procuring Entity's Representative shall give the Contractor a Contract Time Extension and certify such sum as fair to cover the cost incurred, which sum shall be paid by Procuring Entity.

3.2 If possession of a portion is not given by the above date, the Procuring Entity will be deemed to have delayed the start of the relevant activities. The resulting adjustments in contract time to address such delay may be addressed through contract extension provided under Annex "E" of the 2016 revised IRR of RA No. 9184.

4. **The Contractor's Obligations**

The Contractor shall employ the key personnel named in the Schedule of Key Personnel indicating their designation, in accordance with **ITB** Clause 10.3 and specified in the **BDS**, to carry out the supervision of the Works.

The Procuring Entity will approve any proposed replacement of key personnel only if their relevant qualifications and abilities are equal to or better than those of the personnel listed in the Schedule.

5. **Performance Security**

- 5.1. Within ten (10) calendar days from receipt of the Notice of Award from the Procuring Entity but in no case later than the signing of the contract by both parties, the successful Bidder shall furnish the performance security in any of the forms prescribed in Section 39 of the 2016 revised IRR.
- 5.2. The Contractor, by entering into the Contract with the Procuring Entity, acknowledges the right of the Procuring Entity to institute action pursuant to RA No. 3688 against any subcontractor be they an individual, firm, partnership, corporation, or association supplying the Contractor with labor, materials and/or equipment for the performance of this Contract.

6. Site Investigation Reports

The Contractor, in preparing the Bid, shall rely on any Site Investigation Reports referred to in the SCC supplemented by any information obtained by the Contractor.

7. Warranty

- 7.1. In case the Contractor fails to undertake the repair works under Section 62.2.2 of the 2016 revised IRR, the Procuring Entity shall forfeit its performance security, subject its property(ies) to attachment or garnishment proceedings, and perpetually disqualify it from participating in any public bidding. All payables of the GOP in his favor shall be offset to recover the costs.
- 7.2. The warranty against Structural Defects/Failures, except that occasioned-on force majeure, shall cover the period from the date of issuance of the Certificate of Final Acceptance by the Procuring Entity. Specific duration of the warranty is found in the SCC.

8. Liability of the Contractor

Subject to additional provisions, if any, set forth in the SCC, the Contractor's liability under this Contract shall be as provided by the laws of the Republic of the Philippines.

If the Contractor is a joint venture, all partners to the joint venture shall be jointly and severally liable to the Procuring Entity.

9. Termination for Other Causes

Contract termination shall be initiated in case it is determined *prima facie* by the Procuring Entity that the Contractor has engaged, before, or during the implementation of the contract, in unlawful deeds and behaviors relative to contract acquisition and implementation, such as, but not limited to corrupt, fraudulent, collusive, coercive, and obstructive practices as stated in ITB Clause 4.

10. Dayworks

Subject to the guidelines on Variation Order in Annex “E” of the 2016 revised IRR of RA No. 9184, and if applicable as indicated in the **SCC**, the Dayworks rates in the Contractor’s Bid shall be used for small additional amounts of work only when the Procuring Entity’s Representative has given written instructions in advance for additional work to be paid for in that way.

11. Program of Work

11.1. The Contractor shall submit to the Procuring Entity’s Representative for approval the said Program of Work showing the general methods, arrangements, order, and timing for all the activities in the Works. The submissions of the Program of Work are indicated in the **SCC**.

11.2. The Contractor shall submit to the Procuring Entity’s Representative for approval an updated Program of Work at intervals no longer than the period stated in the **SCC**. If the Contractor does not submit an updated Program of Work within this period, the Procuring Entity’s Representative may withhold the amount stated in the **SCC** from the next payment certificate and continue to withhold this amount until the next payment after the date on which the overdue Program of Work has been submitted.

12. Instructions, Inspections and Audits

The Contractor shall permit the GOP or the Procuring Entity to inspect the Contractor’s accounts and records relating to the performance of the Contractor and to have them audited by auditors of the GOP or the Procuring Entity, as may be required.

13. Advance Payment

The Procuring Entity shall, upon a written request of the Contractor which shall be submitted as a Contract document, make an advance payment to the Contractor in an amount not exceeding fifteen percent (15%) of the total contract price, to be made in lump sum, or at the most two installments according to a schedule specified in the **SCC**, subject to the requirements in Annex “E” of the 2016 revised IRR of RA No. 9184.

14. Progress Payments

The Contractor may submit a request for payment for Work accomplished. Such requests for payment shall be verified and certified by the Procuring Entity’s Representative/Project Engineer. Except as otherwise stipulated in the **SCC**, materials and equipment delivered on the site but not completely put in place shall not be included for payment.

15. Operating and Maintenance Manuals

15.1. If required, the Contractor will provide “as built” Drawings and/or operating and maintenance manuals as specified in the **SCC**.

- 15.2. If the Contractor does not provide the Drawings and/or manuals by the dates stated above, or they do not receive the Procuring Entity's Representative's approval, the Procuring Entity's Representative may withhold the amount stated in the **SCC** from payments due to the Contractor.

Section V. Special Conditions of Contract

Notes on the Special Conditions of Contract

Similar to the BDS, the clauses in this Section are intended to assist the Procuring Entity in providing contract-specific information in relation to corresponding clauses in the GCC found in Section IV.

The Special Conditions of Contract (SCC) complement the GCC, specifying contractual requirements linked to the special circumstances of the Procuring Entity, the Procuring Entity's country, the sector, and the Works procured. In preparing this Section, the following aspects should be checked:

- a. Information that complements provisions of the GCC must be incorporated.
- b. Amendments and/or supplements to provisions of the GCC as necessitated by the circumstances of the specific purchase, must also be incorporated.

However, no special condition which defeats or negates the general intent and purpose of the provisions of the GCC should be incorporated herein.

Special Conditions of Contract

GCC Clause	
2	Completion of work shall be within 300 calendar days.
4.1	The Procuring Entity shall give possession of all parts of the Site to the Contractor upon receipt of the Notice to Proceed.
6	The site investigation reports are: <i>[list here the required site investigation reports.]</i>
7.2	<p><i>[Select one, delete the other.]</i></p> <p><i>[In case of permanent structures, such as buildings of types 4 and 5 as classified under the National Building Code of the Philippines and other structures made of steel, iron, or concrete which comply with relevant structural codes (e.g., DPWH Standard Specifications), such as, but not limited to, steel/concrete bridges, flyovers, aircraft movement areas, ports, dams, tunnels, filtration and treatment plants, sewerage systems, power plants, transmission and communication towers, railway system, and other similar permanent structures:]</i> Fifteen (15) years.</p> <p><i>[In case of semi-permanent structures, such as buildings of types 1, 2, and 3 as classified under the National Building Code of the Philippines, concrete/asphalt roads, concrete river control, drainage, irrigation lined canals, river landing, deep wells, rock causeway, pedestrian overpass, and other similar semi-permanent structures:]</i> Five (5) years.</p> <p><i>[In case of other structures, such as bailey and wooden bridges, shallow wells, spring developments, and other similar structures:]</i> Two (2) years.</p>
10	Dayworks are applicable at the rate shown in the Contractor's original Bid.
13	The amount of the advance payment is no more that fifteen percent (15%) of the Contract Price subject to approval by the HOPE and compliance with the conditions under RA 9184 and its IRR.
14	No further instructions.
15.1	<p>The date by which operating and maintenance manuals are required is <i>thirty (30) days</i></p> <p>The date by which "as built" drawings are required as part of final payment</p>
15.2	The amount to be withheld for failing to produce "as built" drawings and/or operating and maintenance manuals by the date required is ten (10%) percent of the contract price.

Section VI. Specifications

Notes on Specifications

A set of precise and clear specifications is a prerequisite for Bidders to respond realistically and competitively to the requirements of the Procuring Entity without qualifying or conditioning their Bids. In the context of international competitive bidding, the specifications must be drafted to permit the widest possible competition and, at the same time, present a clear statement of the required standards of workmanship, materials, and performance of the goods and services to be procured. Only if this is done will the objectives of economy, efficiency, and fairness in procurement be realized, responsiveness of Bids be ensured, and the subsequent task of bid evaluation facilitated. The specifications should require that all goods and materials to be incorporated in the Works be new, unused, of the most recent or current models, and incorporate all recent improvements in design and materials unless provided otherwise in the Contract.

Samples of specifications from previous similar projects are useful in this respect. The use of metric units is mandatory. Most specifications are normally written specially by the Procuring Entity or its representative to suit the Works at hand. There is no standard set of Specifications for universal application in all sectors in all regions, but there are established principles and practices, which are reflected in these PBDs.

There are considerable advantages in standardizing General Specifications for repetitive Works in recognized public sectors, such as highways, ports, railways, urban housing, irrigation, and water supply, in the same country or region where similar conditions prevail. The General Specifications should cover all classes of workmanship, materials, and equipment commonly involved in construction, although not necessarily to be used in a particular Works Contract. Deletions or addenda should then adapt the General Specifications to the particular Works.

Care must be taken in drafting specifications to ensure that they are not restrictive. In the specification of standards for goods, materials, and workmanship, recognized international standards should be used as much as possible. Where other particular standards are used, whether national standards or other standards, the specifications should state that goods, materials, and workmanship that meet other authoritative standards, and which ensure substantially equal or higher quality than the standards mentioned, will also be acceptable. The following clause may be inserted in the SCC.

Sample Clause: Equivalency of Standards and Codes

Wherever reference is made in the Contract to specific standards and codes to be met by the goods and materials to be furnished, and work performed or tested, the provisions of the latest current edition or revision of the relevant standards and codes in effect shall apply, unless otherwise expressly stated in the Contract. Where such standards and codes are national, or relate to a particular country or region, other authoritative standards that ensure a substantially equal or higher quality than the standards and codes specified will be accepted

subject to the Procuring Entity's Representative's prior review and written consent. Differences between the standards specified and the proposed alternative standards shall be fully described in writing by the Contractor and submitted to the Procuring Entity's Representative at least twenty-eight (28) days prior to the date when the Contractor desires the Procuring Entity's Representative's consent. In the event the Procuring Entity's Representative determines that such proposed deviations do not ensure substantially equal or higher quality, the Contractor shall comply with the standards specified in the documents.

These notes are intended only as information for the Procuring Entity or the person drafting the Bidding Documents. They should not be included in the final Bidding Documents.



PROJECT : Proposed Improvement of Tandang Sora Shrine at Banlat Road

LOCATION : Barangay Tandang Sora, District 6, Quezon City

SPECIFICATION

1. GENERAL REQUIREMENTS:

1.0 GENERAL INTENTION- It is the declared and acknowledged intention of the City Government to provide the public and complete the Proposed Improvement of Tandang Sora Shrine at Banlat Road located at Barangay Tandang Sora, District 6, Quezon City, and be ready for use.

1.1 GENERAL DESCRIPTION OF WORK - The contractor shall study the plans and conduct site investigation and inspection of the area in order to familiarize himself with the extent, condition and nature of work involved.

1.2 LIQUIDATED DAMAGES - The time of completion of construction of the project is of essence to the contract. Should the contractor neglect, refuse or fail to complete the construction within time herein provided, then in the event and in view of the difficulty of estimating with exactness the damage caused by delay, the representing agency will compute the liquidated damages as specified on RA 9184 and its implementing rules and regulations.

1.3 SPECIAL CONDITION - Prior to start of work, the contractor shall coordinate with government regarding the removal and disposal of existing materials and structures at the site.

1.4 GENERAL SAFETY- The contractor shall control the generation of dust and flying particles from his operations to prevent creation of nuisance to the public. All materials for construction shall be properly stored and all materials for disposal shall be properly disposed of. The site shall have fence and barricade for safety.

1.5 MATERIALS SUBSTITUTE - Whenever item or class of materials is specified exclusively by trade name, by manufacturers name or by catalogue references, only such item shall be used unless the implementing agency's approval for substitution is secured before using equal quality of materials.

1.6 SHOP DRAWINGS OF REPORT - The contractor shall submit a shop drawing subject for approval of the implementing agency before using or applying to the actual construction.

1.7 PAYMENT - Payment for each accomplished work shall be based on the approved construction contract.

1.8 QUALITY CONTROL - The contractor shall coordinate with the Parks Department to maintain the quality of materials used in the construction. All samples for testing shall be provided by the contractor at no additional cost to the City Government. When test samples fail to meet the specification requirements, the materials represented by the samples shall be replaced and the cost of retesting will be shouldered by the contractor.

2. SITE WORKS:

SCOPE: This section includes the Proposed Improvement of Tandang Sora Shrine at Banlat Road, Barangay Tandang Sora, District 6, Quezon City.

2.0 EARTHFILL:

Filling materials shall be spread and compacted uniformly and shall not to exceed more than the required elevation.

2.1 EXCAVATION:

All excavation works must be according to the required depth as indicated in the approved plan.

2.2 CONCRETE AND MASONRY:

This includes rehabilitation of Tandang Sora sculpture, construction of two-storey multi-purpose building, construction of septic tank, draining canal with concrete cover, utility room and construction of service entrance post, pedestal of park lamp.

MATERIALS:

Portland Cement

Sand ~ washed natural sand or manufactured sand passing a 3mm screen and retained in a no. 100 mesh sieve.

Gravel – shall be crushed G-1 or ¾.

2.3 HARDWARE:

Provide all rough hardware required for the construction works: nails, tie wire, deformed bars, angle bars, c-purlin, flat bar and sagrod as specified in the approved plan.

2.4 CARPENTRY

The Contractor shall furnish and perform all carpentry / woodworks as called for and specified in the plans and should also be subjected to pest control using chlordane.

2.5 FABRICATED MATERIALS:

Provide all fabricated materials as specified and shown on the approved plan.

2.6 ROOFING AND TINSMITHRY:

All roofing materials shall be pre-painted roofing with pre-painted flashing, ridgeroll and other accessories as specified in the approved plan.

2.7 PLUMBING / DRAINAGE SYSTEM:

Provide all drainage/ plumbing works necessary for the completion of the project.

2.8 ELECTRICAL WORKS:

1. All wires must be PHELPS DODGE or its approved equal.
2. Electrical fixtures and accessories shall conform to the approved plan or its approved equal.
3. Service entrance with complete attachments shall be provided for the Meralco application.
4. Park lamps shall conform to the approved plan or its approved equal.

2.9 LANDSCAPING:

The ground shall be leveled before filling with garden soil with a minimum thickness of 4". The plants shall conform to the approved plan.

2.10 PAINTING:

All paints shall meet the required specifications and shall be delivered at the site in the original container. Use Boysen or approved equivalent by the Project Engineer in the execution of the work.

- a) Steel surfaces shall be treated with Red oxide Primer before the application of paint. In general, rough surfaces of concrete shall be properly puttied before any application of paint.
- b) For the final coat, a color scheme shall be provided by the Implementing Agency.

2.11 BILLBOARD:

This item shall include the furnishing of billboard to provide the public of various information regarding the project.

2.12 CLEAN UP:

When the work is completed, the contractor shall remove all temporary structures and surplus materials of every sort, restore what have been removed before leaving and leave the premises or site in good condition as he had originally found them.

2.13 SUBMITTAL REQUIREMENTS:

The contractor, during the progress of work, shall keep careful records of all changes, where the actual installation differs from the shown drawings. Upon completion, the contractor shall in a neat and accurate manner, finalize "AS BUILT" drawings on tracing paper together with the logbook signed by the Contractor's Engineer.

Prepared by:



JOSEPH RYAN A. TUTAY
Project Inspector

Section VII. Drawings

[Insert here a list of Drawings. The actual Drawings, including site plans, should be attached to this section, or annexed in a separate folder.]

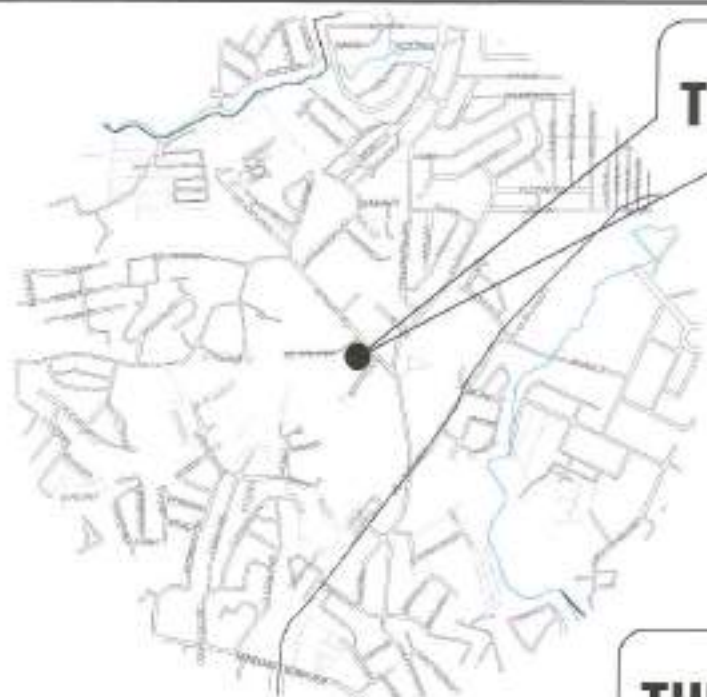

VICINITY MAP

THE SITE

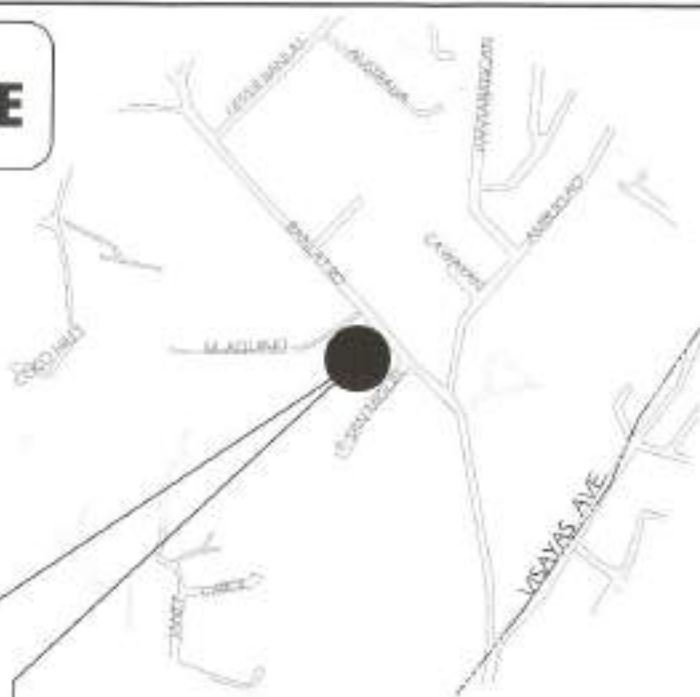

LOCATION MAP

THE SITE



1 PERSPECTIVE
1 SCALE 1:NTS

TABLE OF CONTENT

1	PERSPECTIVE, VICINITY MAP & LOC. MAP
2	SITE DEVELOPMENT PLAN
3	MULTI-PURPOSE BLDG.: GROUND FLOOR PLAN
4	MULTI-PURPOSE BLDG.: SECOND FLOOR PLAN
5	MPB: FRONT & REAR ELEVATION
6	MPB: LEFT-SIDE & RIGHT-SIDE ELEVATION
7	MPB: CROSS SECTION
7	MPB: ROOF PLAN
8	MPB: GRND & 2ND FLR. REFLECTED CEILING PLAN
8	MPB: SECOND FLR. WALL DETAIL 1 & 2
10	MPB: STAIR DETAIL, PLAN & SECTION - A
11	MPB: BALCONY RAILING DETAIL & SECTION - B
12	MPB: TOILET DETAIL, PLAN & SECTION - B
13	MPB: DOORS & WINDOWS SCHEDULE
14	MPB: FOUNDATION PLAN & SCHD. OF FOOTING
	COLUMN & BEAM SCHEDULE
	COLUMN FOOTING SCHEDULE & DET.
15	MPB: SECOND FLOOR FRAMING PLAN
	BEAM & SLAB DETAIL
16	MPB: ROOF FRAMING PLAN & HIF- TRUSS
	TRUSS - 1 & TRUSS DETAIL
17	UTILITY RM: FRONT & REAR ELEVATION
	LEFT-SIDE & RIGHT-SIDE ELEVATION
18	UTILITY RM:
	FOUNDATION PLAN & ROOF FRAMING PLAN
	WALL FOOTING DET. & BEAM DETAIL
	COLUMN/COLUMN FOOTING DET. (CI-F1)
19	LANDSCAPE DEVELOPMENT PLAN
20	LANDSCAPING: KEY PLAN & BLOW UP - A
21	LANDSCAPING: KEY PLAN & BLOW UP - B
22	LIGHTING LAYOUT @ SHRINE & LEGENDS
23	MPB: GROUND & SECOND FLR. LIGHTING LAYOUT
24	MPB: GROUND & SECOND FLR. POWER LAYOUT
25	MPB: GROUND & SECOND FLR. ACU LAYOUT
26	DETAIL OF PANEL & RISER DIAGRAM
27	SCHEDULE OF LOADS
28	GENERAL NOTES & VICINITY MAP
29	MPB: GROUND FLOOR WATERLINE LAYOUT
30	MULTI PURPOSE BLDG.:
	GROUND FLR. SEWAGE/STORM DRAINAGE LAYOUT
	ISOMETRIC: WATER LINE LAYOUT
	SEWAGE/DRAINAGE LAYOUT
	AREA DRAIN/CATCH BASIN DET.

PREPARED BY: 	RECOMMENDING APPROVAL: Arch. NANCY C. ESGUERRA CITY GOVT. DEPARTMENT HEAD	APPROVED BY: Hon. MA. JOSEFINA G. BELMONTE CITY MAYOR	PROJECT TITLE: PROPOSED IMPROVEMENT OF TANDANG SORA SHRINE @ BANLAT RD. LOCATION: WEST TANDANGSORA DIST. 6, QUEZON CITY	SHEET CONTENT: PERSPECTIVE VICINITY MAP LOCATION MAP	NOTED BY: M.S.T. DATE: 11/1/2024 CHECKED BY: M.S.T. DATE: 11/5/24 CADD BY: M.S.T. DATE: 11/1/24	SHEET NO.: 1 30
------------------	---	---	---	---	--	-----------------------

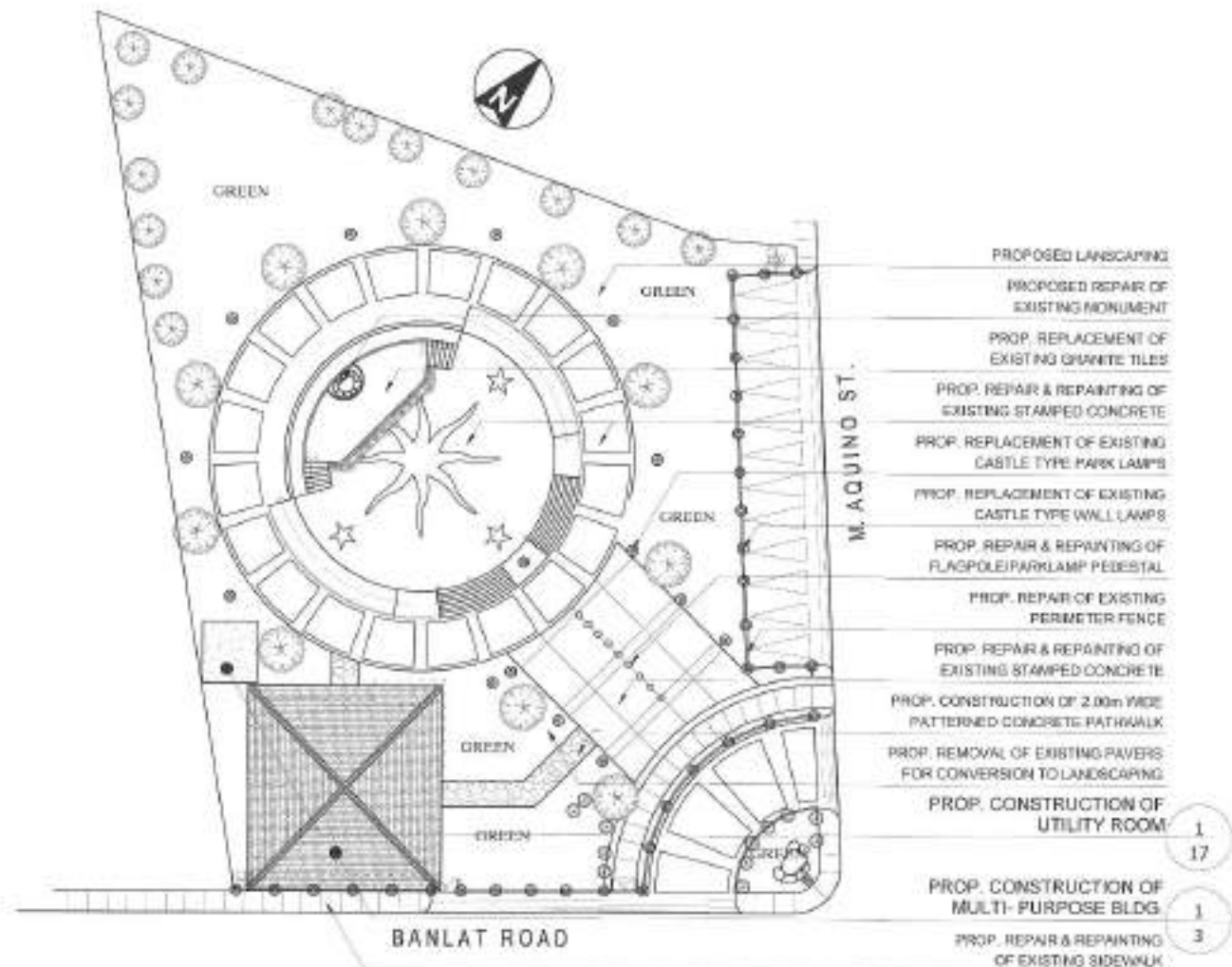

1 SITE DEVELOPMENT PLAN
2 SCALE 1:400

PREPARED BY:	RECOMMENDING APPROVAL:	APPROVED BY:	PROJECT TITLE:	SHEET CONTENT:	NOTED BY: M.S.T.	SHEET NO.:
PARKS DEVELOPMENT & ADMINISTRATION DEPARTMENT	 Arch. NANCY C. ESQUERRA CITY DEPT. DEPARTMENT HEAD II	 Hon. MA. JOSEFINA G. BELMONTE CITY MAYOR	PROPOSED IMPROVEMENT OF TANDANG SORA SHRINE @ BANLAT RD. <small>LOCATION: SHRY TANDANG SORA (SRT & BANLAT CRT)</small>	SITE DEVELOPMENT PLAN	DATE: 11/5/24 CHECKED BY: M.S.T. DATE: 11/5/24 CADD BY: M.S.T. DATE: 11/5/24	2 30

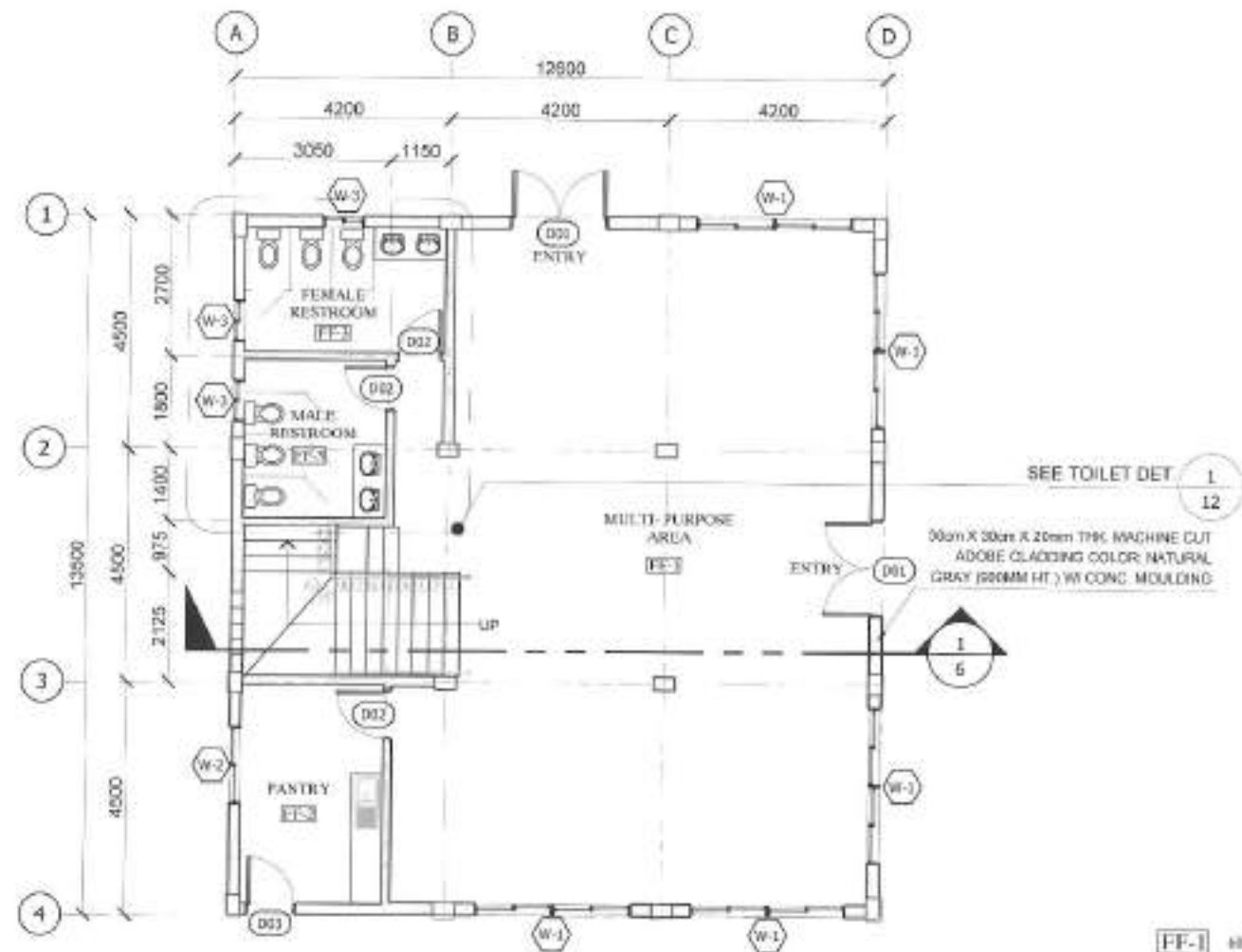

1 **GROUND FLOOR PLAN**
 SCALE 1:100

- FF-1** 60 X 60 CM SYNTHETIC FLOOR GRANITE
- FF-2** 60 X 60 CM HOMOGENOUS TILES
- FF-3** 30 X 30 CM TEXTURED CERAMIC FLOOR TILES
- FF-4** 20 X 120 CM CERAMIC FLOOR TILES IN WOOD LIKE FIN.

PREPARED BY:	RECOMMENDING APPROVAL:	APPROVED BY:	PROJECT TITLE:	SHEET CONTENT:	NOTED BY: J.S.T.	SHEET NO.:
	 Arch. NANCY B. ESQUERRA <small>CITY COMM. DEPARTMENT HEAD</small>	Hon. MA. JOSEFINA G. BELMONTE <small>CITY MAYOR</small>	PROPOSED IMPROVEMENT OF TANDANG SORA SHRINE @ BANLAT RD. <small>REVIEW: ENGR. TAYANG SORA DELA CRUZ DIV.</small>	MULTI PURPOSE BLDG. GROUND FLOOR PLAN	DATE: 11/5/14 CHECKED BY: J.S.T. DATE: 11/5/14 CADD BY: J.S.T. DATE: 11/5/14	3 30

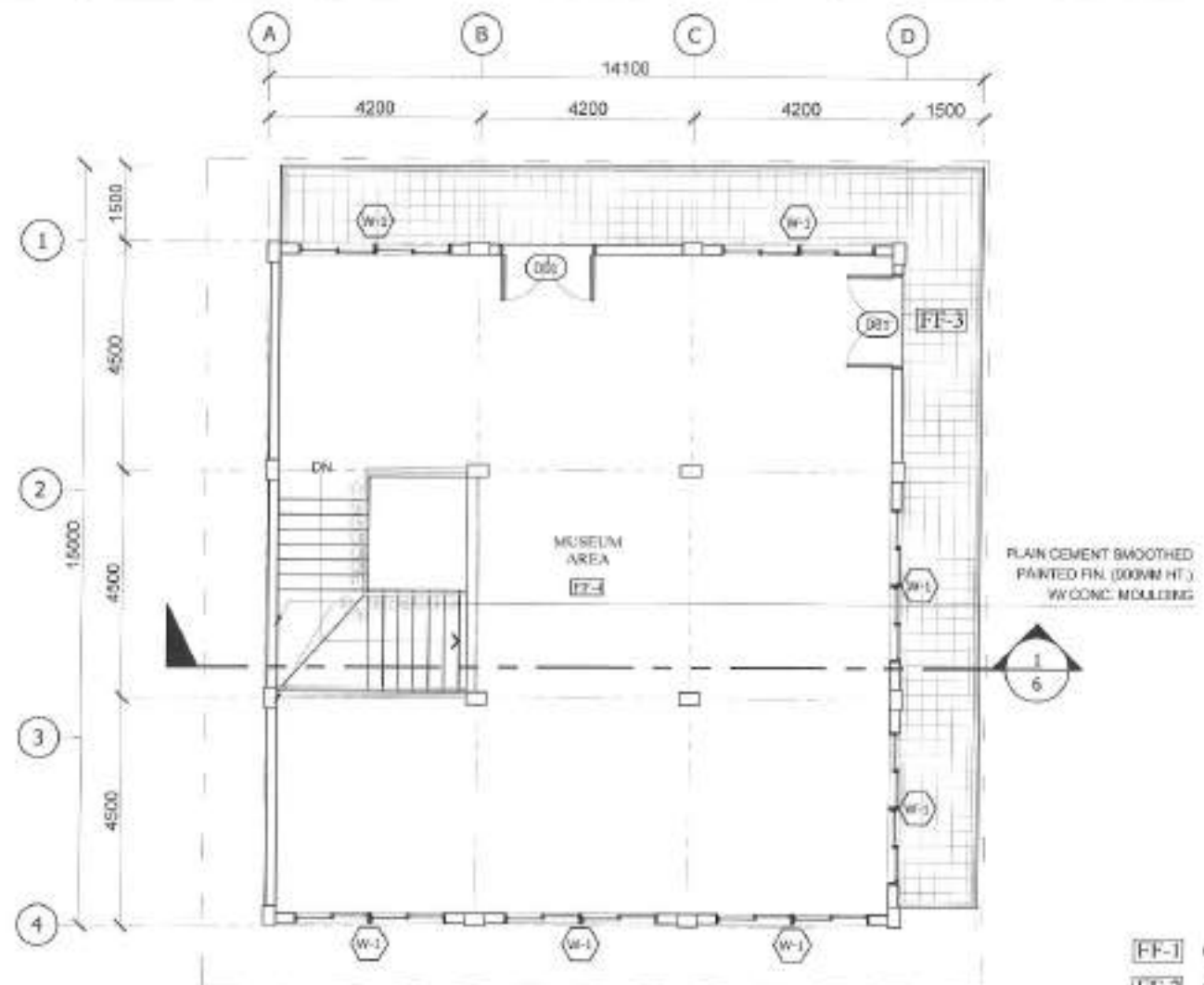

1
4
SECOND FLOOR PLAN
 SCALE 1:100

- FF-1 60 X 60 CM SYNTHETIC FLOOR GRANITE
- FF-2 40 X 60 CM HOMOGENOUS TILES
- FF-3 30 X 30 CM TEXTURED CERAMIC FLOOR TILES
- FF-4 30 X 120 CM CERAMIC FLOOR TILES IN WOOD LIKE FIN.

PREPARED BY: PARKS DEVELOPMENT & ADMINISTRATION DEPARTMENT	RECOMMENDING APPROVAL: Arch. NANCY C. ESCUERRA <small>CITY GOVT. DEPARTMENT HEAD</small>	APPROVED BY: Hon. MA. JOSEFINA G. BELMONTE <small>CITY MAYOR</small>	PROJECT TITLE: PROPOSED IMPROVEMENT OF TANDANG SORA SHRINE @ BANLAT RD. <small>LOKALIN: 3RD TANDANG SORA DIST. & DIVISION: DTI</small>	SHEET CONTENT: MULTI PURPOSE BLDG: SECOND FLOOR PLAN	NOTED BY: S.T. DATE: 11/5/2014 CHECKED BY: S.T. DATE: 11/5/14 CADD BY: DATE: 11/5/14	SHEET NO: <div style="border: 1px solid black; border-radius: 50%; width: 30px; height: 30px; display: flex; align-items: center; justify-content: center; margin: 0 auto;"> 4 30 </div>
---	---	---	--	--	---	--



PREPARED BY:	RECOMMENDING APPROVAL:	APPROVED BY:	PROJECT TITLE:	SHEET CONTENT:	NOTED BY: S.T.	SHEET NO.:
	 Arch. NANCY C. ESCUERRA <small>CITY GOV. DEPARTMENT HEAD</small>	 Hon. MA. JOSEFINA G. BELMONTE <small>CITY MAYOR</small>	PROPOSED IMPROVEMENT OF TANDANG SORA SHRINE @ BANLAT RD. <small>LOCATION: BPO TANDANG SORA ST. & GUBROG</small>	MULTI PURPOSE BLDG. FRONT ELEVATION REAR ELEVATION LEFT-SIDE ELEVATION RIGHT-SIDE ELEVATION	DATE: 11/11/24 CHECKED BY: [Signature] DATE: 11/11/24 CADD BY: [Signature] DATE: 11/11/24	

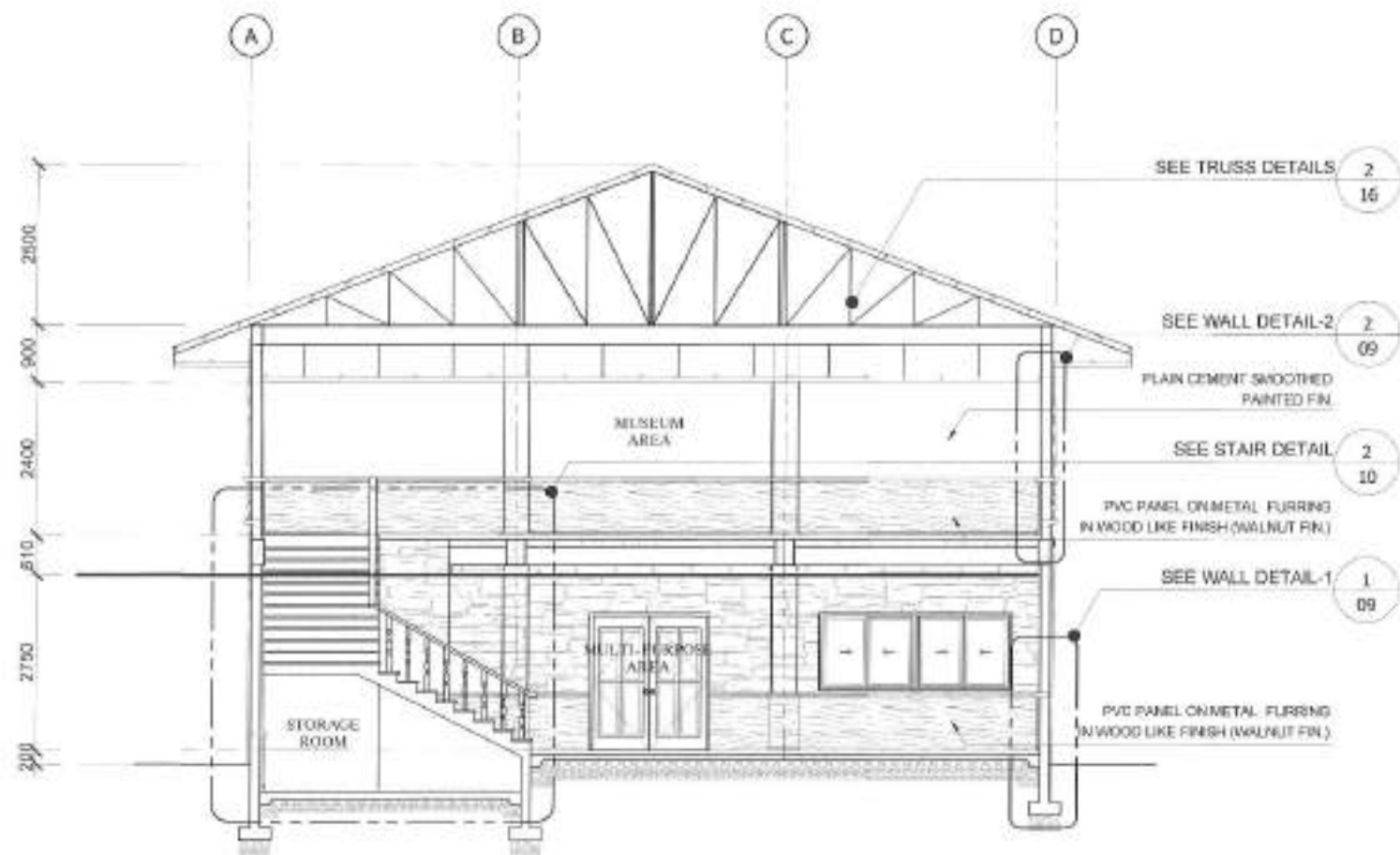

1 CROSS-SECTION
6 SCALE 1:80

PREPARED BY:	RECOMMENDING APPROVAL:	APPROVED BY:	PROJECT TITLE:	SHEET CONTENT:	NOTED BY: A.S.T.	SHEET NO.:
 PARKS DEVELOPMENT & ADMINISTRATION DEPARTMENT	 Arch. NANCY C. ESGUERRA CITY GOVT. DEPARTMENT HEAD	 Hon. MA. JOSEFINA G. BELMONTE CITY MAYOR	PROPOSED IMPROVEMENT OF TANDANG SORA SHRINE @ BANLAT RD. <small>DESIGNED BY: TANDANG SORA DET. S. QUERANCO</small>	MULTI PURPOSE BLDG.: CROSS SECTION	DATE: <i>11/5/24</i>	 6 30
					CHECKED BY: <i>[Signature]</i> DATE: <i>11/5/24</i> CADD BY: <i>[Signature]</i> DATE: <i>11/5/24</i>	

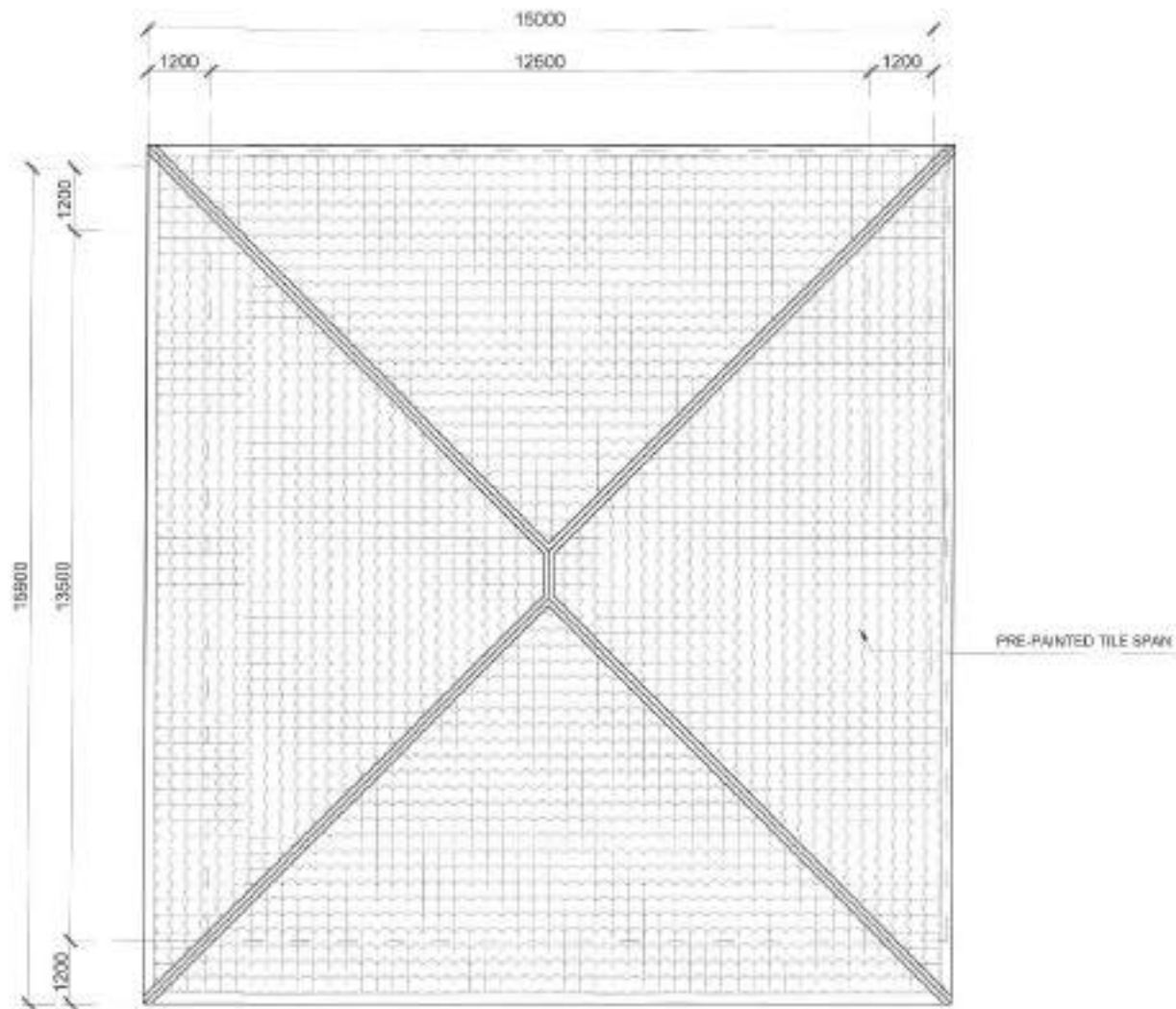

1 ROOF PLAN
7 SCALE 1:100

PREPARED BY:	RECOMMENDING APPROVAL:	APPROVED BY:	PROJECT TITLE:	SHEET CONTENT:	NOTED BY: <i>M.S.T.</i> DATE: <i>11/5/21</i>	SHEET NO.:
 PARKS DEVELOPMENT & ADMINISTRATION DEPARTMENT	 Arch. NANCY C. ESQUERRA <small>CITY ENGINEER</small>	Hon. MA. JOSEFINA G. BELMONTE <small>CITY MAYOR</small>	PROPOSED IMPROVEMENT OF TANDANG SORA SHRINE @ BANLAT RD. <small>PROJECT: TANDANG SORA SHRINE @ BANLAT RD. DIST. & QUEZON CITY</small>	MULTI PURPOSE BLDG. ROOF PLAN CHECKED BY: <i>M.S.T.</i> DATE: <i>11/5/21</i> CADD BY: <i>CPST</i> DATE: <i>11/5/21</i>	 7 30	

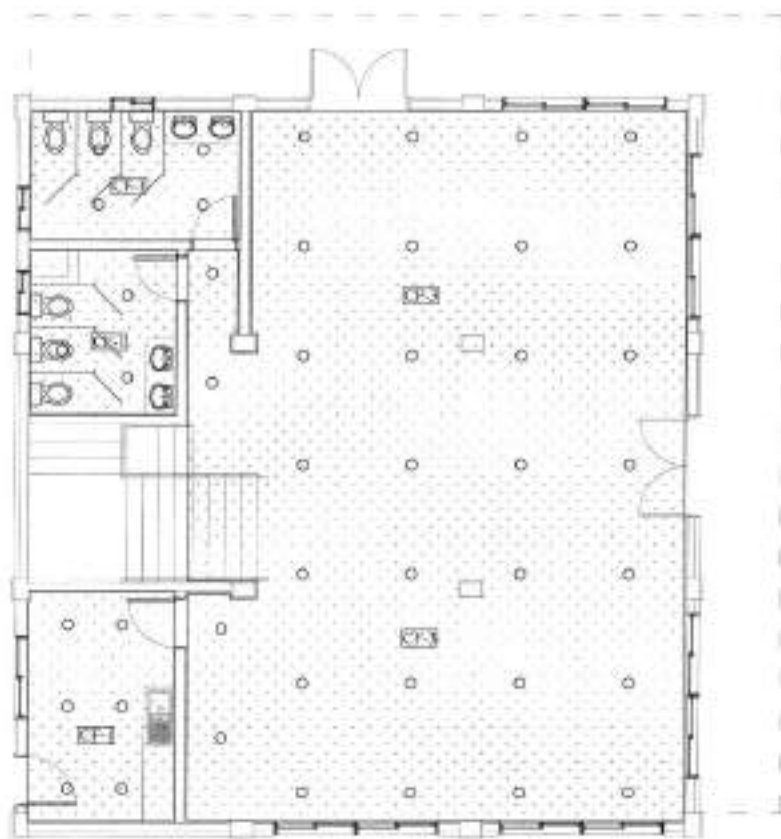

**GROUND FLOOR
REFLECTED CEILING PLAN**

1
8

SCALE

1:100

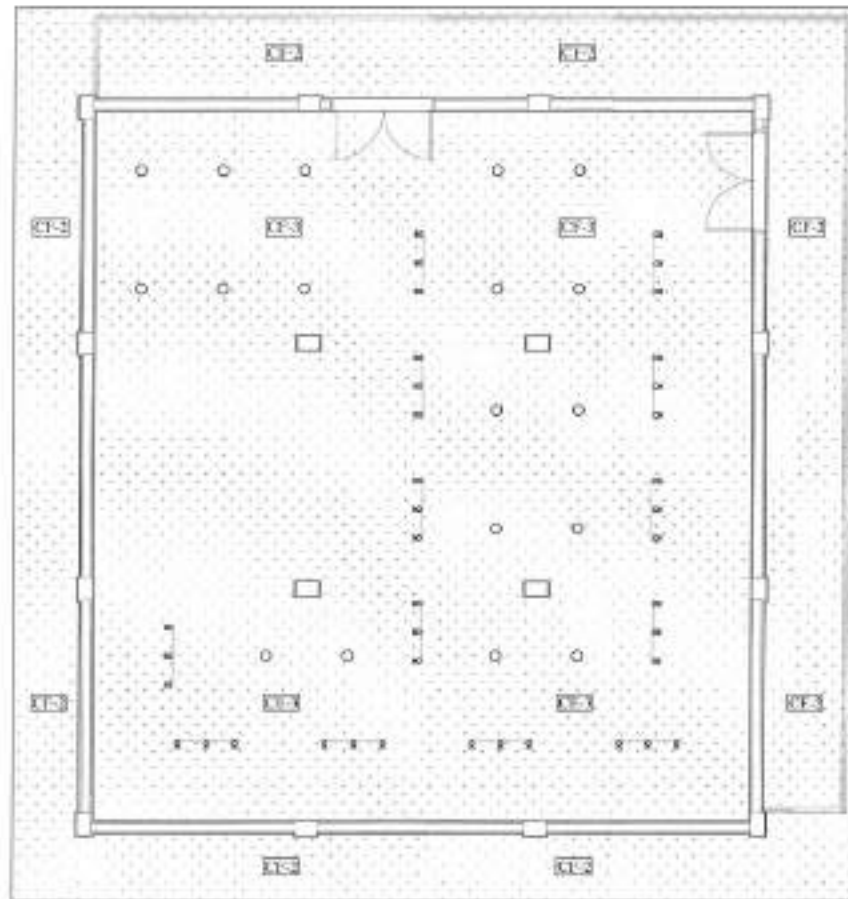

**SECOND FLOOR
REFLECTED CEILING PLAN**

2
8

SCALE

1:100

- CF-1 6mm THK FCBM BOARD PAINTED FIN.
- CF-2 SPANDREL CEILING W/ END MOULDING IN WOOD LIKE FIN.
- CF-3 PVC PANEL W/ END MOULDING ON METAL FURRING IN WOOD LIKE FIN.

PREPARED BY:	RECOMMENDING APPROVAL:	APPROVED BY:	PROJECT TITLE:	SHEET CONTENT:	NOTED BY M.S.T.	SHEET NO.:
 PARKS DEVELOPMENT & ADMINISTRATION DEPARTMENT	 Arch. NANCY C. ESQUERRA CITY GOVT. DEPARTMENT HEAD II	Hon. MA. JOSEFINA G. BELMONTE CITY MAYOR	PROPOSED IMPROVEMENT OF TANDANG SORA SHRINE @ BANLAT RD. <small>LOCATION: BRGY. TANDANG SORA, DIST. 6, QUEZON CITY.</small>	MULTI PURPOSE BLDG. GROUND FLOOR REFLECTED CEILING PLAN SECOND FLOOR REFLECTED CEILING PLAN	DATE: 11/10/24 CHECKED BY: M.S.T. DATE: 11/11/24 CADD BY: M.S.T. DATE: 11/11/24	8 30

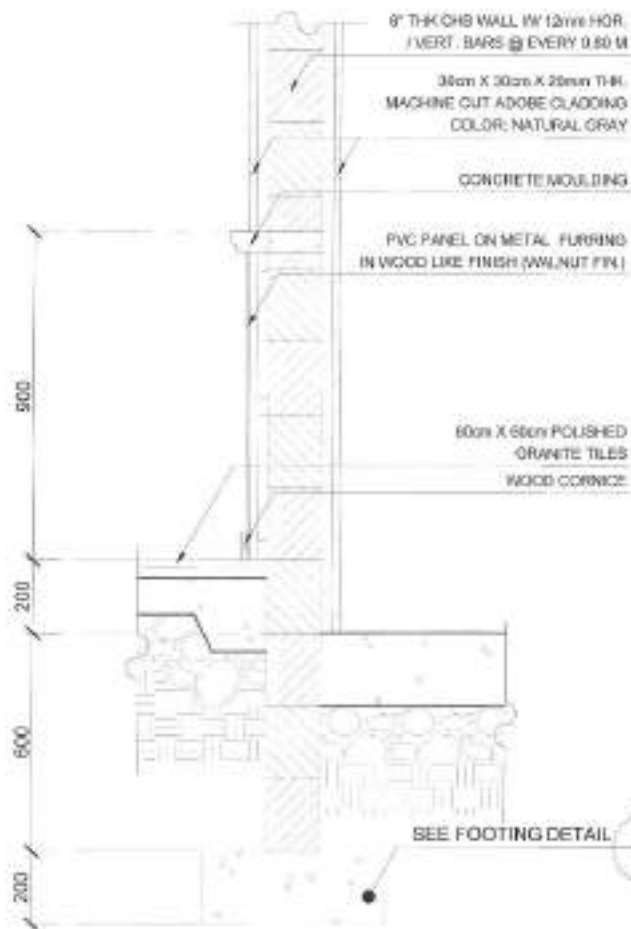

GROUND FLOOR
WALL DETAIL-1
 1
 9 SCALE 1:15

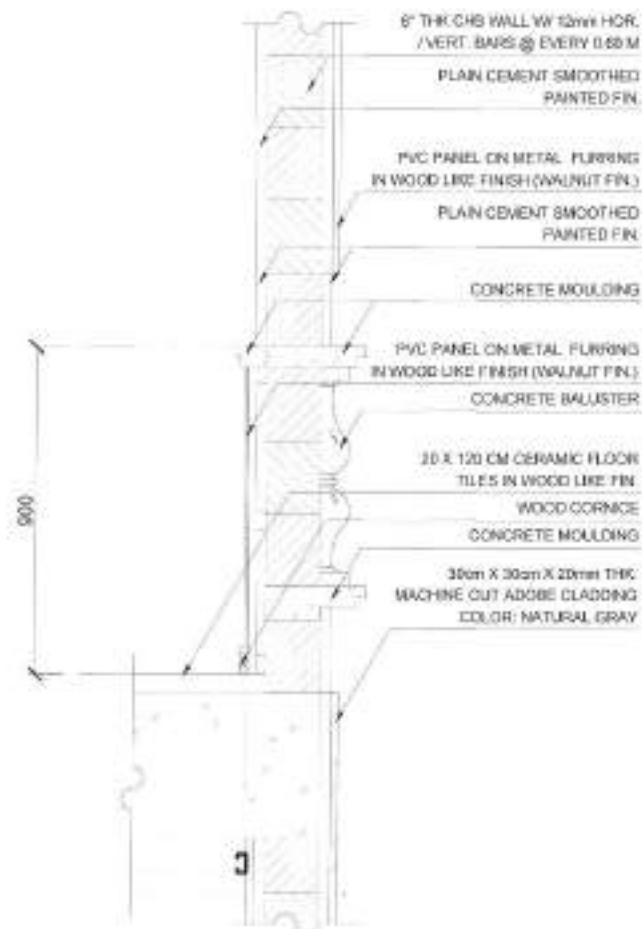

SECOND FLOOR
WALL DETAIL-2
 2
 9 SCALE 1:15

PREPARED BY:	RECOMMENDING APPROVAL:	APPROVED BY:	PROJECT TITLE:	SHEET CONTENT:	NOTED BY: <i>EST</i>	SHEET NO.:
	 Arch. NANCY C. ESGUERRA <small>CITY GOVT. DEPARTMENT HEAD</small>	 Hon. MA. JOSEFINA G. BELMONTE <small>CITY GOVT. DEPARTMENT</small>	PROPOSED IMPROVEMENT OF TAWDANG SORA SHRINE @ BANLAT RD. <small>LOCATION: BPOY, TAWDANG SORA, DIST. S. QUEZON CITY</small>	MULTI PURPOSE BLDG.: GROUND FLOOR WALL DETAIL-1 SECOND FLOOR WALL DETAIL-2	DATE: <i>11/1/2017</i> CHECKED BY: <i>EST</i> DATE: <i>11/1/17</i> CADD BY: <i>EST</i> DATE: <i>11/1/17</i>	
					PARKS DEVELOPMENT & ADMINISTRATION DEPARTMENT	

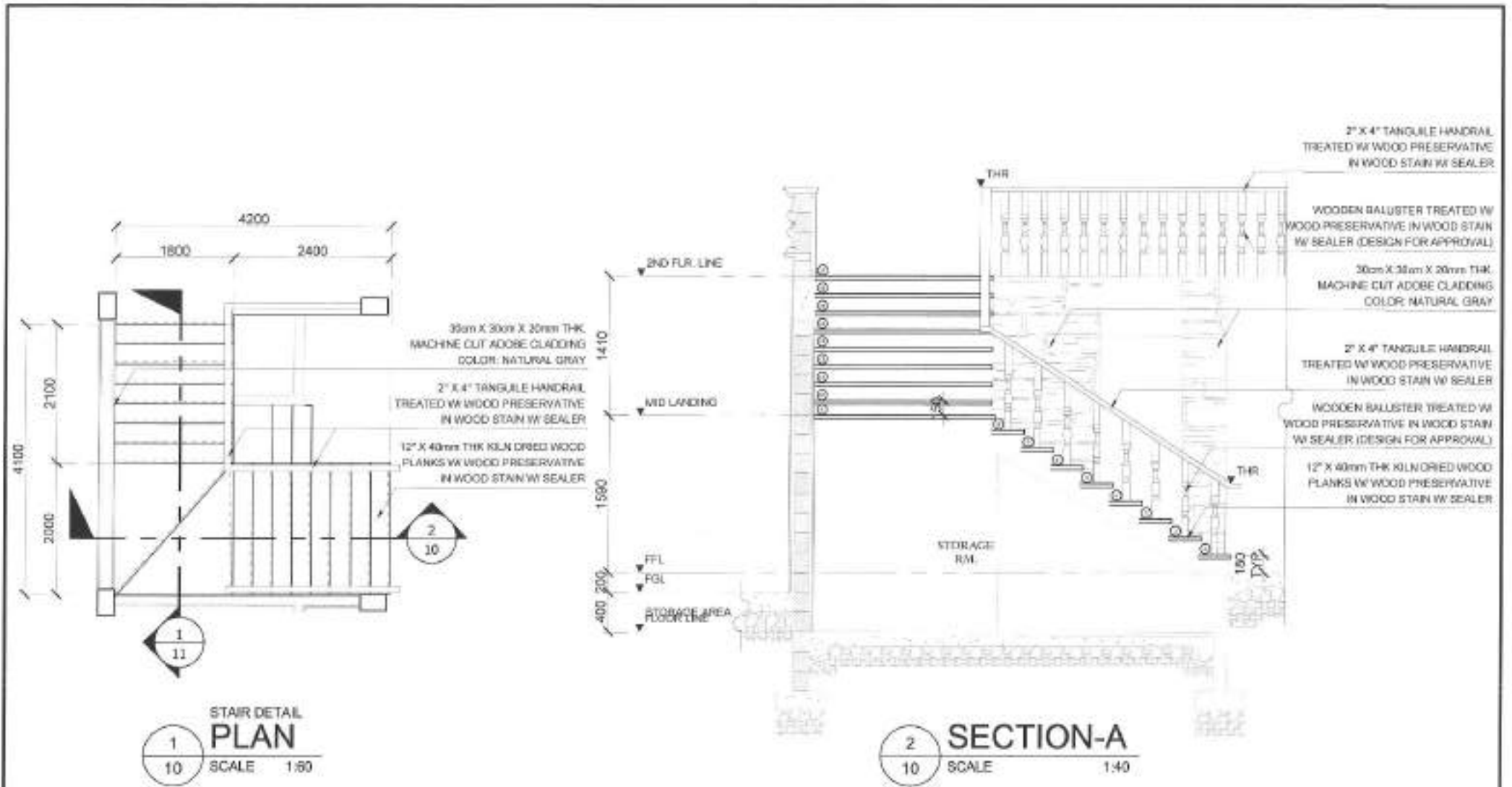

PREPARED BY:	RECOMMENDING APPROVAL:	APPROVED BY:	PROJECT TITLE:	SHEET CONTENT:	NOTED BY: M.S.T.	SHEET NO.:
<p>PARKS DEVELOPMENT & ADMINISTRATION DEPARTMENT</p>	<p>Arch. NANCY G. ESGUERRA CITY SCPT. DEPARTMENT 1942-B</p>	<p>Hon. MA. JOSEFINA G. BELMONTE CITY MAYOR QUINCI CITY</p>	<p>PROPOSED IMPROVEMENT OF TANDANG SCORA SHRINE @ BANLAT RD.</p> <p>LOCATION: BRD. TANDANG SCORA DRT & QUINCI CITY</p>	<p>PLATE PURPOSE BLDG: STAIR DETAIL PLAN SECTION - A</p>	DATE: 11/15/2024	<p>10 30</p>
					CHECKED BY: M.S.T.	
					CADD BY: M.S.T.	
					DATE: 11/15/24	

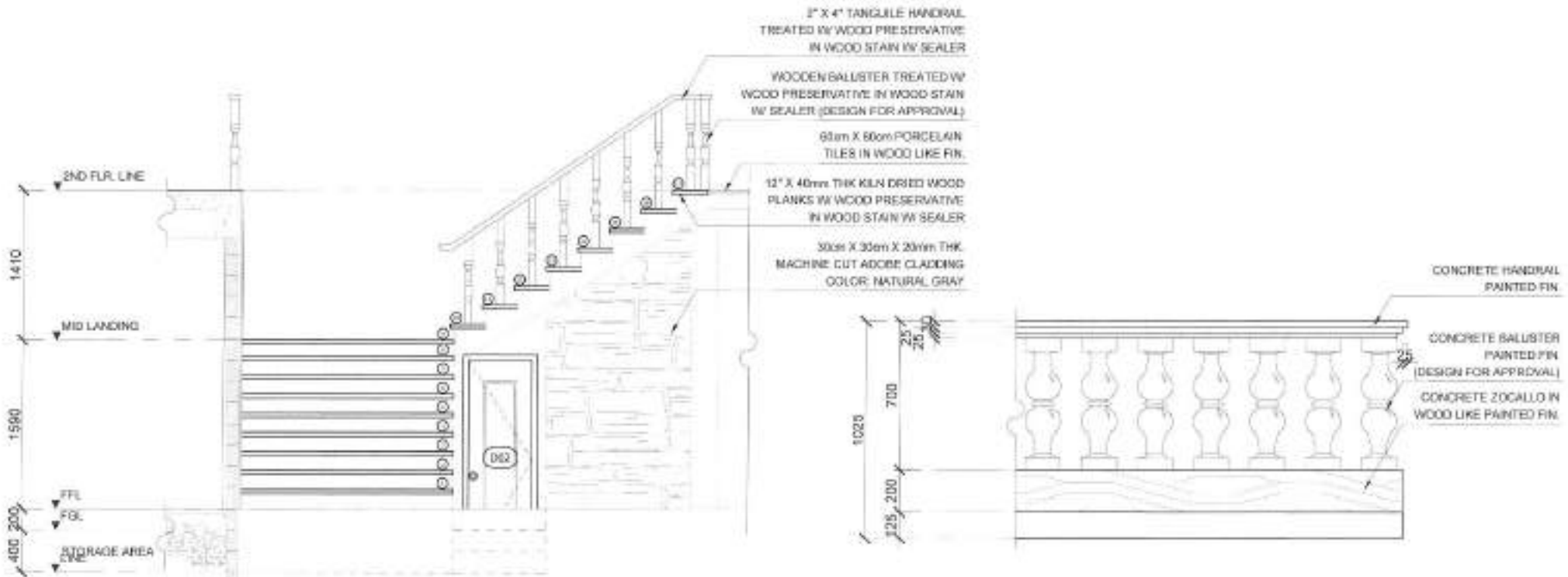

1 SECTION-B
11 SCALE 1:40

2 BALCONY RAILING DET.
11 SCALE 1:20

PREPARED BY:	RECOMMENDING APPROVAL:	APPROVED BY:	PROJECT TITLE:	SHEET CONTENT:	NOTED BY: <i>[Signature]</i> S.T.	SHEET NO.:
	 Arch. NANCY C. ESGUERRA <small>CITY GOVT. DEPARTMENT HEAD</small>	 Hon. MA. JOSEFINA G. BELMONTE <small>CITY GOVERNOR QUEZON CITY</small>	PROPOSED IMPROVEMENT OF TANDANG SORA SHRINE @ BANLAT RD. <small>LOCATION: BRGY. TANDANG SORA, DIST. & QUEZON CITY</small>	MULTI PURPOSE BLDG. 1	DATE: <i>[Handwritten]</i>	
				SECTION - B	CHECKED BY: <i>[Signature]</i>	
				BALCONY RAILING DETAIL	DATE: <i>[Handwritten]</i>	
					DATE: <i>[Handwritten]</i>	

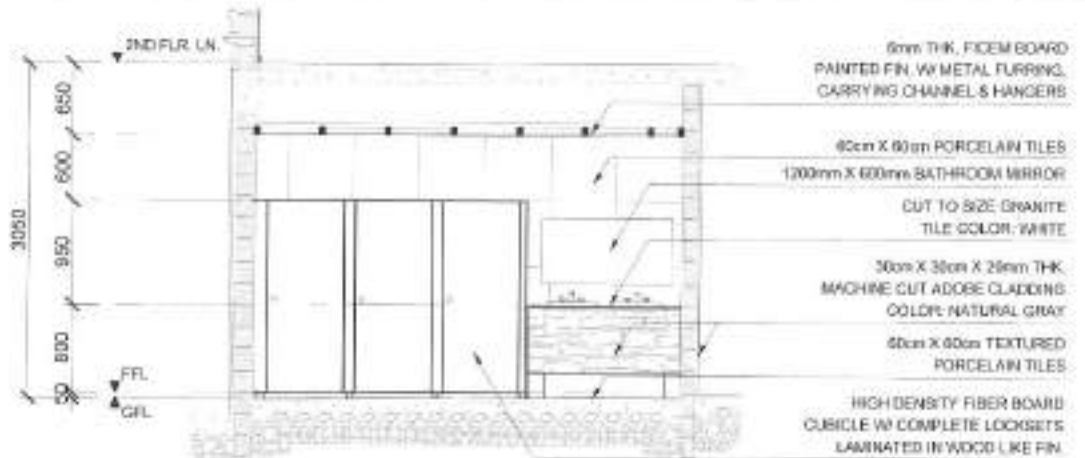
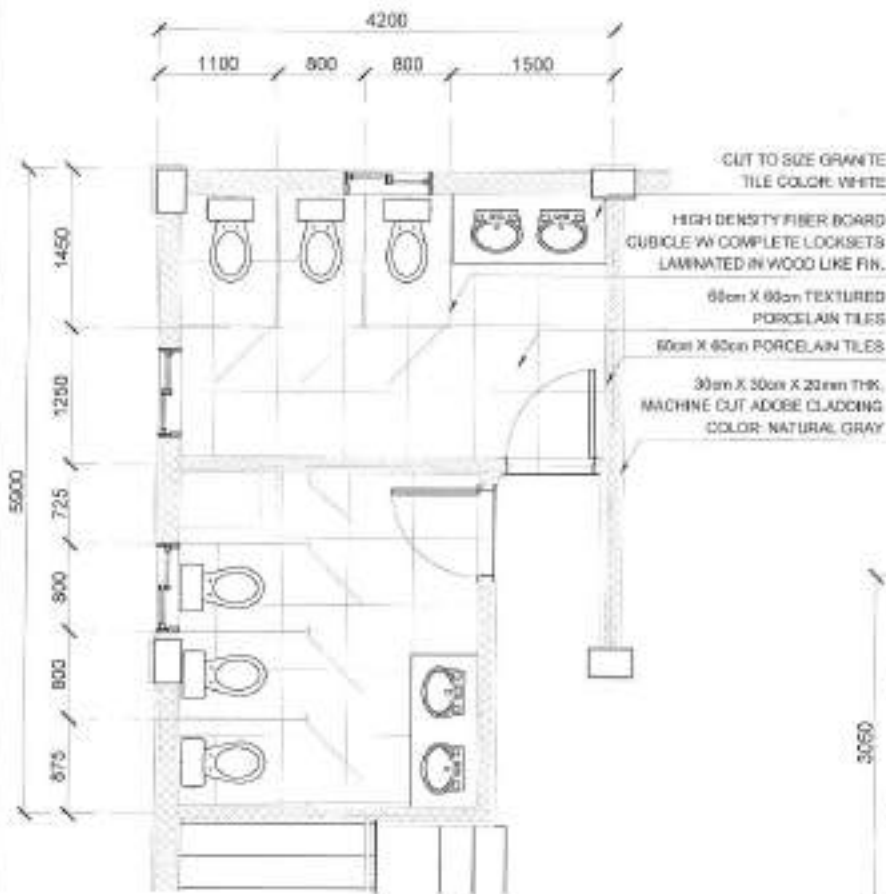

PREPARED BY:	RECOMMENDING APPROVAL:	APPROVED BY:	PROJECT TITLE:	SHEET CONTENT:	NOTED BY: <i>M.S.T.</i>	SHEET NO.:
			PROPOSED IMPROVEMENT OF TANDANG SORA SHRINE @ BANLAT RD.	MULTI PURPOSE BLDG. TOILET DETAIL PLAN SECTION - B	DATE: <i>11/20/14</i>	12 30
	Arch. NANCY C. ESQUERRA CITY GOVT. DEPARTMENT HEAD	Hon. MA. JOSEFINA G. BELMONTE CITY MAYOR	Location: BPO TANDANG SORA (BT & QUEEN CITY)		CHECKED BY: <i>[Signature]</i>	
					DATE: <i>11/25/14</i>	

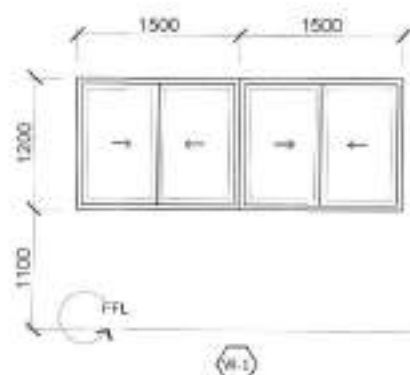

POWDER COATED SLIDING WINDOW W/
8mm THK TEMPERED GLASS W/
COMPLETE ACCESSORIES

SET: 12
LOCATION: MULTI-PURPOSE AREA

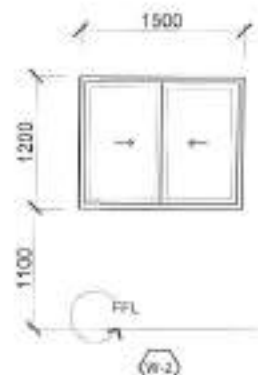

POWDER COATED SLIDING WINDOW
W/ 8mm THK TEMPERED GLASS W/
COMPLETE ACCESSORIES

SET: 1
LOCATION: PANTRY

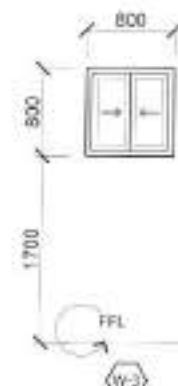

POWDER COATED SLIDING WINDOW W/
8mm THK TEMPERED GLASS W/
COMPLETE ACCESSORIES

SET: 5
LOCATION: RESTROOMS



45mm THK SWING TYPE POWDER
COATED STEEL DOOR (WOOD LIKE FIN.)

SETS: 4
LOCATION: RWIN ENTRANCES, BALCONY



45mm THK SWING TYPE WOODEN
FLUSH DOOR

SETS: 3
LOCATION: RESTROOMS, LOCKER RM,
PANTRY



45mm THK SWING TYPE POWDER
COATED STEEL DOOR IN WOOD LIKE FIN.

SETS: 1
LOCATION: PANTRY



DOORS & WINDOWS SCHEDULE

SCALE

1:50

SCALE 1:50

PREPARED BY:	RECOMMENDING APPROVAL:	APPROVED BY:	PROJECT TITLE:	SHEET CONTENT:	NOTED BY: <i>AST</i>	SHEET NO.
	 Arch. NANCY C. ESGUERRA <small>CITY GOV. DEPARTMENT HEAD</small>	 Hon. MA. JOSEFINA G. BELMONTE <small>CITY MAJOR</small>	PROPOSED IMPROVEMENT OF TANDANG SORA SHRINE @ BANLAT RD. <small>LOCATION: BPOY, TANDANG SORA DIST. & QUEZON CITY</small>	MULTI-PURPOSE BLDG.: DOORS & WINDOWS SCHEDULE	DATE: <i>11/5/2021</i>	
					CHECKED BY: <i>AST</i> DATE: <i>11/5/21</i> CADD BY: <i>AST</i> DATE: <i>11/5/21</i>	

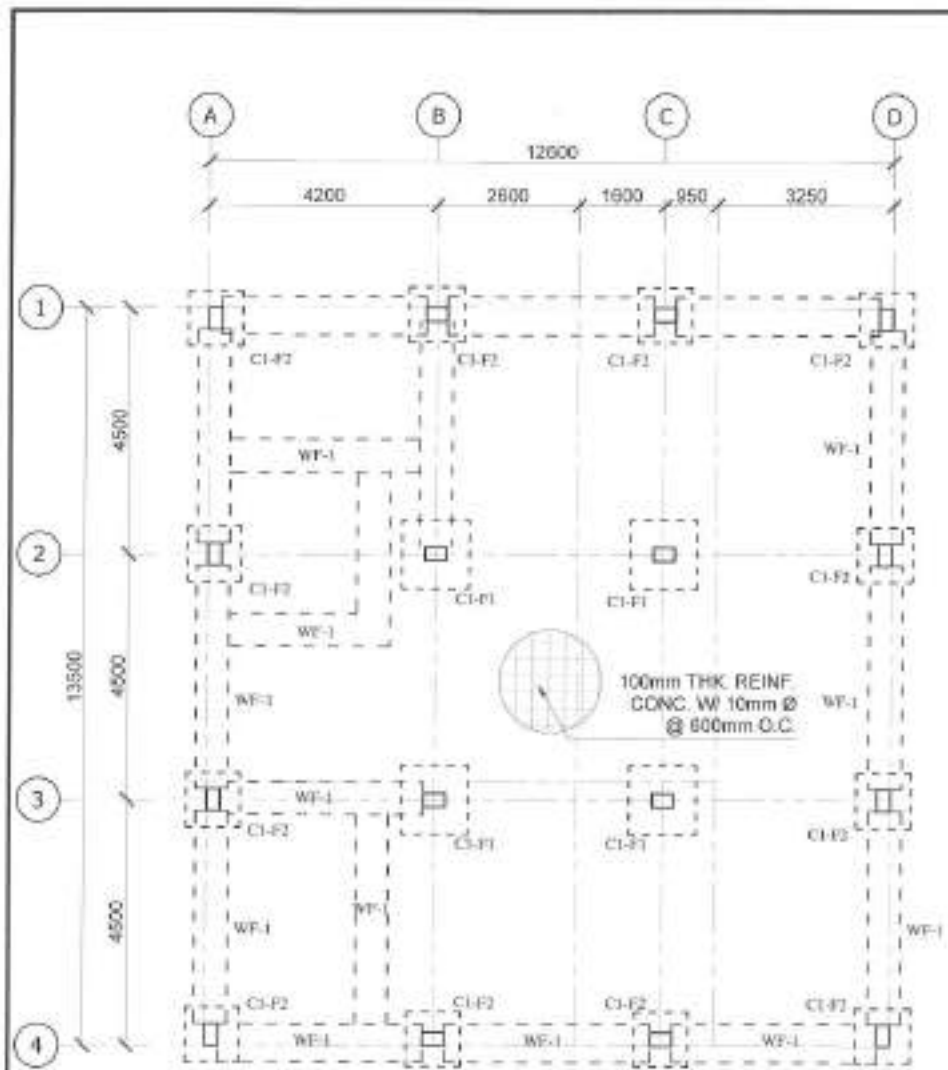

1 FOUNDATION PLAN
14 SCALE 16

SCHEDULE OF FOOTING						
FOOTING MARK	SIZE BXH (mm)	DEPTH D (mm)	THICKNESS T(mm)	REINFORCEMENT		REMARKS
				a	b	
F1	1250 X 1250	1200	280	7-16 Ø	7-16 Ø	SQUARE
F2	1000 X 1000	1200	280	6-16 Ø	6-16 Ø	SQUARE

COLUMN SCHEDULE				
COLUMN MARK	SIZE BXH (mm)	FOOTING TO 2ND FLR	2ND FLR TO ROOF BEAM	10 MM Ø TIES (MM)
C-1	250 X 400	8 - 16 Ø	6 - 16 Ø	2-10 Ø SPACED 2 @ 50, 6 @ 100, REST @ 150mm O.C.

BEAM SCHEDULE				
BEAM MARK	SIZE (mm)	STEEL REINFORCEMENT, mm		STIRRUPS
		SUPPORT	MID-SPAN	
B-1	200 X 400	6 - 16 Ø 3 - 16 Ø	2 - 16 Ø 5 - 16 Ø	2 @ 50, 6 @ 100 REST @ 150mm O.C.
B-2	200 X 400	4 - 16 Ø 2 - 16 Ø	2 - 16 Ø 3 - 16 Ø	2 @ 50, 4 @ 100, REST @ 150 mm O.C.
RB	180 X 300	2 - 16 Ø 2 - 16 Ø	2 - 16 Ø 2 - 16 Ø	2 @ 50, REST @ 150 mm O.C.
CB-1	200 X 400	4 - 16 Ø 2 - 16 Ø		2 @ 50, REST @ 150 mm O.C.

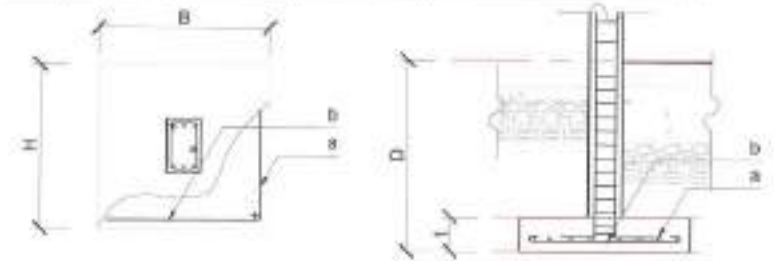

2 COLUMN/ FOOTING SCHEDULE & DET.
14 SCALE 1:NTS

PREPARED BY: 	RECOMMENDING APPROVAL: Arch. NANCY G. EBGUERRA CITY ENGINEER, DEPARTMENT HEAD	APPROVED BY: Hon. MA. JOSEFINA G. BELMONTE CITY MAYOR	PROJECT TITLE: PROPOSED IMPROVEMENT OF TANDANG SORA SHRINE @ BANLAT RD. LOCATION: BRG. TANDANG SORA, DIST. B. QUEZON CITY	SHEET CONTENT: MULTI-PURPOSE BLDG. FOUNDATION PLAN SCHEDULE OF FOOTING COLUMN SCHEDULE COLUMN FOOTING SCHEDULE & DET.	NOTED BY: DATE: 11/3/2021 CHECKED BY: DATE: 11/3/21 CADD BY: DATE: 11/3/21	SHEET NO.: 14 30
------------------	---	---	---	--	---	------------------------

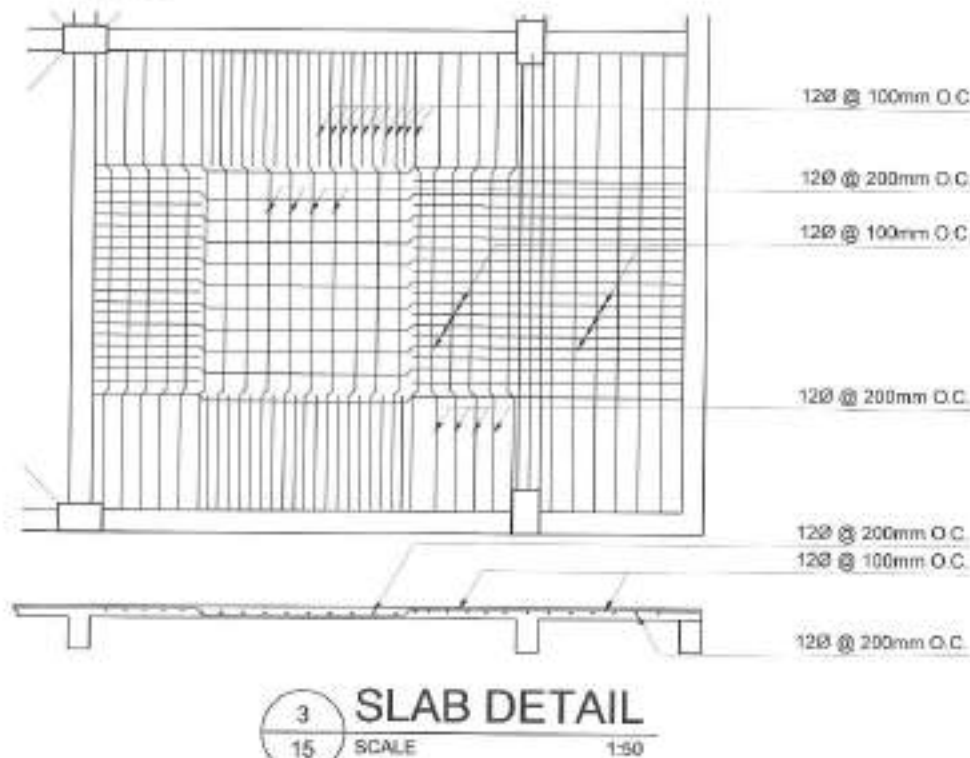
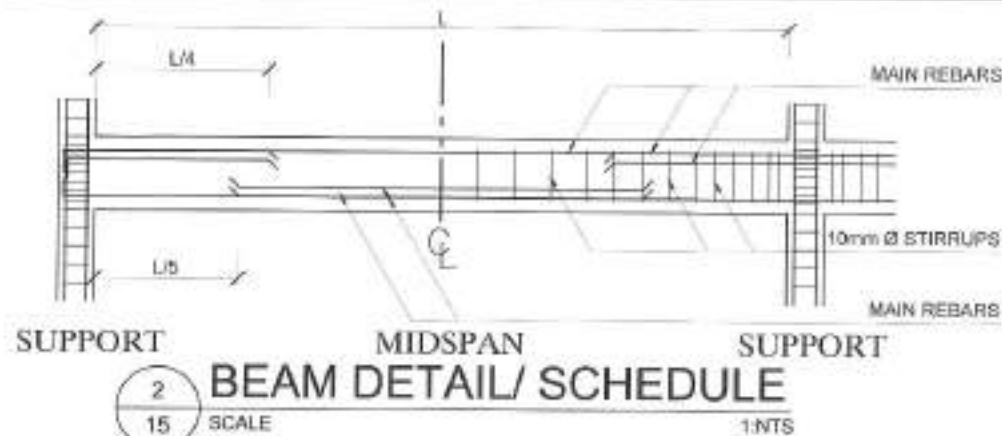
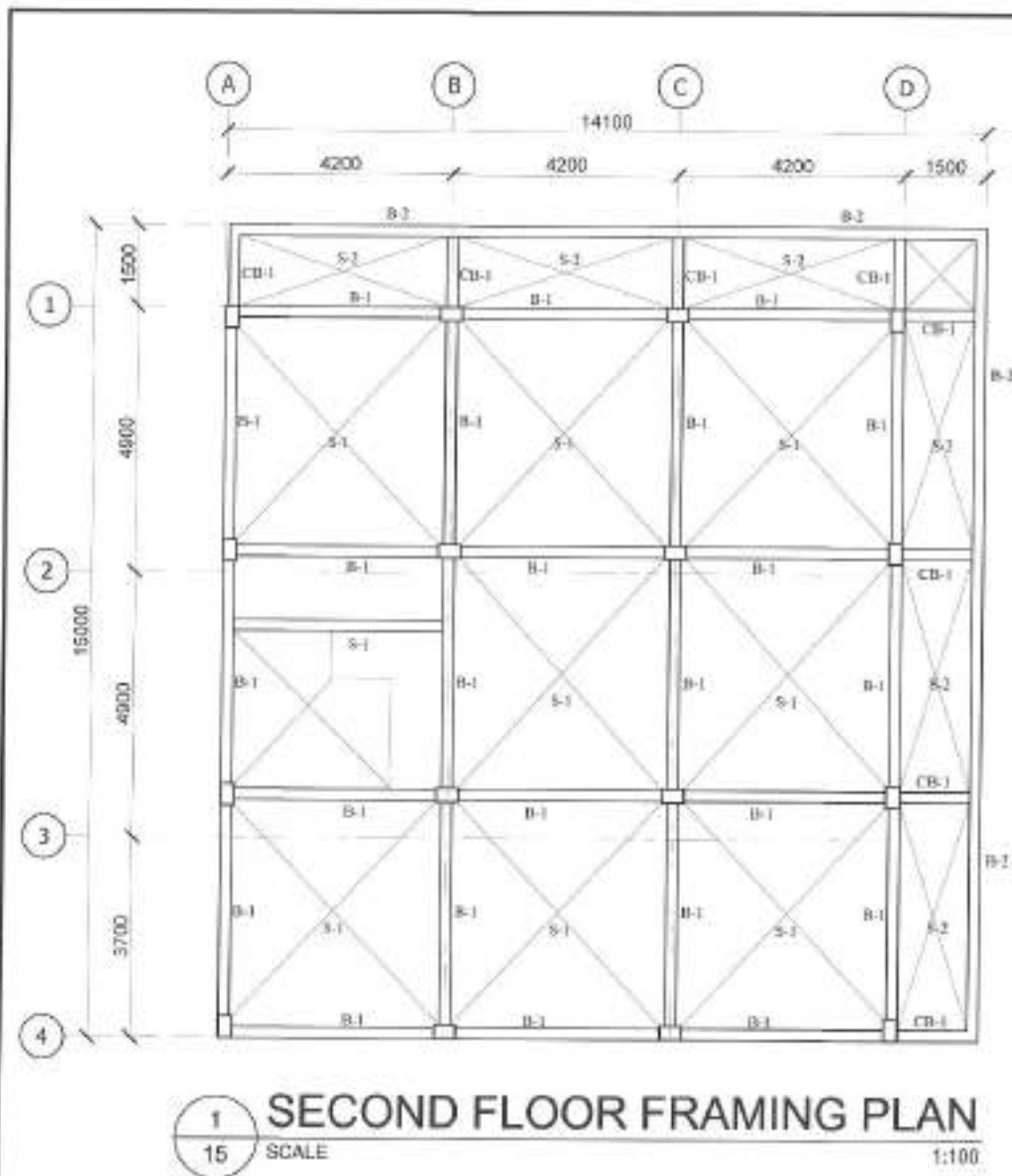

PREPARED BY:  PARKS DEVELOPMENT & ADMINISTRATION DEPARTMENT	RECOMMENDING APPROVAL:  Arch. NANCY G. ESQUERRA CITY GOV. DEPARTMENT-EDS	APPROVED BY: Hon. MA. JOSEFINA G. BELMONTE CITY MAYOR	PROJECT TITLE: PROPOSED IMPROVEMENT OF TANDANG SCRA SHRINE @ BANLAT RD.	SHEET CONTENT: MULTI-PURPOSE B.D.G.- SECOND FLOOR FRAMING PLAN BEAM DETAIL/ SCHEDULE	NOTED BY: M.S.T. DATE: 10/12/2021 CHECKED BY: M.S.T. DATE: 10/12/2021 CADD BY: C.M.S. DATE: 01/01/2021	SHEET NO.: 15 30
--	---	--	---	--	---	-------------------------------

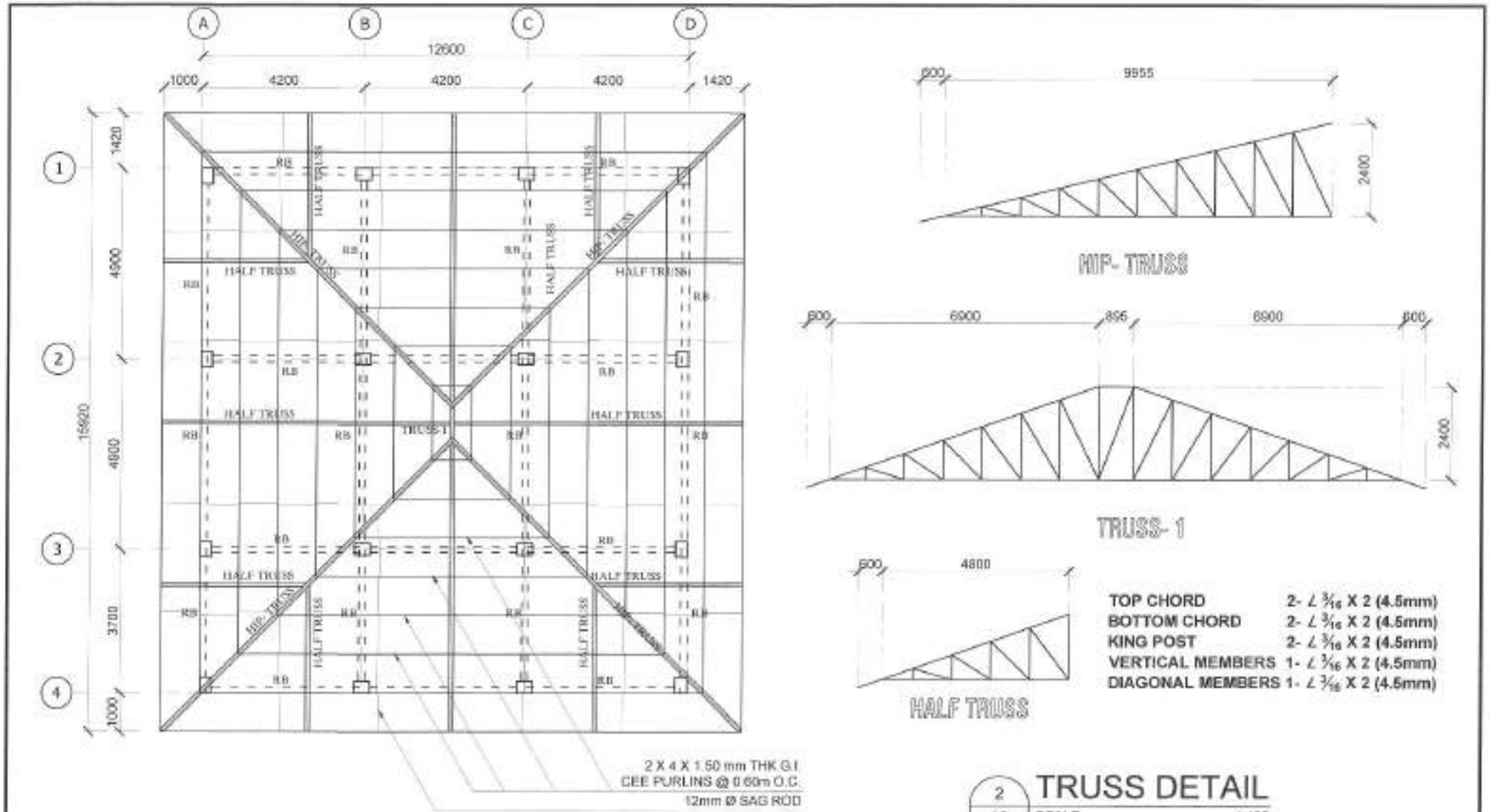

PREPARED BY:	RECOMMENDING APPROVAL:	APPROVED BY:	PROJECT TITLE:	SHEET CONTENT:	NOTED BY: <i>[Signature]</i> S.T.	SHEET NO.:
PARKS DEVELOPMENT & ADMINISTRATION DEPARTMENT	 Arch. NANCY C. ESQUERRA CITY GOVT. DEPARTMENT HEAD	Hon. MA. JOSEFINA G. BELMONTE CITY MAYOR	PROPOSED IMPROVEMENT OF TANJANG SORA SHRINE @ BANLAT RD. LOCATION: BRGY. TANJANGSORA, DIST. & DIVISION CITY	MULTI-PURPOSE BLDG: ROOF FRAMING PLAN HSP-TRUSS TRUSS-1 TRUSS DETAIL	DATE: <i>11/5/2021</i> CHECKED BY: <i>[Signature]</i> S.T. DATE: <i>11/5/21</i> CADD BY: <i>[Signature]</i> S.T. DATE: <i>11/5/21</i>	16 30

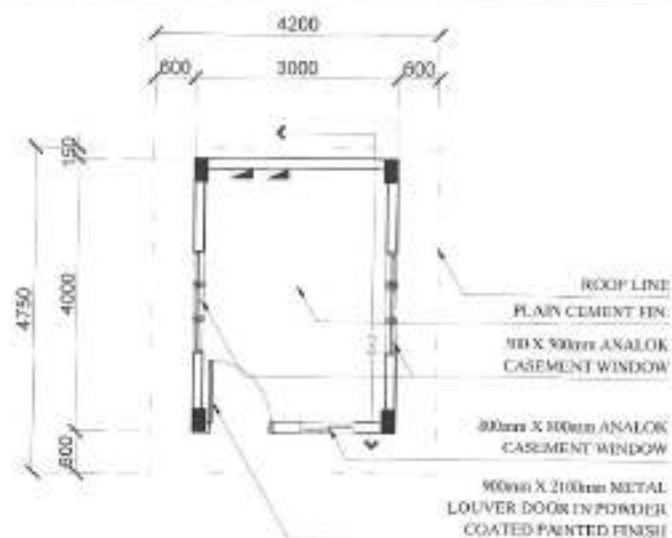

1
17 SCALE 1:80
UTILITY ROOM FLOOR PLAN

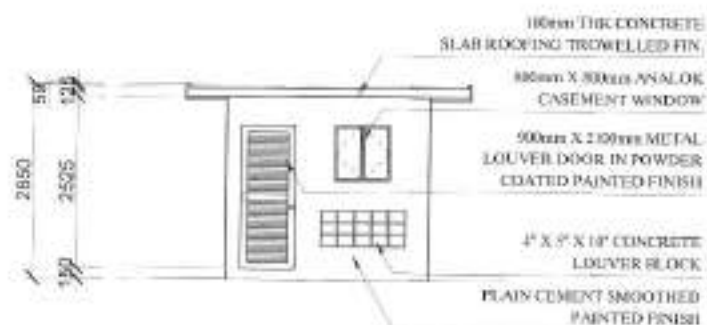

2
17 SCALE 1:80
FRONT ELEVATION



3
17 SCALE 1:80
LEFT-SIDE ELEVATION

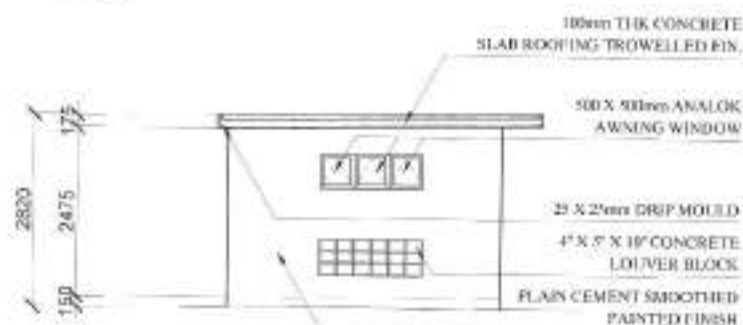

4
17 SCALE 1:80
LEFT-SIDE ELEVATION

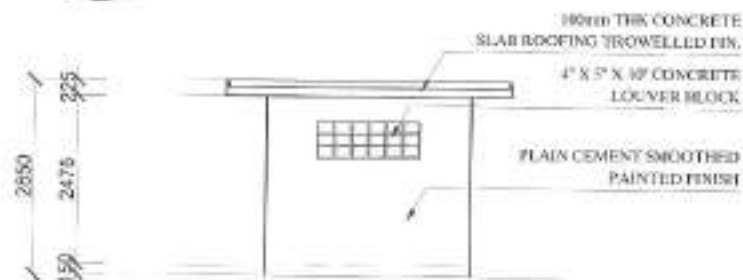

5
17 SCALE 1:80
REAR ELEVATION

PREPARED BY:	RECOMMENDING APPROVAL:	APPROVED BY:	PROJECT TITLE:	SHEET CONTENT:	NOTED BY:	SHEET NO.:
	 Arch. NANCY O. ESQUERRA CITY GOVT. DEPARTMENT HEAD	 Hon. MA. JOSEFINA G. BELMONTE CITY MAYOR	PROPOSED IMPROVEMENT OF TANDANG SORA SHRINE @ BANLAT RD. LOCATION: BPO TANDANG SORA DIST. 5, BUELOS ST.	UTILITY ROOM: FRONT ELEVATION REAR ELEVATION LEFT-SIDE ELEVATION RIGHT-SIDE ELEVATION	DATE: 11/5/14 CHECKED BY: [Signature] DATE: 11/5/14 CADD BY: [Signature] DATE: 11/5/14	17 30

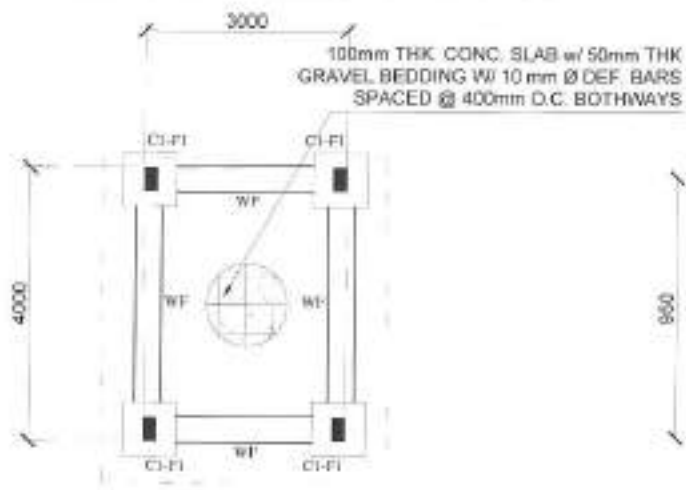

1 FOUNDATION PLAN
SCALE 1:80

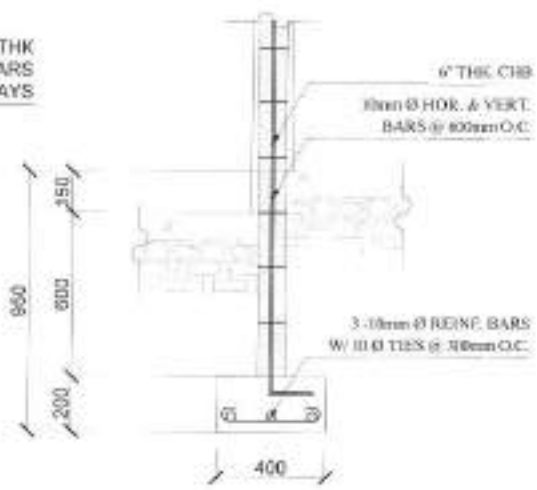

2 WALL FOOTING DET.
SCALE 1:20

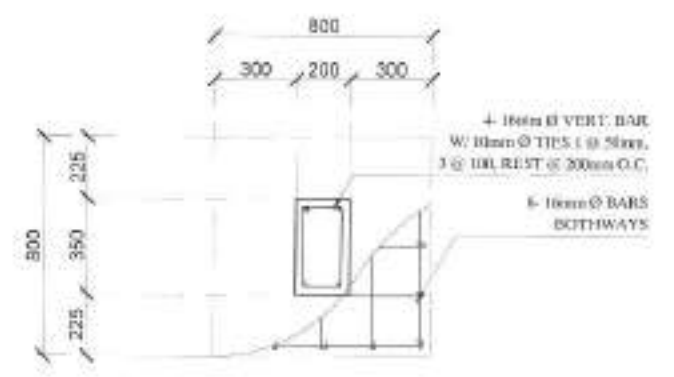

5 COLUMN/COLUMN FOOTING DETAIL PLAN (C1-F1)
SCALE 1:20

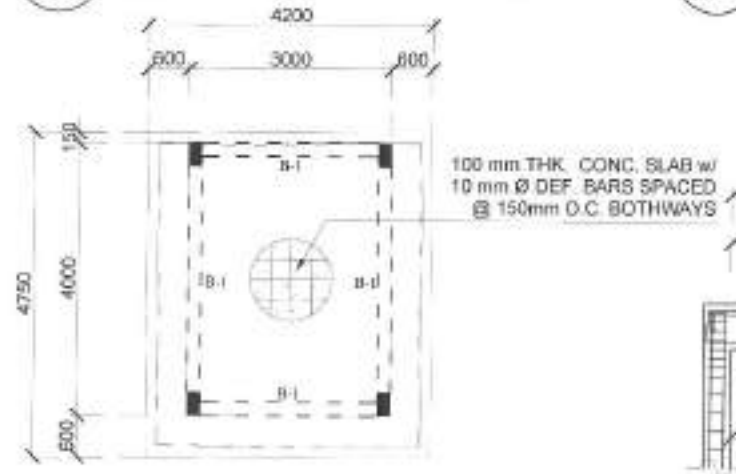

3 ROOF FRAMING PLAN
SCALE 1:80

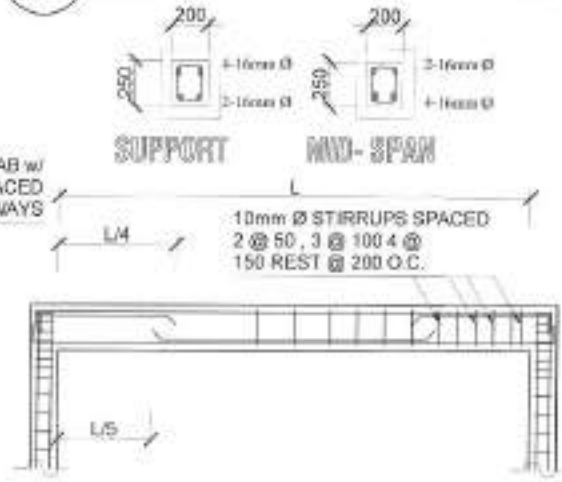

4 BEAM DET.
SCALE 1:20

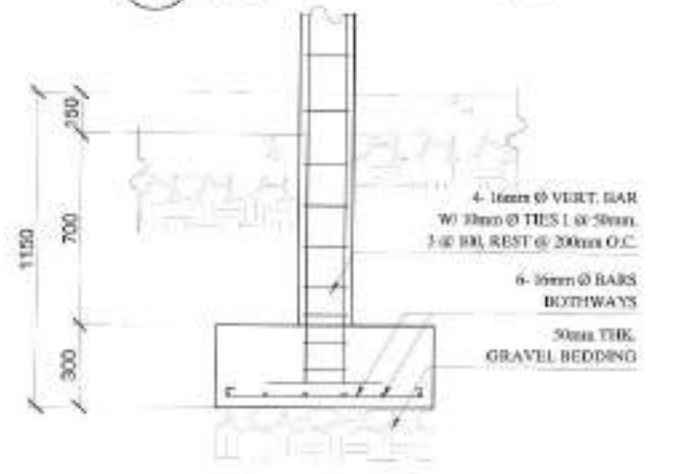

6 SECTION
SCALE 1:20

PREPARED BY: 	RECOMMENDING APPROVAL: Arch. NANCY G. ESGUERRA CITY GOVT. DEPARTMENT HEAD	APPROVED BY: Hon. MA. JOSEFINA G. BELMONTE CITY MAYOR	PROJECT TITLE: PROPOSED IMPROVEMENT OF TANDANG SORA SHRINE @ BANLAT RD. BAYAN: PROF. TANDANG SORA DIST. & JURISDICTION:	SHEET CONTENT: UTILITY ROOM FOUNDATION PLAN ROOF FRAMING PLAN WALL FOOTING DET. BEAM DETAIL COLUMN/COLUMN FOOTING DET. (C1-F1)	NOTED BY: M.S.T. DATE: 11/15/14 CHECKED BY: [Signature] DATE: 11/5/14 CADDED BY: [Signature] DATE: 11/5/14	SHEET NO.:
------------------	---	---	--	--	---	----------------

1
20

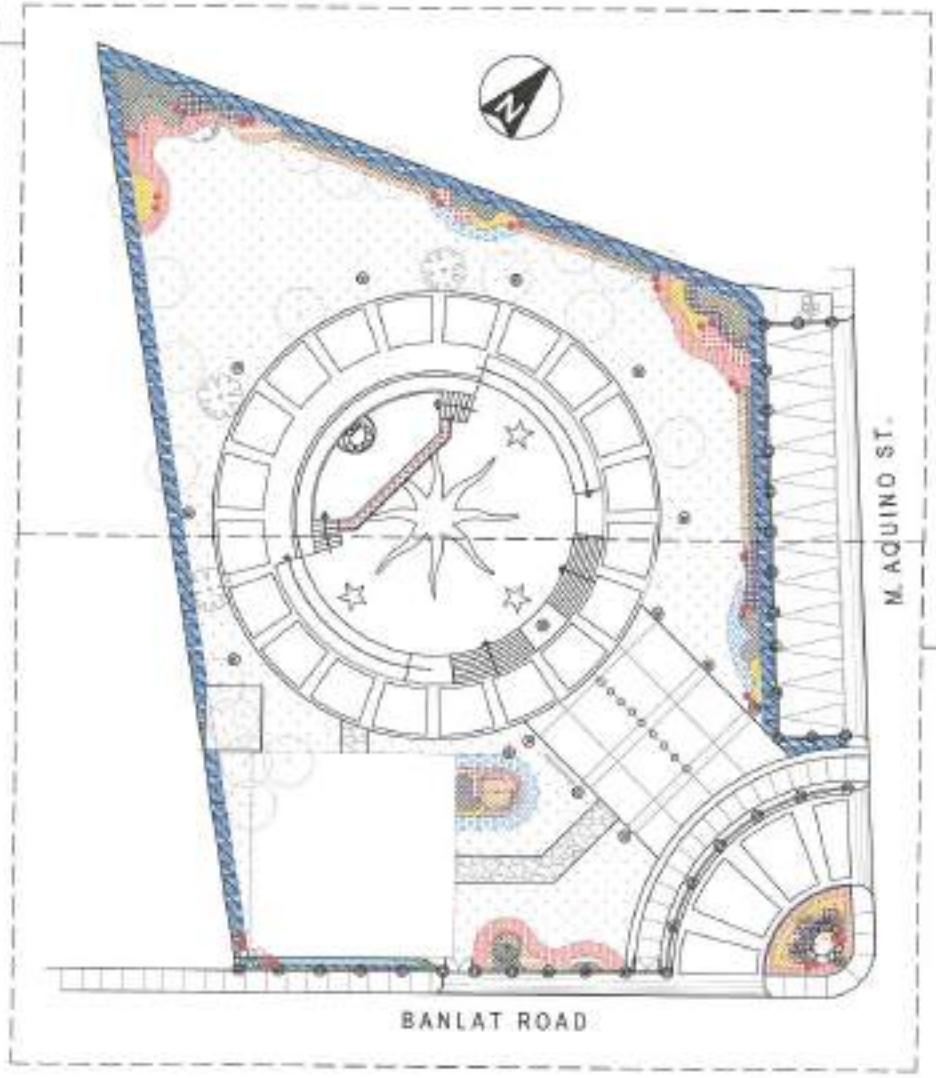





1
21

1
19

LANDSCAPE DEVELOPMENT PLAN

SCALE

1:400

PREPARED BY:	RECOMMENDING APPROVAL:	APPROVED BY:	PROJECT TITLE:	SHEET CONTENT:	NOTED BY: M.S.T.	SHEET NO.:
 PARKS DEVELOPMENT & ADMINISTRATION DEPARTMENT	 Arch. NANCY G. ESCUERRA <small>CITY GOVT. DEPARTMENT HEAD II</small>	 Hon. MA. JOSEFINA G. BELMONTE <small>CITY GOVT. DEPARTMENT HEAD II</small>	PROPOSED IMPROVEMENT OF TANDANG SORA SHRINE @ BANLAT RD. <small>PROJECT: TANDANG SORA SHRINE @ BANLAT RD.</small>	LANDSCAPE DEVELOPMENT PLAN	DATE: <i>10/15/14</i> CHECKED BY: <i>[Signature]</i> DATE: <i>10/15/14</i> CADD BY: <i>[Signature]</i> DATE: <i>10/15/14</i>	

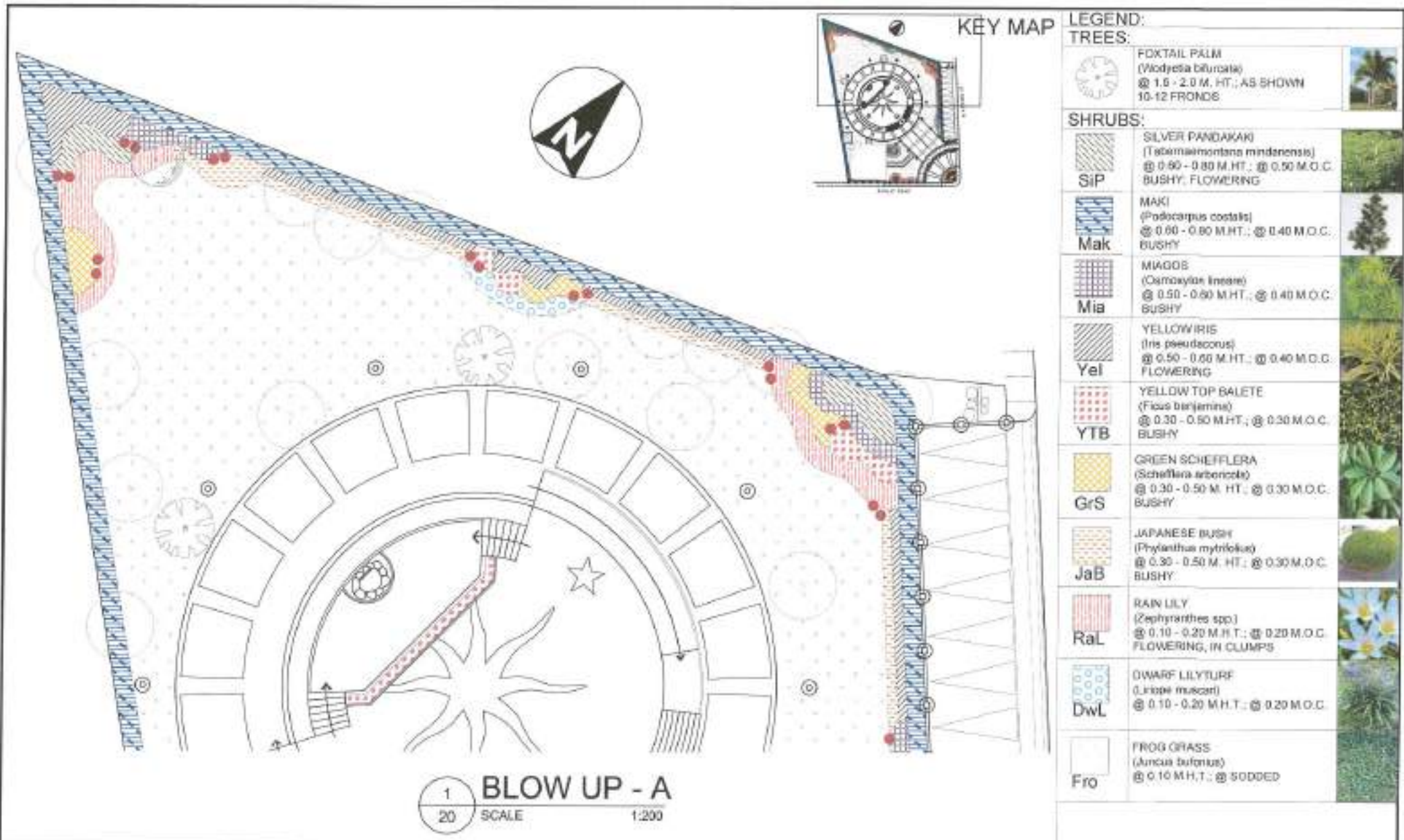

LEGEND:	
TREES:	
	FOXTAIL PALM (Wodyetia bifurcata) @ 1.0 - 2.0 M. HT.; AS SHOWN 10-12 FRONDS
SHRUBS:	
	SILVER PANDAKAK (Tabernaemontana mindanensis) @ 0.90 - 0.80 M. HT.; @ 0.50 M.O.C. BUSHY, FLOWERING
	MAK (Podocarpus costalis) @ 0.60 - 0.80 M.HT.; @ 0.40 M.O.C. BUSHY
	MIGOS (Cassipouira lineata) @ 0.50 - 0.80 M.HT.; @ 0.40 M.O.C. BUSHY
	YELLOW IRIS (Iris pseudacorus) @ 0.50 - 0.60 M.HT.; @ 0.40 M.O.C. FLOWERING
	YELLOW TOP BALETE (Ficus benjamina) @ 0.30 - 0.50 M.HT.; @ 0.30 M.O.C. BUSHY
	GREEN SCHEFFLERA (Schefflera arboricola) @ 0.30 - 0.50 M. HT.; @ 0.30 M.O.C. BUSHY
	JAPANESE BUSH (Phytanthea myrioloba) @ 0.30 - 0.50 M. HT.; @ 0.30 M.O.C. BUSHY
	RAIN LILY (Zephyranthes spp.) @ 0.10 - 0.20 M.H.T.; @ 0.20 M.O.C. FLOWERING, IN CLUMPS
	DWARF LILYTURF (Liriope muscari) @ 0.10 - 0.20 M.H.T.; @ 0.20 M.O.C.
	FROG GRASS (Ancistrum bulbosum) @ 0.10 M.H.T.; @ 500DED

1 BLOW UP - A
20 SCALE 1:200

PREPARED BY: PARKS DEVELOPMENT & ADMINISTRATION DEPARTMENT	RECOMMENDING APPROVAL: Arch. NANCY C. ESQUIERRA CITY PLANNING DEPARTMENT HEAD	APPROVED BY: Hon. MA. JOSEFINA G. BELMONTE CITY MAYOR	PROJECT TITLE: PROPOSED IMPROVEMENT OF TANDANG SORA SHRINE @ BANLAT RD. SUBTITLE: BLDG. TANDANG SORA SHRINE @ BANLAT RD.	SHEET CONTENT: LANDSCAPING KEY PLAN BLOW UP - A	NOTED BY: M.S.T. DATE: 10/12/2014 CHECKED BY: J.M.C. DATE: 10/12/2014 CADD BY: J.M.C. DATE: 10/12/2014	SHEET NO.: 20 30
---	---	---	--	--	---	------------------------

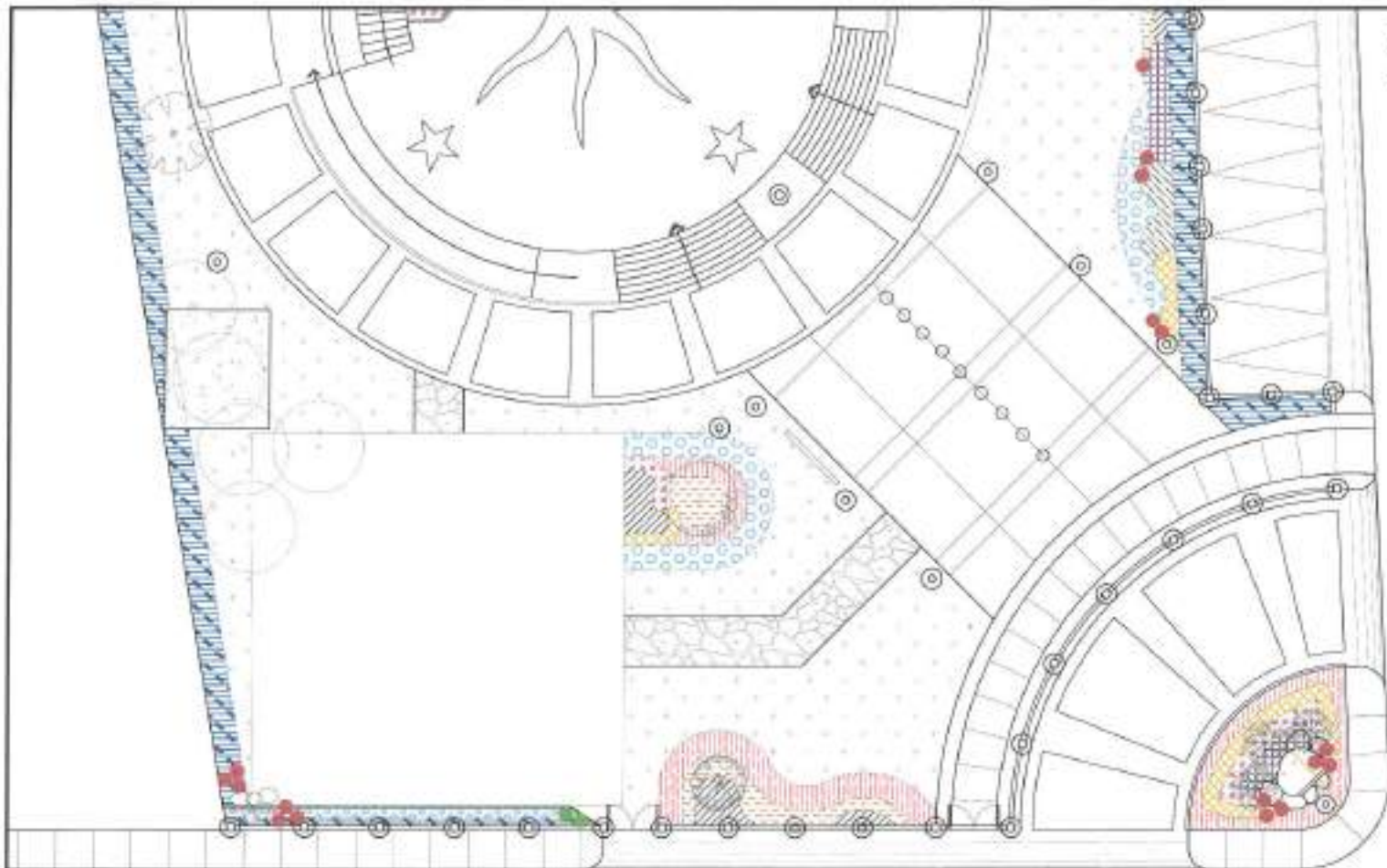

M. AQU

LEGEND:

TREES:

-  PALAWAN CHERRY
(*Cassia nodosa*)
@ 1.5 - 2.0 M. HT.; AS SHOWN
-  BOTTLE PALM
(*Hyophorbe lagenicaulis*)
@ 0.8 - 1.0 M. HT.; AS SHOWN
-  WHITE KALACHUCHI
(*Plumeria alba*)
@ 1.5 - 2.0 M. HT.; AS SHOWN

SHRUBS:

-  SILVER PANDAKAKI
(*Tabernaemontana mindanensis*)
@ 0.60 - 0.80 M.HT.; @ 0.50 M.O.C.
BUSHY; FLOWERING
-  MAKI
(*Podocarpus costalis*)
@ 0.60 - 0.80 M.HT.; @ 0.40 M.O.C.
BUSHY
-  MAGOS
(*Osmocyon lineare*)
@ 0.60 - 0.80 M.HT.; @ 0.40 M.O.C.
BUSHY
-  YELLOW IRIS
(*Iris pseudacorus*)
@ 0.60 - 0.80 M.HT.; @ 0.40 M.O.C.
FLOWERING
-  YELLOW TOP BALETE
(*Ficus benjamina*)
@ 0.30 - 0.50 M.HT.; @ 0.30 M.O.C.
BUSHY
-  GREEN SCHEFFLERA
(*Schefflera arboricola*)
@ 0.30 - 0.50 M. HT.; @ 0.30 M.O.C.
BUSHY
-  JAPANESE BUSH
(*Phytanthus myrsinifolius*)
@ 0.30 - 0.60 M. HT.; @ 0.30 M.O.C.
BUSHY
-  RAIN LILY
(*Zephyranthes* spp.)
@ 0.10 - 0.20 M.H.T.; @ 0.20 M.O.C.
FLOWERING, IN CLUMPS
-  DWARF LILYTURF
(*Liloupe muscaris*)
@ 0.10 - 0.20 M.H.T.; @ 0.20 M.O.C.



1 BLOW UP - B
21 SCALE 1:200

KEY MAP



PREPARED BY:  PARKS DEVELOPMENT & ADMINISTRATION DEPARTMENT	RECOMMENDING APPROVAL:  Aton NANCY C. ESQUERRA CITY GOVT. DEPARTMENT HEAD	APPROVED BY:  Hon. MA JOSEFINA G. BELMONTE CITY ALD. 13 CITY GOVT. DEPARTMENT HEAD	PROJECT TITLE: PROPOSED IMPROVEMENT OF TANDANG SORA SHRINE @ BANLAT RD. LOCATION: DIST. 1 (RELAND SORA DIST. 4, QUEZON CITY	SHEET CONTENT: LANDSCAPING; KEY PLAN BLOW UP - B	NOTED  M.S.T. DATE: 11/3/16/1 CHECKED BY:  DATE: CADD BY:  DATE: 8/18/14	SHEET NO.: 21 30
--	---	---	---	---	--	------------------------

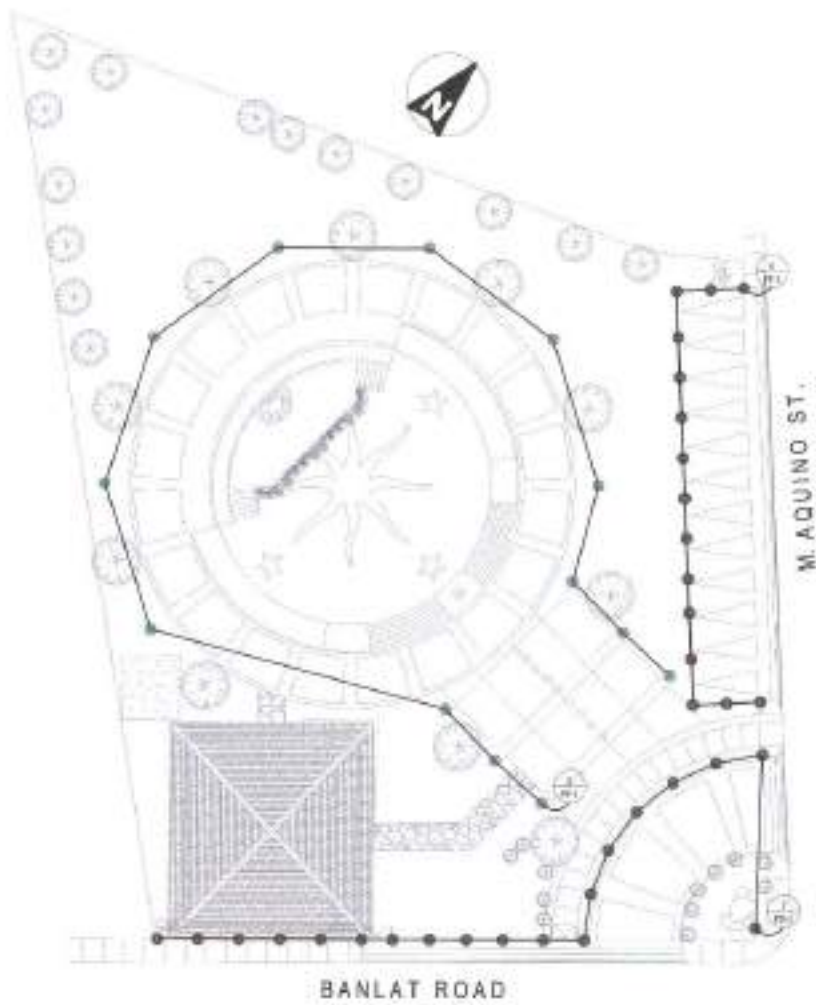

1 LIGHTING LAYOUT
 22 SCALE 1:400

- PIN LIGHT
- CASTLE TYPE WALL LAMP
- DOUBLE CASTLE TYPE PARK LAMP
- AIRCON UNIT
- CONV. OUTLET
- S1 SINGLE SWITCH
- S2 TWO GANG SWITCH
- 3WS THREE WAY SWITCH
- CIRCUIT HOMERUN
- CIRCUIT BREAKER
- GROUND
- SERVICE ENTRANCE
- PH POWER HOUSE

2 LEGEND & SYMBOLS
 22 SCALE N.T.S.

PREPARED BY: 	RECOMMENDING APPROVAL: Arch. NANCY G. ESGUERRA <small>CITY SCPT. DEPARTMENT 4043 e</small>	APPROVED BY: Hon. MA. JOSEFINA G. BELMONTE <small>CITY MAYOR</small>	PROJECT TITLE: PROPOSED IMPROVEMENT OF TANDANG SORA SHRINE @ BANLAT RD. <small>LOCATION: BRGY. TANDANG SORA DIST. 6 CUSIMON CITY</small>	SHEET CONTENT: LIGHTING LAYOUT @ SHRINE LEGEND & SYMBOLS	NOTED BY: DATE: 03/05/24 CHECKED BY: DATE: 03/05/24 CADD BY: DATE: 02/21/24	SHEET NO.: 22
------------------	--	--	---	---	--	----------------------

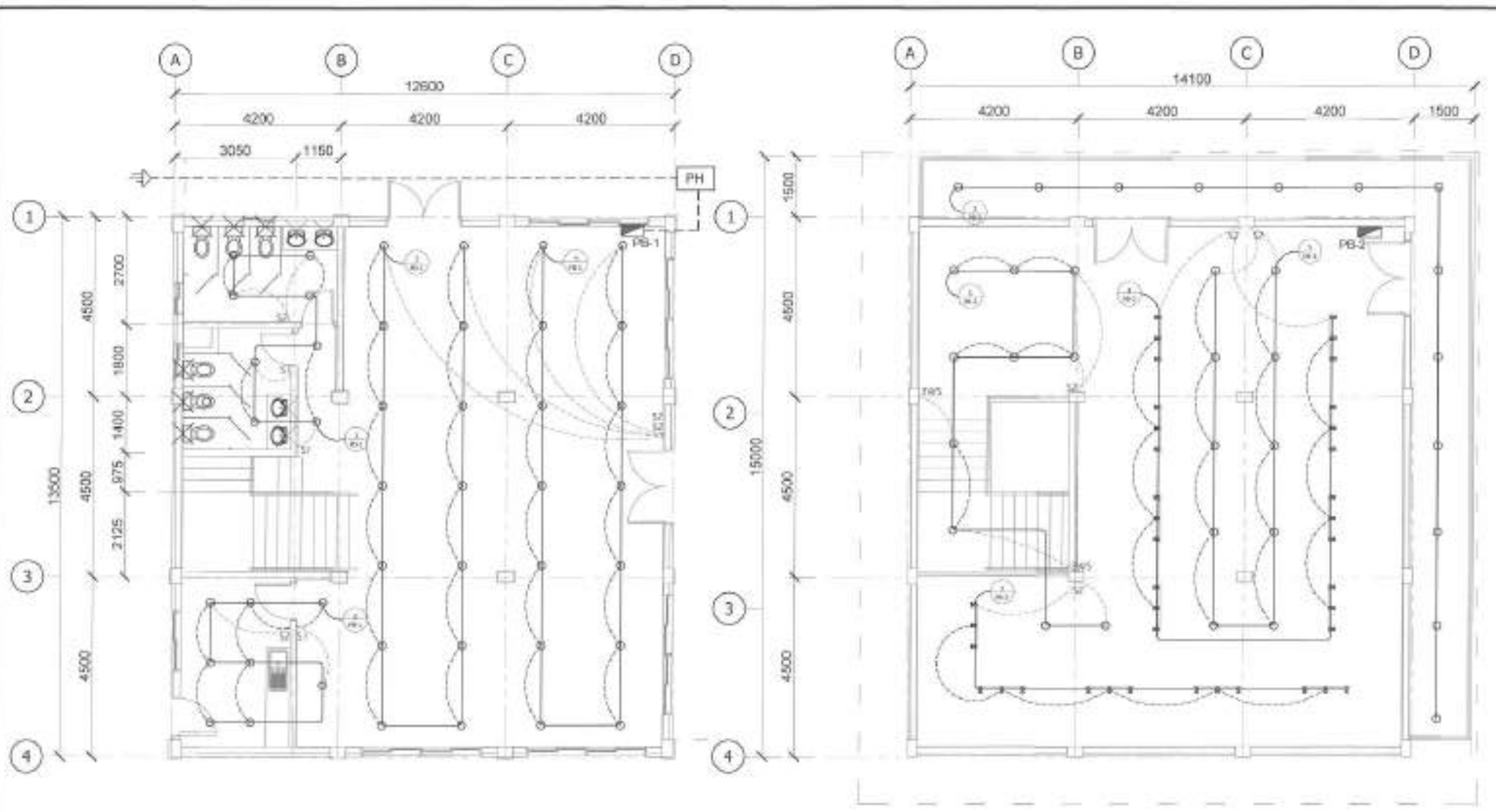

1 GROUND FLOOR LIGHTING LAYOUT
 23 SCALE 1:100

2 SECOND FLOOR LIGHTING LAYOUT
 23 SCALE 1:100



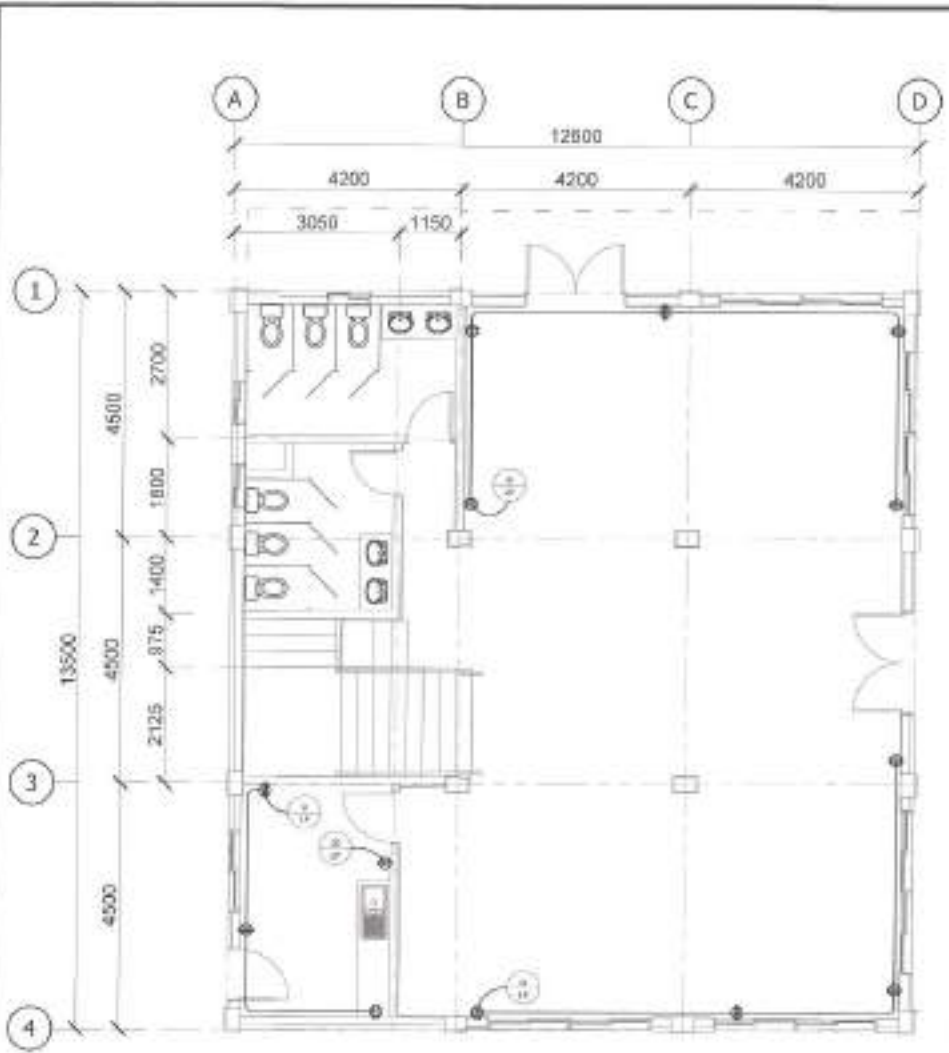

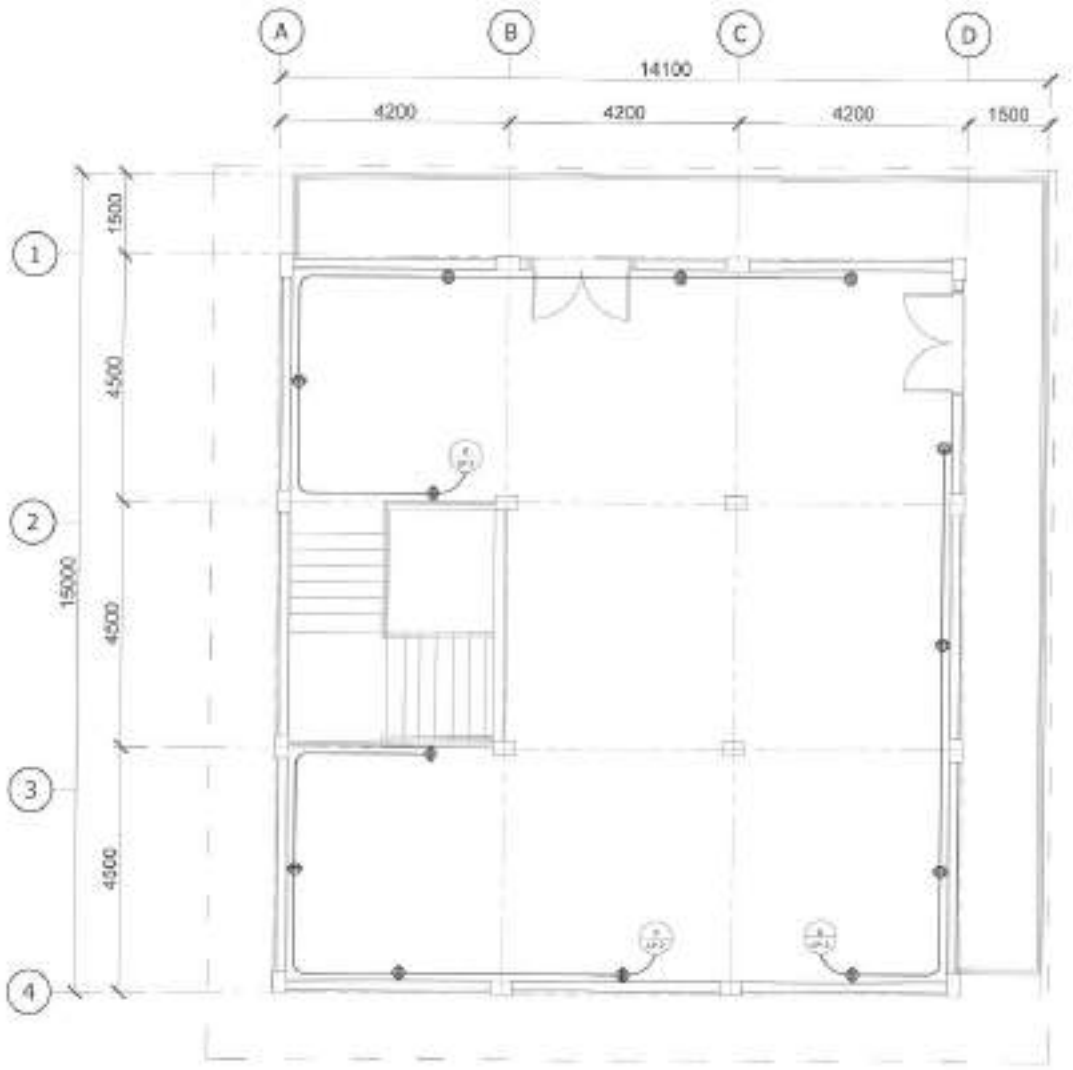

PREPARED BY: 	RECOMMENDING APPROVAL: Arch. NANCY C. ESGUERRA <small>CITY CIVIL ENGINEER REG. NO. 15208</small>	APPROVED BY: Hon. MA. JOSEFINA G. BELMONTE <small>CITY MAYOR</small>	PROJECT TITLE: PROPOSED IMPROVEMENT OF TANDANG SORA SHRINE @ BANLAT RD. <small>BOOK NO. 1875, TANDANG SORA DIST. & QUEZON CITY</small>	SHEET CONTENT: MULTI PURPOSE BLDG: GROUND FLOOR LIGHTING LAYOUT SECOND FLOOR LIGHTING LAYOUT	NOTED BY: DATE: 11/15/23 CHECKED BY: DATE: CADD BY: DATE: 11/15/23	SHEET NO.: 23 30
------------------	--	--	---	---	---	------------------------



1 GROUND FLOOR POWER LAYOUT
 SCALE 1:100

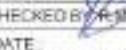
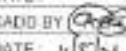

2 SECOND FLOOR POWER LAYOUT
 SCALE 1:100

PREPARED BY:	RECOMMENDING APPROVAL:	APPROVED BY:	PROJECT TITLE:	SHEET CONTENT:	NOTED BY:	SHEET NO.:
 PARKS DEVELOPMENT & ADMINISTRATION DEPARTMENT	 Arch. NANCY C. ESGUERRA <small>CITY SOUV. DEPARTMENT 4142 2</small>	 Hon. MA. JOSEFINA G. BELMONTE <small>EDUCATION</small>	PROPOSED IMPROVEMENT OF TANDANG SORA SHRINE @ BANLAT RD. <small>DESIGNER: ENYR. TANCHESORA DATE: 4/25/2024</small>	MULTI PURPOSE BLDG.: GROUND FLOOR POWER LAYOUT SECOND FLOOR POWER LAYOUT	DATE:  CHECKED BY:  DATE:  GADD BY:  DATE: 4/25/24	

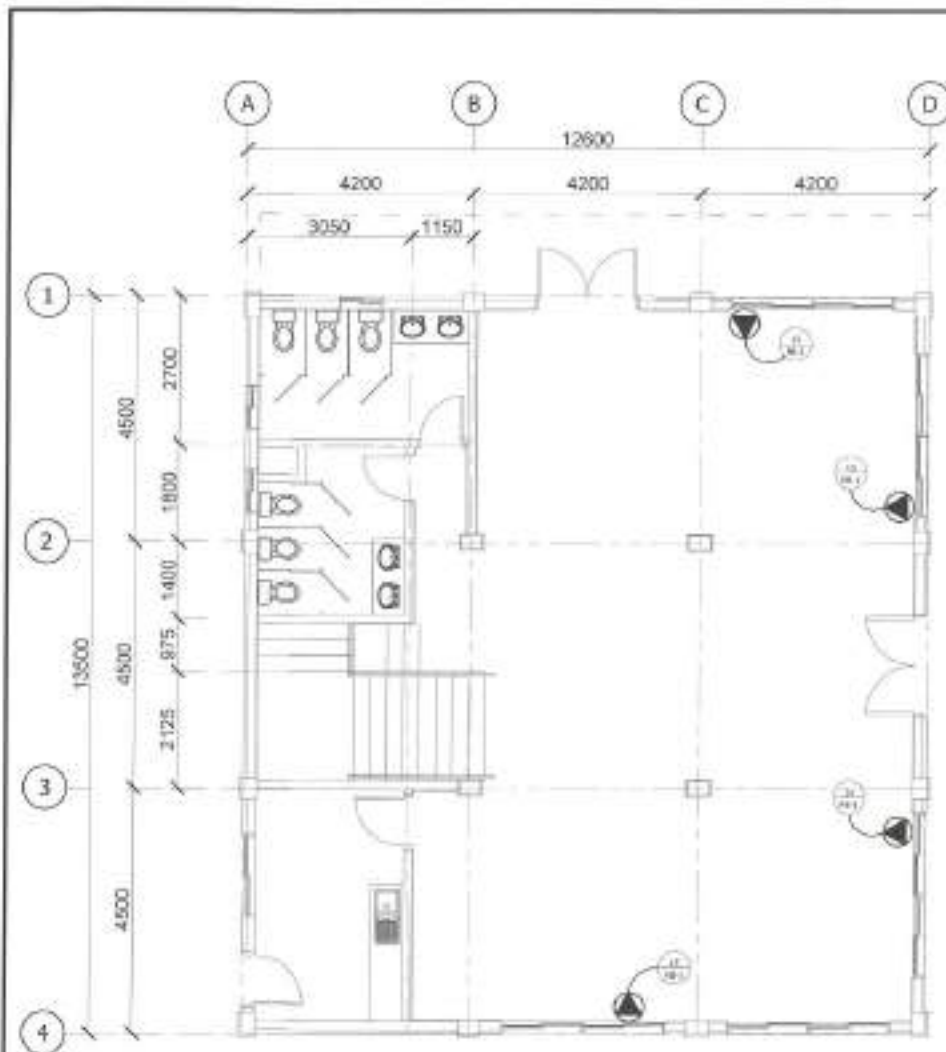

1 GROUND FLOOR ACU LAYOUT
25 SCALE 1:100

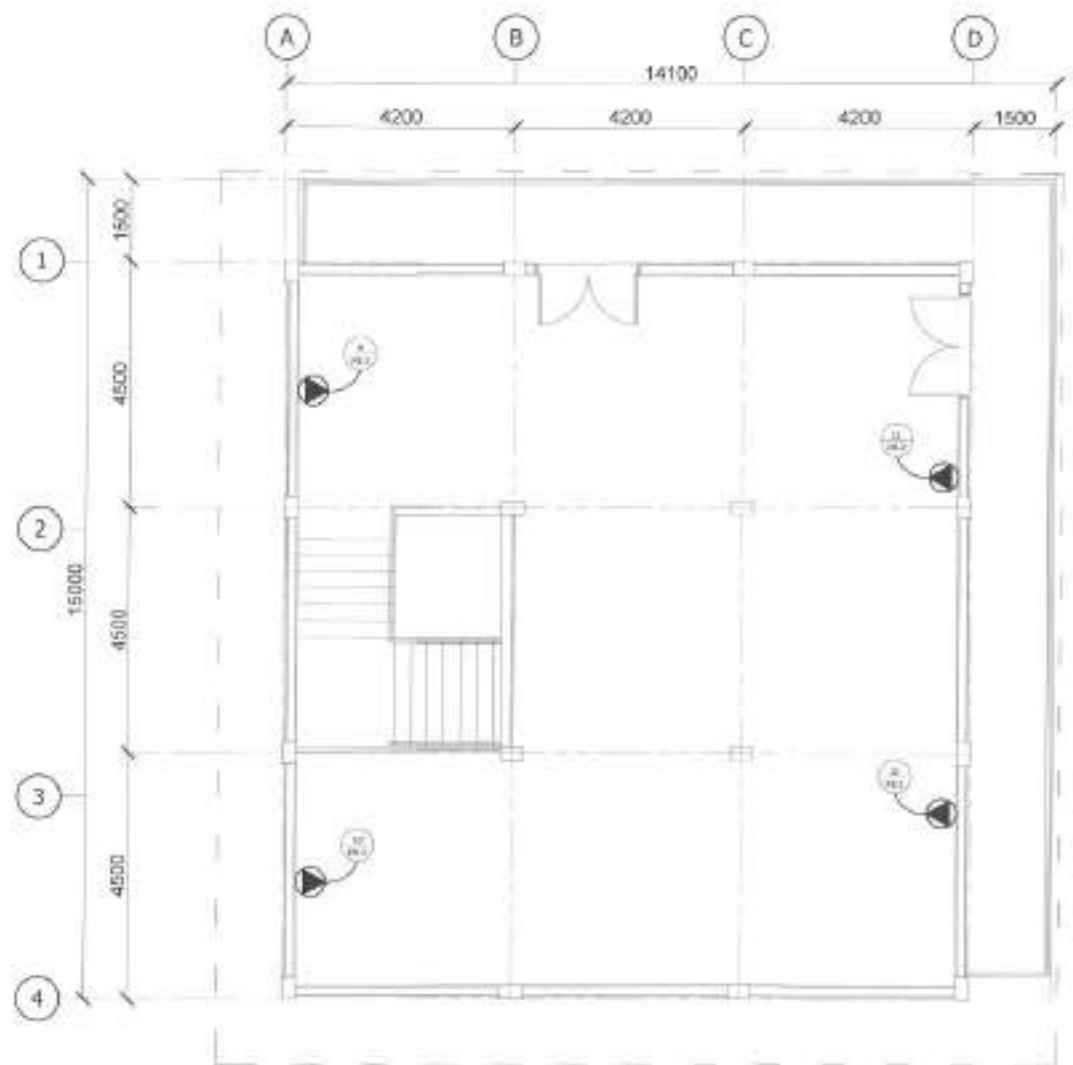

2 SECOND FLOOR ACU LAYOUT
25 SCALE 1:100

PREPARED BY	RECOMMENDING APPROVAL:	APPROVED BY:	PROJECT TITLE:	SHEET CONTENT:	NOTED BY: <i>[Signature]</i>	SHEET NO.:
 PARKS DEVELOPMENT & ADMINISTRATION DEPARTMENT	 Arch. NANCY C. ESQUERRA <small>CITY GOVT. ADMINISTRATION</small>	Hon. MA. JOSEFINA G. BELMONTTE <small>CITY MAJOR</small>	PROPOSED IMPROVEMENT OF TANDANG-SORA SHRINE @ BANLAT RD. <small>LOCATION: BPO TANDANG-SORA DET. & SUBPLOTS</small>	MULTI PURPOSE BLDG. GROUND FLOOR ACU LAYOUT SECOND FLOOR ACU LAYOUT	DATE: <i>[Date]</i> CHECKED BY: <i>[Signature]</i> DATE: <i>[Date]</i> CADD BY: <i>[Signature]</i> DATE: <i>[Date]</i>	<div style="border: 1px solid black; border-radius: 50%; width: 30px; height: 30px; display: flex; align-items: center; justify-content: center; margin: auto;"> 25 30 </div>

SCHEDULE OF LOAD (GROUND FLOOR)						
PANEL PB-1	DESCRIPTION OF LOAD	VOLT	AMPS	C.B.	WIRES	RACEWAYS
1	LIGHTING OUTLET L.O. 8-UNITS	230	4.0	20	2 # 3.5 mm ² THHN	15 mm PVC
2	LIGHTING OUTLET L.O. 10-UNITS	230	5.0	20	2 # 3.5 mm ² THHN	15 mm PVC
3	LIGHTING OUTLET L.O. 14-UNITS	230	7.0	20	2 # 3.5 mm ² THHN	15 mm PVC
4	LIGHTING OUTLET L.O. 14-UNITS	230	7.0	20	2 # 3.5 mm ² THHN	15 mm PVC
5	LIGHTING OUTLET L.O. 13-UNITS	230	6.5	20	2 # 3.5 mm ² THHN	15 mm PVC
6	LIGHTING OUTLET L.O. 15-UNITS	230	7.5	20	2 # 3.5 mm ² THHN	15 mm PVC
7	LIGHTING OUTLET L.O. 19-UNITS	230	9.5	20	2 # 3.5 mm ² THHN	15 mm PVC
8	CONV. OUTLET C.O. 5-UNITS	230	8.75	20	2 # 3.5 mm ² THHN 1 # 2.0 mm ² THHN	15 mm PVC
9	CONV. OUTLET C.O. 9-UNITS	230	5.25	20	2 # 3.5 mm ² THHN 1 # 2.0 mm ² THHN	15 mm PVC
10	SPO	230	7.0	20	2 # 3.5 mm ² THHN 1 # 2.0 mm ² THHN	15 mm PVC
11	CONV. OUTLET C.O. 4-UNITS	230	7.0	20	2 # 3.5 mm ² THHN 1 # 2.0 mm ² THHN	15 mm PVC
12	ACU	1-2HP	230	30	2 # 5.5 mm ² THHN 1 # 2.0 mm ² THHN	20 mm PVC
13	ACU	1-2HP	230	30	2 # 5.5 mm ² THHN 1 # 2.0 mm ² THHN	20 mm PVC
14	ACU	1-2HP	230	30	2 # 5.5 mm ² THHN 1 # 2.0 mm ² THHN	20 mm PVC
15	ACU	1-2HP	230	30	2 # 5.5 mm ² THHN 1 # 2.0 mm ² THHN	20 mm PVC
16	S P A R E		5.0			
TOTAL			127.5 AMP			

$I_t = 127.5 \text{ AMP @ } 80\% \text{ DF}$
 $= 102 \text{ AMP}$

USE: 2 # 30 mm² THHN WIRE
 1 # 8.0 mm² THHN WIRE
 IN 32 mm RSC/PVC

USE 125 AMPS
 MAIN CIRCUIT BREAKER

SCHEDULE OF LOAD (SECOND FLOOR)						
PANEL PB-2	DESCRIPTION OF LOAD	VOLT	AMPS	C.B.	WIRES	RACEWAYS
1	LIGHTING OUTLET L.O. 10-UNITS	230	5.0	20	2.0 mm ² THHN	15 mm PVC
2	LIGHTING OUTLET L.O. 13-UNITS	230	6.5	20	2.0 mm ² THHN	15 mm PVC
3	LIGHTING OUTLET L.O. 8-UNITS	230	2.5	20	2.0 mm ² THHN	15 mm PVC
4	LIGHTING OUTLET L.O. 8-UNITS	230	4.0	20	2.0 mm ² THHN	15 mm PVC
5	LIGHTING OUTLET L.O. 10-UNITS	230	5.0	20	2.0 mm ² THHN	15 mm PVC
6	CONV. OUTLET C.O. 5-UNITS	230	6.75	20	2 # 3.5 mm ² THHN 1 # 2.0 mm ² THHN	15 mm PVC
7	CONV. OUTLET C.O. 4-UNITS	230	7.0	20	2 # 3.5 mm ² THHN 1 # 2.0 mm ² THHN	15 mm PVC
8	CONV. OUTLET C.O. 4-UNITS	230	7.0	20	2 # 3.5 mm ² THHN 1 # 2.0 mm ² THHN	15 mm PVC
9	ACU	1-2HP	230	30	2 # 5.5 mm ² THHN 1 # 2.0 mm ² THHN	20 mm PVC
10	ACU	1-2HP	230	30	2 # 5.5 mm ² THHN 1 # 2.0 mm ² THHN	20 mm PVC
11	ACU	1-2HP	230	30	2 # 5.5 mm ² THHN 1 # 2.0 mm ² THHN	20 mm PVC
12	ACU	1-2HP	230	30	2 # 5.5 mm ² THHN 1 # 2.0 mm ² THHN	20 mm PVC
13	S P A R E		5.0			
14	S P A R E		5.0			
TOTAL			103.75 AMP			

$I_t = 103.75 \text{ AMP @ } 80\% \text{ DF}$
 $= 83 \text{ AMP}$

USE: 2 # 22 mm² THHN WIRE
 1 # 8.0 mm² THHN WIRE
 IN 25 mm RSC/PVC

USE 125 AMPS
 MAIN CIRCUIT BREAKER

MDP

$I_t = \text{PB-1} + \text{PB-2}$
 $= 127.5 + 103.75$
 $= 231.25 \text{ AMP @ } 80\% \text{ DF}$
 $= 185 \text{ AMP}$

USE: 2 # 80 mm² THHN WIRE
 1 # 14 mm² THHN WIRE
 IN 50 mm RSC/PVC

USE 200 AMPS
 MAIN CIRCUIT BREAKER

1 SCHEDULE OF LOADS

26 SCALE N.T.S.

PREPARED BY:	RECOMMENDING APPROVAL:	APPROVED BY:	PROJECT TITLE:	SHEET CONTENT:	NOTED BY:	SHEET NO.:
	 Arch. NANCY C. ESGUERRA <small>CITY GOVT. ENGINEER/ARCHT.</small>	 Hon. MA. JOSEFINA G. BELMONTE <small>CITY MAJOR</small>	PROPOSED IMPROVEMENT OF TANDANG SORA SHRINE @ BANLAT RD. <small>LOCALITY: SORA, TANDANG SORA DIST. QUEZON CITY</small>	SCHEDULE OF LOADS	 DATE:  CHECKED BY:  DATE:  CADD BY:  DATE: 	

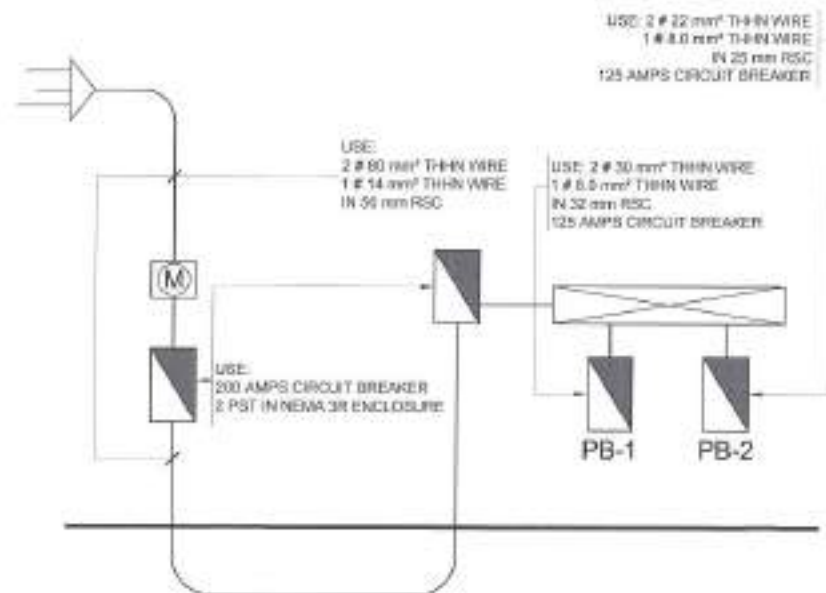
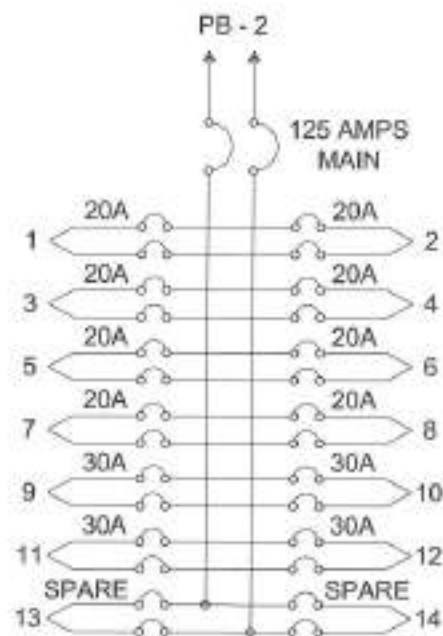
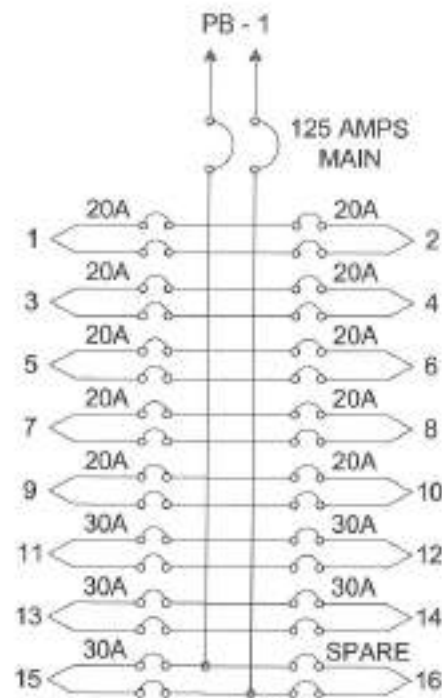

1
27 SCALE N.T.S. **DETAIL OF PANEL**

2
27 SCALE N.T.S. **RISER DIAGRAM**

PREPARED BY:	RECOMMENDING APPROVAL:	APPROVED BY:	PROJECT TITLE:	SHEET CONTENT:	NOTED BY (M.S.):	SHEET NO.:
	 Arch. NANCY G. ESGUERRA <small>CITY GOV. COMMITTEE HEAD II</small>	 Hon. MA. JOSEFINA G. BELMONTE <small>CITY MGR. QUEZON CITY</small>	PROPOSED IMPROVEMENT OF TANDANG SORA SHRINE @ BANLAT RD. <small>LOCALITY: BGY. TANDANG SORA DIST. 8 - QUEZON CITY</small>	RISER DIAGRAM DETAIL OF PANEL	DATE: CHECKED BY: DATE: CADD BY: DATE:	 27 30

- 1) ALL ELECTRICAL WORKS SHALL BE DONE IN ACCORDANCE WITH THE PROVISIONS OF THE LATEST EDITION OF THE PHILIPPINE ELECTRICAL CODE EXISTING LOCAL ORDINANCES AND REQUIREMENTS OF THE LOCAL POWER UTILITY AND STANDARDS.
- 2) TYPE OF POWER SERVICE SHALL BE DONE SINGLE PHASE, 3 WIRE, 230V, 60HZ.
- 3) WIRING METHOD SHALL BE DONE IN RIGID PVC CONDUIT RUN EMBEDDED IN CONCRETE SLABS, WALLS, COLUMNS, BETWEEN PARTITIONS AND INSIDE CEILING SPACES. SURFACE MOULDING WIRING MAY BE USED.
- 4) UNLESS OTHERWISE INDICATED IN THE PLAN, THE MINIMUM SIZE OF WIRE AND CONDUIT TO BE USED SHALL BE WIRED 3.5mm² IN SIZE AND 15mm ϕ PVC RESPECTIVELY FOR CIRCUIT HOMERUNS.
- 5) WHEREEVER REQUIRED AND NECESSARY, PULL BOXES AND JUNCTION BOXES OF PROPER SIZES SHALL BE INSTALLED AT CONVENIENT AND IN CONSPICUOUS LOCATION ALTHOUGH SUCH BOXES ARE NOT SHOWN ON THE PLANS NOR MENTIONED IN THE SPECIFICATIONS.
- 6) ALL NON- CURRENT CARRYING METAL PARTS OF THE EQUIPMENT SHALL BE PROPERLY GROUNDED.
- 7) ALL MATERIALS TO BE USED SHALL BE NEW AND OF APPROVED TYPE FOR THE LOCATION AND PURPOSE.
- 8) STANDARD TYPES OF ACCESSORIES SPLICING DEVICES, TERMINATION AND OTHER APPURTENANCES FOR THE ELECTRICAL INSTALLATION SHALL BE USED.
- 9) ALL ELECTRICAL WORKS SHALL BE DONE UNDER THE DIRECT SUPERVISION OF A REGISTERED ELECTRICAL ENGINEER (REE) OR REGISTERED MASTER ELECTRICIAN (RME)



1 GENERAL NOTES
28 SCALE N.T.S.

2 LOCATION MAP
28 SCALE N.T.S.

PREPARED BY	RECOMMENDING APPROVAL	APPROVED BY	PROJECT TITLE	SHEET CONTENT	NOTED BY	SHEET NO.
 PARKS DEVELOPMENT & ADMINISTRATION DEPARTMENT	 Arch. NANCY C. ESQUERRA <small>CITY PLANNING & DEVELOPMENT OFFICER</small>	 Hon. MA. JOSEFINA G. BELMONTE <small>CITY MAYOR</small>	PROPOSED IMPROVEMENT OF TANDANG SORA SHRINE @ BANLAT RD. <small>LOCATION: WEST TANDANG SORA ST. @ BANLAT RD.</small>	GENERAL NOTES VICINITY MAP	 NOTED BY: [Signature] DATE: [Signature] CHECKED BY: [Signature] DATE: [Signature] CADD BY: [Signature] DATE: [Signature]	<div style="border: 1px solid black; border-radius: 50%; width: 30px; height: 30px; display: flex; align-items: center; justify-content: center;"> 28 30 </div>

TAP TO NEAREST UTILITY ROOM

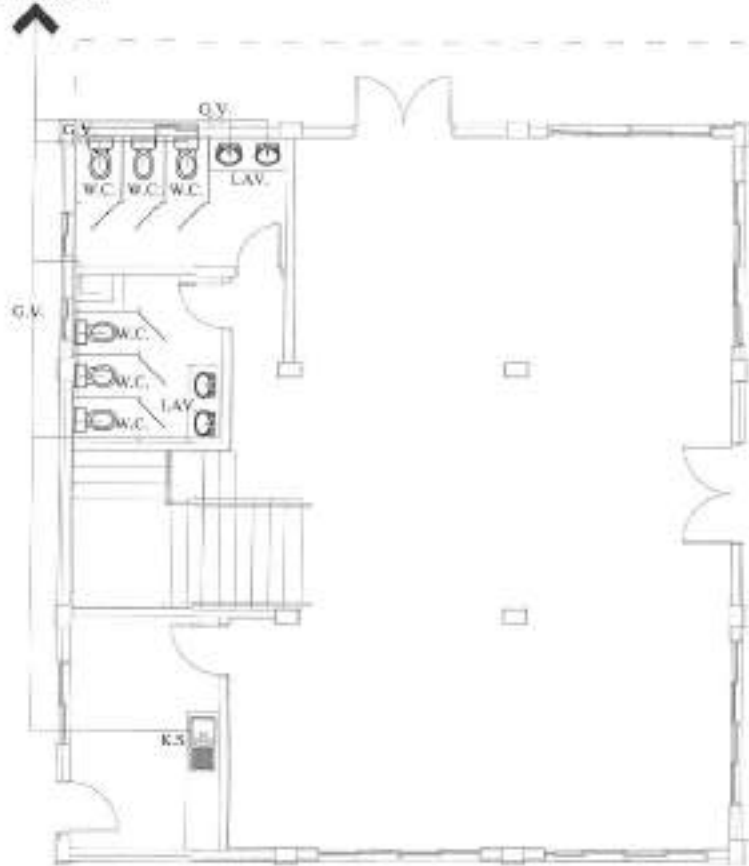

1
29 SCALE 1:100
GROUND FLOOR WATERLINE LAYOUT

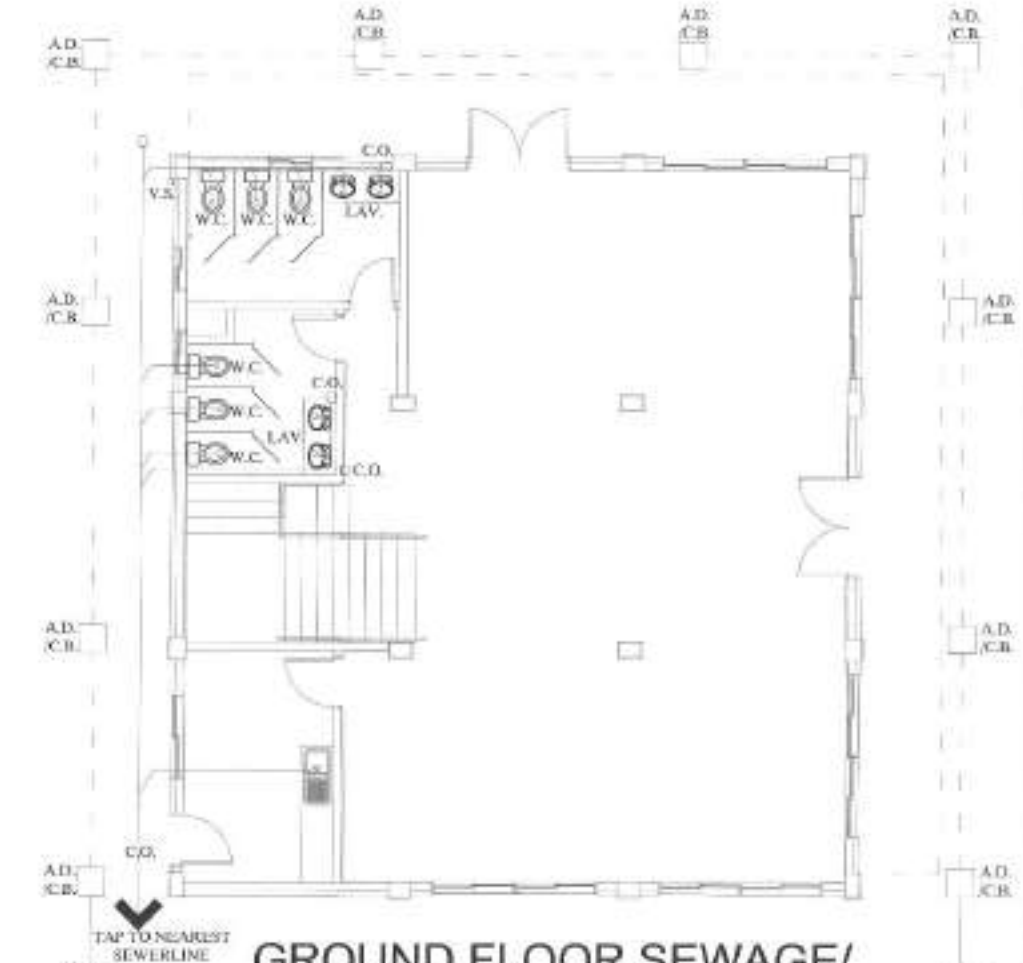

2
29 SCALE 1:100
GROUND FLOOR SEWAGE/STORM DRAINAGE LAYOUT

<p>PREPARED BY</p>	<p>RECOMMENDING APPROVAL:</p> <p>Arch. NANCY G. ESGUERRA CITY GOVT. REPRESENTATIVE</p>	<p>APPROVED BY:</p> <p>Hon. MA JOSEFINA G. BELMONTE CITY MAYOR</p>	<p>PROJECT TITLE:</p> <p>PROPOSED IMPROVEMENT OF TANDANG SORA SHRINE @ BANLAT RD.</p> <p>LOCATION: BRG. TANDANG SORA, DIST. N. QUEZON CITY</p>	<p>SHEET CONTENT:</p> <p>MULTI PURPOSE BLDG. GROUND FLOOR WATERLINE LAYOUT GROUND FLOOR SEWAGE/STORM DRAINAGE LAYOUT</p>	<p>NOTES: M.S.T. DATE: 11/20/24 CHECKED BY: [Signature] DATE: 11/21/24 CADD BY: [Signature] DATE: 11/21/24</p>	<p>SHEET NO. 29/30</p>
--------------------	--	--	--	--	--	------------------------

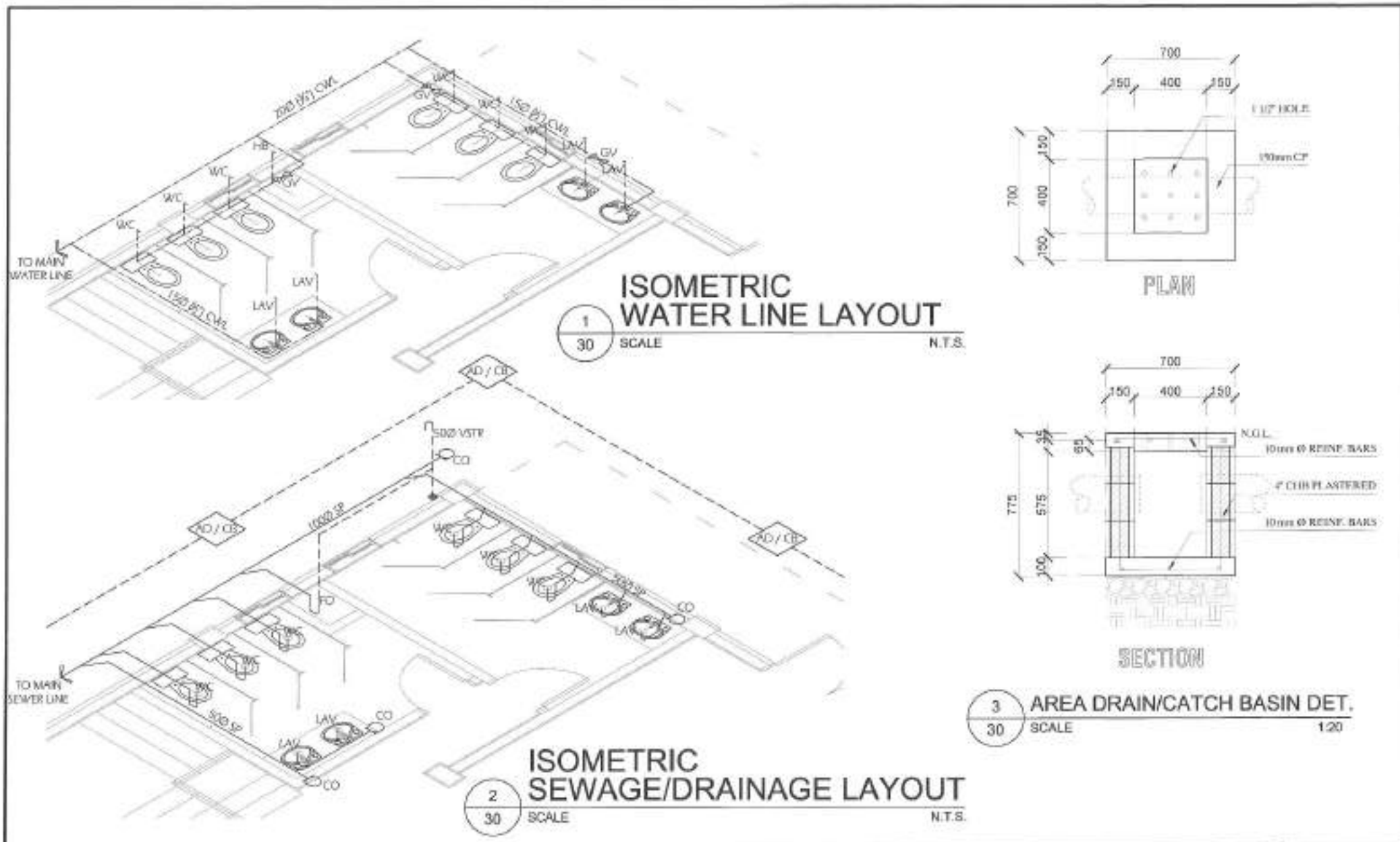

PREPARED BY: 	RECOMMENDING APPROVAL: Arch. NANCY C. ESGUERRA CITY GOVT. DEPARTMENT HGA II	APPROVED BY: Hon. MA. JOSEFINA G. BELMONTE CITY GOVT. DEPARTMENT HGA II	PROJECT TITLE: PROPOSED IMPROVEMENT OF TANDANG SORA SHRINE @ BANLAT RD. <small>DESIGNER: GREY, TANDANG SORA DIST. 4 QUEZON CITY</small>	SHEET CONTENT: MULTI-PURPOSE BLDG. ISOMETRIC WATER LINE LAYOUT SEWAGE/ DRAINAGE LAYOUT AREA DRAIN/ CATCH BASIN DET.	NOTED BY: M.S.T. DATE: 11/5/2021 CHECKED BY: DATE: 11/5/21 CADD BY: DATE: 11/5/21	SHEET NO.: 30
------------------	---	---	--	--	--	----------------------

Section VIII. Bill of Quantities

Notes on the Bill of Quantities

Objectives

The objectives of the Bill of Quantities are:

- a. to provide sufficient information on the quantities of Works to be performed to enable Bids to be prepared efficiently and accurately; and
- b. when a Contract has been entered into, to provide a priced Bill of Quantities for use in the periodic valuation of Works executed.

In order to attain these objectives, Works should be itemized in the Bill of Quantities in sufficient detail to distinguish between the different classes of Works, or between Works of the same nature carried out in different locations or in other circumstances which may give rise to different considerations of cost. Consistent with these requirements, the layout and content of the Bill of Quantities should be as simple and brief as possible.

Daywork Schedule

A Daywork Schedule should be included only if the probability of unforeseen work, outside the items included in the Bill of Quantities, is high. To facilitate checking by the Entity of the realism of rates quoted by the Bidders, the Daywork Schedule should normally comprise the following:

- a. A list of the various classes of labor, materials, and Constructional Plant for which basic daywork rates or prices are to be inserted by the Bidder, together with a statement of the conditions under which the Contractor will be paid for work executed on a daywork basis.
- b. Nominal quantities for each item of Daywork, to be priced by each Bidder at Daywork rates as Bid. The rate to be entered by the Bidder against each basic Daywork item should include the Contractor's profit, overheads, supervision, and other charges.

Provisional Sums

A general provision for physical contingencies (quantity overruns) may be made by including a provisional sum in the Summary Bill of Quantities. Similarly, a contingency allowance for possible price increases should be provided as a provisional sum in the Summary Bill of Quantities. The inclusion of such provisional sums often facilitates budgetary approval by avoiding the need to request periodic supplementary approvals as the future need arises. Where such provisional sums or contingency allowances are used, the SCC should state the manner in which they will be used, and under whose authority (usually the Procuring Entity's Representative's).

The estimated cost of specialized work to be carried out, or of special goods to be supplied, by other contractors should be indicated in the relevant part of the Bill of Quantities as a particular provisional sum with an appropriate brief description. A separate procurement procedure is normally carried out by the Procuring Entity to select such specialized contractors. To provide an element of competition among the Bidders in respect of any facilities, amenities, attendance, etc., to be provided by the successful Bidder as prime Contractor for the use and convenience of the specialist contractors, each related provisional sum should be followed by an item in the Bill of Quantities inviting the Bidder to quote a sum for such amenities, facilities, attendance, etc.

Signature Box

A signature box shall be added at the bottom of each page of the Bill of Quantities where the authorized representative of the Bidder shall affix his signature. Failure of the authorized representative to sign each and every page of the Bill of Quantities shall be a cause for rejection of his bid.

These Notes for Preparing a Bill of Quantities are intended only as information for the Procuring Entity or the person drafting the Bidding Documents. They should not be included in the final documents.

PROJECT TITLE : PROPOSED IMPROVEMENT OF TANDANG SORA SHRINE AT BANLAT ROAD

LOCATION : BARANGAY TANDANG SORA, DISTRICT 6, QUEZON CITY

PROJECT NO. : 22 - 00053

DURATION : Three Hundred (300) Calendar Days

BREAKDOWN OF COST

NO.	ITEM OF WORK / DESCRIPTION	MATERIALS COST	LABOR COST	INDIRECT COST	AGGREGATE COST
1.00	General Requirements				
2.00	Rehabilitation of Tandang Sora Sculpture				
3.00	Rehabilitation of existing perimeter fence				
4.00	Rehabilitation of existing pavement				
5.00	Construction of two storey multi-purpose building				
6.00	Construction of utility room				
7.00	Electrical works				
8.00	Landscaping works				
9.00	Electrica Tapping				
	TOTAL				

TOTAL COST P

LUMP SUM BID IN WORDS : _____

Contractor : _____

BILL OF QUANTITIES
(Parks Improvement / Rehabilitation Project)

PROJECT TITLE : PROPOSED IMPROVEMENT OF TANDANG SORA SHRINE AT BANLAT ROAD

LOCATION : BARANGAY TANDANG SORA, DISTRICT 6, QUEZON CITY

PROJECT NO. : 22 - 00053

DURATION : Three Hundred (300) Calendar Days

SCOPE OF WORK :

- 1.00 General Requirements
- 2.00 Rehabilitation of Tandang Sora Sculpture
- 3.00 Rehabilitation of existing perimeter fence
- 4.00 Rehabilitation of existing pavement
- 5.00 Construction of two storey multi-purpose building
- 6.00 Construction of utility room
- 7.00 Electrical works
- 8.00 Landscaping works

ITEM NO.	WORK DESCRIPTION AND SCOPE OF WORK	UNIT	QTY	UNIT COST	MATERIAL COST	LABOR COST	TOTAL COST
1.00	General Requirements						
	Temporary enclosure	unit	1				
	Temporary office and warehouse	unit	1				
	Temporary lighting and water facilities	days	300				
	Billboard	unit	1				
	Sub-total # 1.00						
2.00	Rehabilitation of Tandang Sora Sculpture						
	(including wall sculptures)	unit	1				
	Granite tiles	sq.m	100				
	Sub-total # 2.00						
3.00	Rehabilitation of existing perimeter fence						
	Repair of dilapidated araal tiles	sq.m	130				
	Repair of dilapidated steel fence	sq.m	96				
	Sealer	sq.m	260				
	Painting (metal surface)	sq.m	191				
	Painting (latex primer)	sq.m	275				
	Painting (concrete surface)	sq.m	275				
	Sub-total # 3.00						
4.00	Rehabilitation of existing pavement						

ITEM NO.	WORK DESCRIPTION AND SCOPE OF WORK	UNIT	QTY	UNIT COST	MATERIAL COST	LABOR COST	TOTAL COST
	Removal of existing turfgrass pavers	sq.m	471				
	Removal of existing stamped pavement	sq.m	93				
	Hauling of removed pavement	sq.m	564				
	Cleaning of existing pavement	sq.m	1455				
	Repair of existing pavement	sq.m	1455				

ITEM NO.	WORK DESCRIPTION AND SCOPE OF WORK	UNIT	QTY	UNIT COST	MATERIAL COST	LABOR COST	TOTAL COST
	Concrete	cu.m	5				
	Rebars w/ tie wire	kgs	139				
	Stamped concrete	sq.m	45				
	Epoxy primer	sq.m	1455				
	Rubberized floor coating	sq.m	1455				
	Sub-total # 4.00						
5.00	Construction of two storey multi-purpose building						
	5.10 Earthworks						
	Excavation	cu.m	39				
	Backfill & compaction	cu.m	24				
	Earthfill	cu.m	109				
	Demolition of existing building	units	1				
	5.20 Concrete Works						
	Concrete	cu.m	109				
	Footing	cu.m	8				
	Column	cu.m	17				
	Tie beams/wall footing	cu.m	9				
	Slab on grade	cu.m	18				
	Beams	cu.m	25				
	Suspended slab	cu.m	23				
	Roof beams	cu.m	9				
	Rebars w/ tie wire	kgs	15643				
	Footing	kgs	467				
	Column	kgs	4534				
	Tie beams	kgs	1748				
	Slab on grade	kgs	573				
	Beams	kgs	4282				
	Suspended slab	kgs	2291				
	Roof beams	kgs	1748				
	Forms	sq.m	1016				
	Column	sq.m	226				
	Tie beams	sq.m	104				
	Beams	sq.m	215				
	Roof beams	sq.m	115				
	Suspended slab	sq.m	178				
	Slab on grade	sq.m	178				
	Coco lumber	bd,ft	16830				
	5.30 Masonry works						
	CHB # 6 w/ reinforcement	sq.m	364				
	CHB # 4 w/ reinforcement	sq.m	107				
	Concrete balluster	pcs	134				

ITEM NO.	WORK DESCRIPTION AND SCOPE OF WORK	UNIT	QTY	UNIT COST	MATERIAL COST	LABOR COST	TOTAL COST
	Concrete moulding	lm	432				
	Plastering	sq.m	848				
	- Floor and wall finish						
	.60 x .60m granite floor tiles	sq.m	145				
	.60 x .60m ceramic floor tiles	sq.m	174				
	.30 x .30m floor tiles	sq.m	65				
	.30 x .30m wall tiles	sq.m	85				
	Floor topping (50mm thk)	sq.m	384				
	PVC Panel on light metal frame	sq.m	94				
	Glass blocks	pcs	10				
	Wooden baseboard	lm	105				
	KILN Dried wood planks	bd.ft	268				
	Wooden baluster	pcs	32				
	Wooden handrail	bd.ft	34				
	Wood preservative clear	sq.m	95				
	Sanding Sealer	sq.m	53				
	Wood stain	sq.m	53				
	Machine cut araal stone	sq.m	335				
	Sealer	sq.m	335				
	5.40 Ceiling Works						
	Ficem board on 0.40 x 0.60m metal frame	sqm	38				
	PVC Panel on 0.60m metal frame	sq.m	300				
	frame (Ceiling & Fascia)	sq.m	79				
	5.50 Hardware and fabricated materials						
	Aluminum sliding glass window with aluminum frame, powder coated with complete access.	sq.m	46.92				

ITEM NO.	WORK DESCRIPTION AND SCOPE OF WORK	UNIT	QTY	UNIT COST	MATERIAL COST	LABOR COST	TOTAL COST
	1.80 x 2.10 double swing metal door w/ door jamb, wood like design finish w/ complete access.(design for architect's approval)	sets	3				
	0.90 x 2.10 single swing metal door w/ door jamb, wood like design finish w/ complete access.(design for architect's approval)	sets	2				
	.80 x 2.10 wooden flush door w/ 2 x 5 door jamb, painted finish w/ complete access	sets	4				
	1.50 x 1.50 Capiz window	sets	27				
	5.60 Roofing works						
	Roof framing						
	3/16 x 2" x 2" Angle bar (4.5mm thk)	kgs	3227				
	1.5 mm thk 2 x 6 C-purlins	kgs	2212				
	3/16 x 2" Flat bar	kgs	152				
	12mm dia Sagrod	kgs	156				
	Welding rod	kgs	40				
	Grinding disk 4" diam	pcs	15				
	Cutting disk 4" diam	pcs	10				
	Cutting disk 14" diam	pcs	5				
	LPG refill	cyls	2				
	Oxygen refill	cyls	10				
	Hacksaw blade	pcs	5				
	Metal primer	sq.m	406				
	Roofing						
	mm)	sq.m	280				
	mesh	sq.m	280				
	Pre painted G.I. Ridge roll (0.50 mm)	pcs	17				
	Pre painted G.I. Flashing (0.50 mm)	pcs	10				
	Tekscrew	pcs	2529				
	5.70 Finishes						
	Surface preparation - masonry/concrete	sq.m	565				
	Latex primer	sq.m	565				
	Painting (concrete)	sq.m	565				
	Logo with metal frame backing powder	pcs	2				
	200 mm high x 50 mm thk stainless letter	pcs	26				
	5.80 Plumbing works						
	Fixtures & accessories						
	cover	sets	6				
	Lavatory w/ complete fittings	sets	4				
	Lavatory faucet (stainless or brass)	pcs	4				

ITEM NO.	WORK DESCRIPTION AND SCOPE OF WORK	UNIT	QTY	UNIT COST	MATERIAL COST	LABOR COST	TOTAL COST
	Stainless kitchen sink w/ heavy duty kitchen faucet, complete accessories and fittings	set	1				

ITEM NO.	WORK DESCRIPTION AND SCOPE OF WORK	UNIT	QTY	UNIT COST	MATERIAL COST	LABOR COST	TOTAL COST
	4" x 4" Floor drain (stainless)	pcs	6				
	Grab rail 1½ diam stainless (L-type)	set	2				
	Kitchen countertop	unit	1				
	Cubicle partition	units	6				
	Water line						
	½" diam PPR pipe	pcs	8				
	½" diam PPR coupling	pcs	5				
	½" diam PPR elbow	pcs	10				
	½" diam PPR tee	pcs	5				
	¾"Ø PPR Pipe	pcs	6				
	¾"Ø PPR Coupling	pcs	6				
	¾"Ø PPR Tee	pcs	8				
	¾"Ø PPR Elbow	pcs	10				
	½" diam PPR Adaptor	pcs	12				
	½" diam Gate valve (heavy duty)	sets	2				
	PVC solvent cement (200 cc)	can	1				
	Sewer line						
	4" PVC pipe (series 1000)	pcs	20				
	4" x 4" PVC wye	pcs	5				
	4" x 2" PVC wye	pcs	6				
	4" PVC elbow	pcs	8				
	4" x 4" PVC tee	pcs	3				
	4" PVC clean out	pcs	6				
	3" PVC pipe (series 1000)	pcs	16				
	3" PVC elbow 45°	pcs	16				
	3" PVC elbow 90°	pcs	8				
	2" PVC pipe, series 1000	pcs	5				
	2" PVC tee	pcs	2				
	2" PVC elbow	pcs	10				
	2" PVC P - trap	pcs	5				
	PVC solvent cement (400 cc)	cans	4				
	Septic tank						
	Excavation	cu.m	7				
	Concrete	cu.m	0.89				
	Rebars w/ tie wire	kgs	88				
	Formworks	sq.m	5				
	6" CHB w/ rebars	sq.m	18				
	Plastering	sq.m	27				
	4" diam PVC pipe	pc	1				
	4" diam PVC tee	pcs	3				
	4" diam PVC clean out	pcs	3				
	Solvent cement (200cc)	can	1				

ITEM NO.	WORK DESCRIPTION AND SCOPE OF WORK	UNIT	QTY	UNIT COST	MATERIAL COST	LABOR COST	TOTAL COST
	Construction of drainage canal w/ concrete cover						
	Excavation	cu.m	17				
	Concrete	cu.m	6				
	4" CHB w/ rebars, series 1000	sq.m	48				
	Rebars w/ tie wires	kgs	138				
	Formworks	sq.m	56				
	Plastering	sq.m	48				
	12" dia concrete pipe	lm	10				
	5.90 Electrical works						
	THWN 5.5mm ² stranded	roll	4				
	THWN 3.5mm ² stranded	rolls	6				
	THWN 2.0mm ² stranded	rolls	3				
	PVC Pipe 3/4" dia. w/ coupling (Orange)	pcs	35				

ITEM NO.	WORK DESCRIPTION AND SCOPE OF WORK	UNIT	QTY	UNIT COST	MATERIAL COST	LABOR COST	TOTAL COST
	PVC Pipe 1/2" dia. w/ coupling (Orange)	pcs	150				
	PVC Long Elbow 3/4"dia.	pcs	20				
	PVC Long Elbow 1/2"dia.	pcs	36				
	PVC Solvent (400 cc)	cans	2				
	Junction box 4"x4"	pcs	90				
	Utility box 4"x4"	pcs	47				
	Receptacle 4"x4"	pcs	1				
	Track light w/ railing and 3-15watts LED bulb	sets	13				
	Pinlight 5" dia w/ 9 watts LED bulb	sets	80				
	Inter-changeable convenience outlet	sets	26				
	One gang switch with plate and cover	sets	4				
	Three gang switch with plate and cover	sets	8				
	Three way switch with plate and cover	sets	2				
	light	sets	4				
	Wall mounted light with 12w LED bulb	sets	6				
	cover	sets	10				
	Aircon outlet with ground and cover	sets	8				
	type)	sets	8				
	Exhaust fan 14"	sets	1				
	Panel board: bolt-on type, 2pole, single phase, Main: 1 - 125amp circuit breaker, branches: 8 - 20amp circuit breakers , 6 - 30 amp circuit breaker	set	1				
	Panel board: bolt-on type, 2pole, single phase, Main: 1 - 125amp circuit breaker, branches: 8 - 20amp circuit breakers , 4 - 30 amp circuit breaker	set	1				
	400 CC PVC solvent cement	can	3				
	Electrical tape	pcs	8				
	Hacksaw blade	pcs	3				
	Sub-total # 5.00						
6.00	Construction of utility room						
	6.10 Earthworks						
	Excavation	cu.m	8				
	Backfill	cu.m	5				
	Gravel bedding	cu.m	2				

ITEM NO.	WORK DESCRIPTION AND SCOPE OF WORK	UNIT	QTY	UNIT COST	MATERIAL COST	LABOR COST	TOTAL COST
	6.20 Concrete works						
	Concrete	cu.m	8				
	Sahara	bags	27				
	Formworks & scaffolding	sq.m	32				
	Rebar w/ tie wires	kgs	673				
	6.30 Masonry works						
	6" CHB w/ rebars	sq.m	49				
	Louver blocks	sq.m	3				
	Plastering	sq.m	84				
	6.40 Doors & Windows:						
	finish complete accessories .80 x 2.10m	set	1				
	2.10m	sq.m	1.89				
	x 0.50m	sets	6				
	6.50 Painting Works:						
	Masonry surface - preparation primer	sq.m	106				
	Masonry surface finish	sq.m	106				
	Steel surface	sq.m	3.5				
	6.60 Plumbing Works:						
	Floor drain 6" X 6" (stainless steel)	pcs	2				
	3" PVC pipe (orange)	pcs	4				
	3" PVC elbow	pcs	8				
	3" x 3" PVC wye	pcs	2				
	PVC solvent 400cc	can	1				
	6.70 Electrical Works:						
	THHN Wire 80.0 mm ²	lm	50				
	THHN Wire 30.0 mm ²	lm	35				
	THHN Wire 22.0 mm ²	lm	40				
	THHN Wire 14.0 mm ²	lm	25				
	THHN Wire 8.0 mm ²	lm	20				
	RSC pipe 2"diam	pc	1				
	PVC Pipe 2" dia. w/ coupling (Orange)	pcs	8				
	PVC Pipe 1" dia. w/ coupling (Orange)	pcs	7				
	PVC Pipe 1/2" dia. w/ coupling (Orange)	pcs	5				
	PVC Long Elbow 2"dia.	pcs	2				
	PVC Long Elbow 1/2"dia.	pcs	36				
	Entrance cap 2"diam	pc	1				
	Secondary Rack w/ 1 spools	set	1				
	RSC Locknut and Bushing 2"diam	pcs	2				
	Rsc Clamp 2" diam	pcs	8				
	Tox and screw 1 1/2"	sets	50				

ITEM NO.	WORK DESCRIPTION AND SCOPE OF WORK	UNIT	QTY	UNIT COST	MATERIAL COST	LABOR COST	TOTAL COST
	Grounding Rod w/ clamp	sets	1				
	Electrical Tape	roll	1				
	Rubber Tape	roll	1				
	PVC Solvent cement 100cc	can	1				
	PVC Pipe 3/4" dia. (Orange)	pcs	2				
	PVC Long Elbow 3/4"dia.	pcs	2				
	Circuit breaker - 200 amp, single phase, w/ NEMA 3R enclosure	set	2				
	Circuit breaker - 125 amp, single phase, w/ NEMA 3R enclosure	set	2				
	Accessory box 6"x14"x4"	set	1				
	Sub-total # 6.00						
7.00	Electrical works						
	7.10 Installation of service entrance :						
	Earthworks :						
	Excavation	cu.m	1.05				
	Backfill w/ compaction	cu.m	0.67				
	Demolition of existing service entrance	lot	1				
	Concrete	cu.m	1				
	Rebars w/ ties	kgs	92.16				
	Formworks	sq.m	10.88				
	Plastering	sq.m	9.6				
	Painting	sq.m	9.6				
	Electrical :						
	THHN Wire 8.0mm	lm	15				
	THHN Wire 3.5mm	lm	20				
	RSC pipe 1"diam	pc	1				
	RSC pipe 1/2"diam	pc	1				
	Entrance cap 1"diam	pc	1				
	Secondary Rack w/ 1 spools	set	1				
	RSC Locknut and Bushing 1"diam	pcs	2				
	RSC Locknut and Bushing 1/2"diam	pc	1				
	RSC Nipple 1"diam	pc	1				
	Rsc Clamp 1" diam	pcs	5				
	Rsc Clamp 1/2" diam	pcs	5				
	Tox and screw 1 1/2"	sets	16				
	Grounding Rod w/ clamp	sets	1				
	Electrical Tape	roll	1				
	Rubber Tape	roll	1				
	PVC Solvent cement 100cc	can	1				
	PVC Pipe 3/4" dia. (Orange)	pcs	2				
	PVC Long Elbow 3/4"dia.	pcs	2				

ITEM NO.	WORK DESCRIPTION AND SCOPE OF WORK	UNIT	QTY	UNIT COST	MATERIAL COST	LABOR COST	TOTAL COST
	Elastomeric sealant	pck	1				

ITEM NO.	WORK DESCRIPTION AND SCOPE OF WORK	UNIT	QTY	UNIT COST	MATERIAL COST	LABOR COST	TOTAL COST
	7.20 Installation of park lamps						
	Pedestal :						
	- Earthworks						
	Excavation	cu.m	0.3				
	Backfill & Compaction	cu.m	0.2				
	- Concrete works						
	Concrete	cu.m	0.2				
	Formworks	sq.m	0.9				
	Rebars w/ tie wires	kgs	15				
	- Finishes						
	Plastering	sq.m	0.6				
	Latex primer w/ surface preparation	sq.m	0.6				
	Painting - latex paint fin.	sq.m	0.6				
				For 1 unit :			
				Consider 13 units :			
	- Electrical						
	Double castle Park lamp w/ 9watts LED bulb	sets	13				
	Single castle wall lamp w/ 9watts LED bulb	sets	36				
	THHN Wire 5.5 mm ² stranded	rolls	4				
	THHN Wire 2.0 mm ² stranded	rolls	2				
	PVC Pipe 3/4" dia. w/ coupling (Orange)	pcs	88				
	PVC Pipe 1/2" dia. w/ coupling (Orange)	pcs	34				
	PVC Long Elbow 3/4" dia.	pcs	28				
	PVC Long Elbow 1/2" dia.	pcs	10				
	PVC Solvent (400 cc)	can	1				
	Junction box 4"x4"	pcs	47				
	LED bulb 9 watts	pcs	47				
	Electrical Tape (big)	pcs	7				
	Rubber Tape	pcs	2				
	NEMA 3R Enclosure Bolt-on type	set	1				
	Circuit Breaker 30AT, Bolt-on type	pc	1				
	Sub-total # 7.00						
8.00	Landscaping works						
	Palawan Cherry	pcs	2				
	Bottle Palm	pcs	3				
	White Kalachuchi	pc	1				
	Foxtail Palm	pcs	3				
	Silver Pandakaki	pcs	80				
	Maki	pcs	1,700				
	Miagos	pcs	80				

ITEM NO.	WORK DESCRIPTION AND SCOPE OF WORK	UNIT	QTY	UNIT COST	MATERIAL COST	LABOR COST	TOTAL COST
	Yellow Iris	pcs	165				

Section IX. Checklist of Technical and Financial Documents

Notes on the Checklist of Technical and Financial Documents

The prescribed documents in the checklist are mandatory to be submitted in the Bid, but shall be subject to the following:

- a. GPPB Resolution No. 09-2020 on the efficient procurement measures during a State of Calamity or other similar issuances that shall allow the use of alternate documents in lieu of the mandated requirements; or
- b. any subsequent GPPB issuances adjusting the documentary requirements after the effectivity of the adoption of the PBDs.

The BAC shall be checking the submitted documents of each Bidder against this checklist to ascertain if they are all present, using a non-discretionary “pass/fail” criterion pursuant to Section 30 of the 2016 revised IRR of RA No. 9184.

Checklist of Technical and Financial Documents

I. TECHNICAL COMPONENT ENVELOPE

Class “A” Documents

Legal Documents

- (a) Valid PhilGEPS Registration Certificate (Platinum Membership) (all pages);
and
- (b) Registration certificate from Securities and Exchange Commission (SEC), Department of Trade and Industry (DTI) for sole proprietorship, or Cooperative Development Authority (CDA) for cooperatives or its equivalent document;
and
- (c) Mayor’s or Business permit issued by the city or municipality where the principal place of business of the prospective bidder is located, or the equivalent document for Exclusive Economic Zones or Areas;
and
- (e) Tax clearance per E.O. No. 398, s. 2005, as finally reviewed and approved by the Bureau of Internal Revenue (BIR).

Technical Documents

- (f) Statement of the prospective bidder of all its ongoing government and private contracts, including contracts awarded but not yet started, if any, whether similar or not similar in nature and complexity to the contract to be bid (*please see attached prescribed forms required by the QC – BAC for Infrastructure and Consultancy*); **and**
- (g) Statement of the bidder’s Single Largest Completed Contract (SLCC) similar to the contract to be bid, except under conditions provided under the rules with an attached Notice of Award, Notice to Proceed, Contract and Certificate of Acceptance (*please see attached prescribed form required by the QC – BAC for Infrastructure and Consultancy*); **and**
- (h) Philippine Contractors Accreditation Board (PCAB) License;
or
Special PCAB License in case of Joint Ventures;
and registration for the type and cost of the contract to be bid; **and**
- (i) Original copy of Bid Security. If in the form of a Surety Bond, submit also a certification issued by the Insurance Commission;
or
Original copy of Notarized Bid Securing Declaration; **and**
- (j) Project Requirements, which shall include the following:
 - a. Organizational chart for the contract to be bid;
 - b. List of contractor’s key personnel (*e.g.*, Project Manager, Project Engineers, Materials Engineers, and Foremen), to be assigned to the contract to be bid, with their complete qualification and experience data (*please see attached prescribed form required by the QC – BAC for Infrastructure and Consultancy*);
 - c. List of contractor’s major equipment units, which are owned, leased, and/or under purchase agreements, supported by proof of ownership or certification of availability of equipment from the equipment

lessor/vendor for the duration of the project, as the case may be (*please see attached prescribed form required by the QC – BAC for Infrastructure and Consultancy*); **and**

- (k) Original duly signed Omnibus Sworn Statement (OSS); **and** if applicable, Original Notarized Secretary's Certificate in case of a corporation, partnership, or cooperative; or Original Special Power of Attorney of all members of the joint venture giving full power and authority to its officer to sign the OSS and do acts to represent the Bidder.

Additional Technical Requirements:

- Certificate of Site Inspection or Affidavit of Site Inspection as part of Omnibus Sworn Statement
- Affidavit of Undertaking for Key Personnel and Equipment (*please see attached prescribed form required by the QC – BAC for Infrastructure and Consultancy*)
- Equipment Utilization Schedule
- Manpower Schedule
- Construction Schedule and S-Curve
- PERT-CMP
- Construction Methods

Financial Documents

- (l) The prospective bidder's audited financial statements, showing, among others, the prospective bidder's total and current assets and liabilities, stamped "received" by the BIR or its duly accredited and authorized institutions, for the preceding calendar year which should not be earlier than two (2) years from the date of bid submission; **and**
- (m) The prospective bidder's computation of Net Financial Contracting Capacity (NFCC) (*please see attached prescribed form required by the QC – BAC for Infrastructure and Consultancy*).

Class "B" Documents

- (n) If applicable, duly signed joint venture agreement (JVA) in accordance with RA No. 4566 and its IRR in case the joint venture is already in existence; **or** duly notarized statements from all the potential joint venture partners stating that they will enter into and abide by the provisions of the JVA in the instance that the bid is successful.

II. FINANCIAL COMPONENT ENVELOPE

- (o) Original of duly signed and accomplished Financial Bid Form; **and**

Other documentary requirements under RA No. 9184

- (p) Original of duly signed Bid Prices in the Bill of Quantities; **and**
- (q) Duly accomplished Detailed Estimates Form, including a summary sheet indicating the unit prices of construction materials, labor rates, and equipment rentals used in coming up with the Bid; **and**
- (r) Cash Flow by Quarter.

Bid Form for the Procurement of Infrastructure Projects
[shall be submitted with the Bid]

BID FORM

Date : _____
Project Identification No. : _____

To: *[name and address of Procuring Entity]*

Having examined the Philippine Bidding Documents (PBDs) including the Supplemental or Bid Bulletin Numbers *[insert numbers]*, the receipt of which is hereby duly acknowledged, we, the undersigned, declare that:

- a. We have no reservation to the PBDs, including the Supplemental or Bid Bulletins, for the Procurement Project: *[insert name of contract]*;
- b. We offer to execute the Works for this Contract in accordance with the PBDs;
- c. The total price of our Bid in words and figures, excluding any discounts offered below is: *[insert information]*;
- d. The discounts offered and the methodology for their application are: *[insert information]*;
- e. The total bid price includes the cost of all taxes, such as, but not limited to: *[specify the applicable taxes, e.g. (i) value added tax (VAT), (ii) income tax, (iii) local taxes, and (iv) other fiscal levies and duties]*, which are itemized herein and reflected in the detailed estimates,
- f. Our Bid shall be valid within the a period stated in the PBDs, and it shall remain binding upon us at any time before the expiration of that period;
- g. If our Bid is accepted, we commit to obtain a Performance Security in the amount of *[insert percentage amount]* percent of the Contract Price for the due performance of the Contract, or a Performance Securing Declaration in lieu of the the allowable forms of Performance Security, subject to the terms and conditions of issued GPPB guidelines¹ for this purpose;
- h. We are not participating, as Bidders, in more than one Bid in this bidding process, other than alternative offers in accordance with the Bidding Documents;
- i. We understand that this Bid, together with your written acceptance thereof included in your notification of award, shall constitute a binding contract between us, until a formal Contract is prepared and executed; and
- j. We understand that you are not bound to accept the Lowest Calculated Bid or any other Bid that you may receive.

¹ currently based on GPPB Resolution No. 09-2020

- k. We likewise certify/confirm that the undersigned, is the duly authorized representative of the bidder, and granted full power and authority to do, execute and perform any and all acts necessary to participate, submit the bid, and to sign and execute the ensuing contract for the [Name of Project] of the [Name of the Procuring Entity].
- l. We acknowledge that failure to sign each and every page of this Bid Form, including the Bill of Quantities, shall be a ground for the rejection of our bid.

Name: _____

Legal Capacity: _____

Signature: _____

Duly authorized to sign the Bid for and behalf of: _____

Date: _____

Bid Securing Declaration Form

[shall be submitted with the Bid if bidder opts to provide this form of bid security]

REPUBLIC OF THE PHILIPPINES)
CITY OF _____) S.S.

BID SECURING DECLARATION **Project Identification No.: *[Insert number]***

To: *[Insert name and address of the Procuring Entity]*

I/We, the undersigned, declare that:

1. I/We understand that, according to your conditions, bids must be supported by a Bid Security, which may be in the form of a Bid Securing Declaration.
2. I/We accept that: (a) I/we will be automatically disqualified from bidding for any procurement contract with any procuring entity for a period of two (2) years upon receipt of your Blacklisting Order; and, (b) I/we will pay the applicable fine provided under Section 6 of the Guidelines on the Use of Bid Securing Declaration, within fifteen (15) days from receipt of the written demand by the procuring entity for the commission of acts resulting to the enforcement of the bid securing declaration under Sections 23.1(b), 34.2, 40.1 and 69.1, except 69.1(f), of the IRR of RA No. 9184; without prejudice to other legal action the government may undertake.
3. I/We understand that this Bid Securing Declaration shall cease to be valid on the following circumstances:
 - a. Upon expiration of the bid validity period, or any extension thereof pursuant to your request;
 - b. I am/we are declared ineligible or post-disqualified upon receipt of your notice to such effect, and (i) I/we failed to timely file a request for reconsideration or (ii) I/we filed a waiver to avail of said right; and
 - c. I am/we are declared the bidder with the Lowest Calculated Responsive Bid, and I/we have furnished the performance security and signed the Contract.

IN WITNESS WHEREOF, I/We have hereunto set my/our hand/s this ____ day of *[month]* *[year]* at *[place of execution]*.

*[Insert NAME OF BIDDER OR ITS AUTHORIZED
REPRESENTATIVE]
[Insert signatory's legal capacity]
Affiant*

[Jurat]

[Format shall be based on the latest Rules on Notarial Practice]

Omnibus Sworn Statement (Revised)

[shall be submitted with the Bid]

REPUBLIC OF THE PHILIPPINES)
CITY/MUNICIPALITY OF _____) S.S.

AFFIDAVIT

I, [Name of Affiant], of legal age, [Civil Status], [Nationality], and residing at [Address of Affiant], after having been duly sworn in accordance with law, do hereby depose and state that:

1. *[Select one, delete the other:]*

[If a sole proprietorship:] I am the sole proprietor or authorized representative of [Name of Bidder] with office address at [address of Bidder];

[If a partnership, corporation, cooperative, or joint venture:] I am the duly authorized and designated representative of [Name of Bidder] with office address at [address of Bidder];

2. *[Select one, delete the other:]*

[If a sole proprietorship:] As the owner and sole proprietor, or authorized representative of [Name of Bidder], I have full power and authority to do, execute and perform any and all acts necessary to participate, submit the bid, and to sign and execute the ensuing contract for [Name of the Project] of the [Name of the Procuring Entity], as shown in the attached duly notarized Special Power of Attorney;

[If a partnership, corporation, cooperative, or joint venture:] I am granted full power and authority to do, execute and perform any and all acts necessary to participate, submit the bid, and to sign and execute the ensuing contract for [Name of the Project] of the [Name of the Procuring Entity], as shown in the attached [state title of attached document showing proof of authorization (e.g., duly notarized Secretary's Certificate, Board/Partnership Resolution, or Special Power of Attorney, whichever is applicable)];

3. [Name of Bidder] is not "blacklisted" or barred from bidding by the Government of the Philippines or any of its agencies, offices, corporations, or Local Government Units, foreign government/foreign or international financing institution whose blacklisting rules have been recognized by the Government Procurement Policy Board, **by itself or by relation, membership, association, affiliation, or controlling interest with another blacklisted person or entity as defined and provided for in the Uniform Guidelines on Blacklisting;**

4. Each of the documents submitted in satisfaction of the bidding requirements is an authentic copy of the original, complete, and all statements and information provided therein are true and correct;

5. [Name of Bidder] is authorizing the Head of the Procuring Entity or its duly authorized representative(s) to verify all the documents submitted;

6. *[Select one, delete the rest:]*

[If a sole proprietorship:] The owner or sole proprietor is not related to the Head of the Procuring Entity, members of the Bids and Awards Committee (BAC), the Technical Working Group, and the BAC Secretariat, the head of the Project Management Office or the end-user unit, and the project consultants by consanguinity or affinity up to the third civil degree;

[If a partnership or cooperative:] None of the officers and members of [Name of Bidder] is related to the Head of the Procuring Entity, members of the Bids and Awards Committee (BAC), the Technical Working Group, and the BAC Secretariat, the head of the Project

Management Office or the end-user unit, and the project consultants by consanguinity or affinity up to the third civil degree;

[If a corporation or joint venture:] None of the officers, directors, and controlling stockholders of *[Name of Bidder]* is related to the Head of the Procuring Entity, members of the Bids and Awards Committee (BAC), the Technical Working Group, and the BAC Secretariat, the head of the Project Management Office or the end-user unit, and the project consultants by consanguinity or affinity up to the third civil degree;

7. *[Name of Bidder]* complies with existing labor laws and standards; and
8. *[Name of Bidder]* is aware of and has undertaken the responsibilities as a Bidder in compliance with the Philippine Bidding Documents, which includes:
 - a. Carefully examining all of the Bidding Documents;
 - b. Acknowledging all conditions, local or otherwise, affecting the implementation of the Contract;
 - c. Making an estimate of the facilities available and needed for the contract to be bid, if any; and
 - d. Inquiring or securing Supplemental/Bid Bulletin(s) issued for the *[Name of the Project]*.
9. *[Name of Bidder]* did not give or pay directly or indirectly, any commission, amount, fee, or any form of consideration, pecuniary or otherwise, to any person or official, personnel or representative of the government in relation to any procurement project or activity.
10. **In case advance payment was made or given, failure to perform or deliver any of the obligations and undertakings in the contract shall be sufficient grounds to constitute criminal liability for Swindling (Estafa) or the commission of fraud with unfaithfulness or abuse of confidence through misappropriating or converting any payment received by a person or entity under an obligation involving the duty to deliver certain goods or services, to the prejudice of the public and the government of the Philippines pursuant to Article 315 of Act No. 3815 s. 1930, as amended, or the Revised Penal Code.**
11. We pledge that the project will be completed in accordance and congruency with the approved plans and programs.

IN WITNESS WHEREOF, I have hereunto set my hand this ___ day of _____ 20__ at _____, Philippines.

[Insert NAME OF BIDDER OR ITS AUTHORIZED REPRESENTATIVE]

[Insert signatory's legal capacity]

Affiant

[Jurat]

[Format shall be based on the latest Rules on Notarial Practice]

**Contract Agreement Form for the
Procurement of Infrastructure Projects (Revised)**

*[not required to be submitted with the Bid, but it shall be submitted within ten (10) days after
receiving the Notice of Award]*

CONTRACT AGREEMENT

THIS AGREEMENT, made this *[insert date]* day of *[insert month]*, *[insert year]* between *[name and address of PROCURING ENTITY]* (hereinafter called the "Entity") and *[name and address of Contractor]* (hereinafter called the "Contractor").

WHEREAS, the Entity is desirous that the Contractor execute *[name and identification number of contract]* (hereinafter called "the Works") and the Entity has accepted the Bid for *[contract price in words and figures in specified currency]* by the Contractor for the execution and completion of such Works and the remedying of any defects therein.

NOW THIS AGREEMENT WITNESSETH AS FOLLOWS:

1. In this Agreement, words and expressions shall have the same meanings as are respectively assigned to them in the Conditions of Contract hereinafter referred to.
2. The following documents as required by the 2016 revised Implementing Rules and Regulations of Republic Act No. 9184 shall be deemed to form and be read and construed as part of this Agreement, viz.:
 - a. Philippine Bidding Documents (PBDs);
 - i. Drawings/Plans;
 - ii. Specifications;
 - iii. Bill of Quantities;
 - iv. General and Special Conditions of Contract;
 - v. Supplemental or Bid Bulletins, if any;
 - b. Winning bidder's bid, including the Eligibility requirements, Technical and Financial Proposals, and all other documents or statements submitted;

Bid form, including all the documents/statements contained in the Bidder's bidding envelopes, as annexes, and all other documents submitted (e.g., Bidder's response to request for clarifications on the bid), including corrections to the bid, if any, resulting from the Procuring Entity's bid evaluation;
 - c. Performance Security;
 - d. Notice of Award of Contract and the Bidder's conforme thereto; and
 - e. Other contract documents that may be required by existing laws and/or the Procuring Entity concerned in the PBDs. **Winning bidder agrees that additional contract documents or information prescribed by the GPPB that are subsequently required for submission after the contract execution, such as the Notice to Proceed, Variation Orders, and Warranty Security, shall likewise form part of the Contract.**
3. In consideration for the sum of *[total contract price in words and figures]* or such other sums as may be ascertained, *[Named of the bidder]* agrees to *[state the object of the contract]* in accordance with his/her/its Bid.

4. The *[Name of the procuring entity]* agrees to pay the above-mentioned sum in accordance with the terms of the Bidding.

IN WITNESS whereof the parties thereto have caused this Agreement to be executed the day and year first before written.

[Insert Name and Signature] [Insert Name and Signature]

[Insert Signatory's Legal Capacity] [Insert Signatory's Legal Capacity]

for: for:

[Insert Procuring Entity] [Insert Name of Supplier]

Acknowledgment

[Format shall be based on the latest Rules on Notarial Practice]

Performance Securing Declaration (Revised)

[if used as an alternative performance security but it is not required to be submitted with the Bid, as it shall be submitted within ten (10) days after receiving the Notice of Award]

REPUBLIC OF THE PHILIPPINES)
CITY OF _____) S.S.

PERFORMANCE SECURING DECLARATION

Invitation to Bid: [Insert Reference Number indicated in the Bidding Documents] To:
[Insert name and address of the Procuring Entity]

I/We, the undersigned, declare that:

1. I/We understand that, according to your conditions, to guarantee the faithful performance by the supplier/distributor/manufacturee/contractor/consultant of its obligations under the Contract, I/we shall submit a Performance Securing Declaration within a maximum period of ten (10) calendar days from the receipt of the Notice of Award prior to the signing of the Contract.
2. I/We accept that: I/we will be automatically disqualified from bidding for any procurement contract with any procuring entity for a period of one (1) year for the first offense, or two (2) years **for the second offense**, upon receipt of your Blacklisting Order if I/We have violated my/our obligations under the Contract;
3. I/We understand that this Performance Securing Declaration shall cease to be valid upon:
 - a. issuance by the Procuring Entity of the Certificate of Final Acceptance, subject to the following conditions:
 - i. Procuring Entity has no claims filed against the contract awardee;
 - ii. It has no claims for labor and materials filed against the contractor; and
 - iii. Other terms of the contract; or
 - b. replacement by the winning bidder of the submitted PSD with a performance security in any of the prescribed forms under Section 39.2 of the 2016 revised IRR of RA No. 9184 as required by the end-user.

IN WITNESS WHEREOF, I/We have hereunto set my/our hand/s this ____ day of [month] [year] at [place of execution].

*[Insert NAME OF BIDDER OR ITS
AUTHORIZED REPRESENTATIVE]
[Insert signatory's legal capacity]
Affiant*

[Jurat]

[Format shall be based on the latest Rules on Notarial Practice]

LIST OF ALL ON-GOING GOVERNMENT AND PRIVATE CONTRACTS

NAME OF CONTRACTOR: _____

PROJECT TITLE (Name of the Contract) & EXACT PROJECT LOCATION	DATE OF CONTRACT	CONTRACT DURATION	PROJECT OWNER & POSTAL ADDRESS	NATURE OF WORK	CONTRACTOR'S ROLE (SOLE CONTRACTOR, SUBCONTRACTOR, PARTNER IN A JV) and PERCENTAGE OF PARTICIPATION	TOTAL CONTRACT VALUE AT AWARD	DATE OF COMPLETION or ESTIMATED COMPLETION TIME	TOTAL CONTRACT VALUE AT COMPLETION IF APPLICABLE	PERCENTAGE		VALUE OF OUTSTANDING WORKS (IN PHP)
									ACTUAL ACCOMPLISHMENT	PLANNED ACCOMPLISHMENT	
									TOTAL AMOUNT (Php) OF OUTSTANDING WORKS		

PHOTOCOPY ADDITIONAL FORMS, IF NECESSARY

LIST OF ALL AWARDED BUT NOT YET STARTED GOVERNMENT AND PRIVATE CONTRACTS OF THE BIDDER

NAME OF CONTRACTOR: _____

PROJECT TITLE: _____

PROJECT TITLE & EXACT LOCATION	MAJOR SCOPE OF WORKS & DATE STARTED	NAME AND ADDRESS OF PROJECT OWNER	CONTRACT PRICE (PHP) AS AWARDED	DATE OF SCHEDULED COMPLETION	ROLE OF BIDDER IN THE <u>CONTRACT</u> <u>SOLE CONTRACTOR / SUB-CONTRACTOR/PARTNER IN A</u>
	TOTAL AMOUNT OF CONTRACT (Php)				

SINGLE LARGEST COMPLETED CONTRACT SIMILAR TO THE CONTRACT TO BE BID

NAME OF CONTRACTOR: _____

PROJECT TITLE: _____

PROJECT TITLE (Name of the Contract) & EXACT PROJECT LOCATION	DATE OF CONTRACT	CONTRACT DURATION	PROJECT OWNER & POSTAL ADDRESS	NATURE OF WORK	CONTRACTOR'S ROLE (SOLE CONTRACTOR, SUBCONTRACTOR, PARTNER IN A JV) and PERCENTAGE OF PARTICIPATION	TOTAL CONTRACT VALUE AT AWARD	DATE OF COMPLETION or ESTIMATED COMPLETION TIME	TOTAL CONTRACT VALUE AT COMPLETION IF APPLICABLE

PHOTOCOPY ADDITIONAL FORMS, IF NECESSARY

Page _____ of _____

LIST OF MAJOR EQUIPMENT TO BE USED FOR THE PROJECT

NAME OF CONTRACTOR: _____

PROJECT TITLE: _____

TYPE	DESCRIPTION / CAPACITY	SERIAL NO.	YEAR ACQUIRED	PRESENT LOCATION (SPECIFIC ADDRESS)	STATUS OF AVAILABILITY (OWNED/LEASED)

A. LIST OF KEY CONSTRUCTION PERSONNEL TO BE ASSIGNED TO THE PROJECT

NAME OF CONTRACTOR: _____

PROJECT TITLE: _____

NAME	POSITION	AGE	EDUCATIONAL ATTAINMENT	TYPE OF CONSTRUCTION EXPERIENCE	NO.OF YEARS WITH THE CONTRACTOR	PROFESSION	PRC NO.

COMPUTATION OF NET FINANCIAL CONTRACTING CAPACITY (NFCC)

NAME OF BIDDER: _____

CURRENT ASSETS*		PHP	_____
(LESS) CURRENT LIABILITIES*	(LESS)	PHP	_____
NETWORTH		PHP	_____
NETWORTH x 15	x 15	PHP	_____
(LESS) VALUE OF ALL OUTSTANDING ON-GOING CONTRACTS**	(LESS)	PHP	_____
(LESS) VALUE OF ALL AWARDED BUT NOT YET STARTED CONTRACTS AS OF DATE**	(LESS)	PHP	_____
NET FINANCIAL CONTRACTING CAPACITY		PHP	_____

NOTES: * CURRENT ASSETS AND LIABILITIES BASED ON AUDITED FINANCIAL STATEMENT FOR THE PRECEDING CALENDAR YEAR SUBMITTED TO B.I.R.

** BASED ON LIST OF ON-GOING AND AWARDED BUT NOT YET STARTED CONTRACTS SUBMITTED

REPUBLIC OF THE PHILIPPINES)

_____) S.S.

AFFIDAVIT OF UNDERTAKING

I, _____ of legal age, Filipino, _____ [OFFICER OR REPRESENTATIVE]

with office address at _____ after having been duly sworn to in accordance with law, hereby voluntary depose and state:

That I am duly authorized representative of the [Name of Bidder] to execute this undertaking as evidenced by Secretary's Certificate and Board Resolution.

That [Name of Bidder] bidding for the (Name of Project)

That relative to the aforementioned Project, the [Name of Bidder] hereby undertake that the equipment to be use and the key personnel to be assign shall exclusively be used and will only perform to the said project until its completion.

That I am executing this affidavit to attest to the truth of the foregoing and in compliance with the submission of the technical requirements for the public bidding of the said project.

IN WITNESS HEREOF, I have hereunto signed my name below this _____ day of _____ at _____.

AFFIANT FURTHER SAYETH NAUGHT.

Affiant

SUBSCRIBED AND SWORN TO BEFORE ME this _____ day of _____
in _____

affiant exhibiting to me his/her _____ issued at _____
on _____

Doc. No. ;
Page No. ;
Book No. ;
Series of 2020

Notary Public

